

# Health & Safety Manual

## Alberici Constructors, Inc.

February 2026





## **SAFETY MISSION, VALUE STATEMENT, AND MANAGEMENT COMMITMENT**

Alberici Constructors, Inc. considers the health and safety of our employees, trade partners, clients, and the general public to be as important to our success as quality, schedule, production, and cost control.

We value life above all else. To accomplish this, we have an organized and effective safety program at each project location that aligns with our corporate values and our client expectations.

Our management team is committed to continuous improvement of measures aimed at ensuring the highest degree of safety in our operations through our cornerstone policy, Built In Safety.

We believe incidents can be prevented through planning, training, detailed project execution strategies, and cooperative efforts by all parties involved. We believe collaboration is essential and are proactive in our efforts to prevent injuries, illnesses, property damage, and damage to the environment.

Our programs exceed minimum requirements of measures as mandated by local, state, and federal legislation, and we reference consensus standards when practicable to strengthen our program.

We expect all persons associated with our organizations to comply with the intent of this Safety Policy Statement as Alberici continually strives toward industry-leading success in safety and health management.

A handwritten signature in blue ink, appearing to read 'Jose Garcia'.

Jose Garcia  
President – Alberici Constructors



## TABLE OF CONTENTS

<b>Section I: Administrative .....</b>	<b>1</b>
Built In Safety.....	2
Built In Safety Commitment Workshop.....	4
Communication.....	5
Activity Hazard Assessment and SafeCards.....	6
Training Programs.....	7
Employee Responsibilities.....	8
Subcontractor Responsibilities .....	9
Disciplinary Action Program .....	10
Recordkeeping .....	13
OSHA Inspection Guidelines.....	14
Incident Management and Investigation .....	17
<b>Section II: General Safety .....</b>	<b>18</b>
Asbestos Exposure Control.....	19
Bloodborne Pathogens Exposure Control Program.....	21
Hepatitis B Vaccination, Post-Exposure Evaluation, and Follow-Up .....	26
Compressed Gas Cylinders.....	29
Confined Space .....	31
Cranes and Rigging.....	43
Electrical.....	49
Excavation and Trenching .....	58
Fall Management Program.....	64
Fire Protection.....	69
Emergency First Aid.....	72
Floor and Wall Openings.....	74
Hand and Portable Powered Tools .....	76
Hazard Communication.....	82
Hearing Conservation Program .....	85
Heat Illness Awareness and Prevention .....	88
Helicopter Safety Procedure .....	96
Housekeeping .....	98
Lead in Construction .....	99
Lockout Procedure.....	102
Machines and Machine Guarding .....	107
Mobile Elevated Work Platforms (MEWP, Aerial Lifts).....	111
Powered Industrial Trucks.....	118
Personal Protective Equipment (PPE) .....	120
Process Safety Management .....	129



Public and Utility Protection ..... 131

Respiratory Protection Program ..... 134

Scaffold Procedures..... 141

Silica Exposure Plan ..... 148

Stairways and Ladders ..... 152

Steel Erection..... 158

Stretch and Flex Program .....161

Welding and Burning .....163

**Section III: Environmental Safety..... 172**

Environmental Awareness.....173

Spill Containment Plan .....175

**Appendix: Forms..... 176**



SECTION I

# Administrative





## BUILT IN SAFETY

All of us at Alberici share a bold commitment to protecting the well-being of our employees, clients, partners, communities, and the environment.

### Award-Winning Safety Performance

At Alberici, safety is a part of who we are. Our goal for safety is simple: execute our work in the safest means possible to achieve zero incidents on all our projects. While our zero-incident goal is ambitious, it is also achievable. We believe that all injuries and occupational illnesses can be prevented. We never waver in our commitment to ensure everyone goes home injury-free every day.

This shared commitment has delivered measurable results across our project portfolio.

### Safety Culture

Our safety culture is underpinned by our award-winning program: **Built In Safety**. This program goes beyond standard procedures to instill safety into our planning, mindset, and every action we take onsite.

### Built In Safety: A Mindset, Not a Mandate

Built In Safety is not simply a program or checklist—it is an embedded mindset. It defines how we plan, act, and lead. Safety is intrinsic to our identity and unites us in a common purpose: to protect the well-being of our employees, trade partners, clients, communities, and the environment.





## GUIDING PRINCIPLES



### PLAN & ASSESS

We invest in tools and frameworks for effective planning and risk management to integrate safety into everything we do.



### ENGAGE & COMMUNICATE

We empower active participation through access, awareness, orientation, training, prevention, reporting, and recognition.



### COLLABORATE & INTEGRATE

We invest in tools and frameworks for effective planning and risk management to integrate safety into everything we do.



### LEARN & IMPROVE

We innovate our processes and systems to enhance safeguards and guide meaningful change.



### LEAD & OWN

We champion a culture of responsibility, demonstrating visible leadership while owning outcomes of safety.

## Mindset

Safety at Alberici begins long before we ever step onto the jobsite. It is how we think, how we prepare, and how we engage with one another. It is a shared understanding that every action we take has an impact. This mindset drives a culture where safety is not the responsibility of a few—it's the responsibility of all.

## Commitment

We empower our people to be bold and courageous in protecting themselves and each other. Every individual on an Alberici project—regardless of title or tenure—is a champion for safety without hesitation. Whether it's raising a concern, stopping work, or coaching a peer, we trust our teams to act decisively and with purpose. This commitment is evident across all levels of our organization and manifests in the safe, productive environments we cultivate every day.

## Resources

Our safety culture is reinforced by robust investments in people, systems, and innovation. From best-in-class training and equipment to leading safety technologies and analytics, we provide the tools necessary to anticipate and mitigate risk. Continuous improvement is part of our DNA. We actively seek feedback, assess outcomes, and refine our processes so that every project is safer than the last.



## BUILT IN SAFETY COMMITMENT WORKSHOP

The **Built In Safety Commitment Workshop** brings leaders and teams together to define what safety truly means in their organization—and how it shows up in everyday decisions and behaviors. Through guided discussion, real-world scenarios, and collaborative reflection, participants clarify shared expectations, align safety with operational goals, and establish a clear, personal commitment to doing work the right way. The workshop turns safety from a set of rules into a lived value, creating ownership, accountability, and a foundation for sustained cultural change.



**Name:**

---

**Why I work safely:**

---

---

---

---

---

**My commitment to Built in Safety:**

---

---

---

---







## COMMUNICATION

### Intranet Website

Alberici's intranet, theCommons, is a communication tool that contains safety documents, forms, logs, shared learning documents, and other safety resources.

### New Hire Orientation

All Alberici employees are required to participate in a comprehensive orientation program upon hire and prior to performing any site fieldwork. An introduction to the Built In Safety safety program is integral to comprehensive new hire orientation. The basic information presented in orientation is reinforced with more detailed, site-specific information when the employee arrives at a project site.



## ACTIVITY HAZARD ASSESSMENT AND SAFECARDS

This section outlines two foundational safety processes—**Activity Hazard Assessment (AHA)** and the **SafeCard (Daily Hazard Assessment)**—used to identify, evaluate, and control workplace hazards at Alberici project sites. These tools are required on all projects and apply to employees, subcontractors, and other covered parties.

The **AHA SOP** defines the process for pre-task hazard identification and control planning at the definable feature of work level. AHAs are developed by qualified project personnel and reviewed by supervisors, safety, and management depending on risk level. Each AHA breaks down the task into steps, identifies potential hazards, and documents required control measures using the hierarchy of controls. AHAs are integrated into the Site-Specific Safety Plan and are reviewed with crews before work begins and updated as conditions change.

The **SafeCard SOP** establishes the process for daily hazard assessment and conversation. SafeCards are completed by supervisors or foremen before work begins, with active crew participation. They incorporate lessons learned, identify site-specific conditions, and reference supporting documents like AHAs, SOPs, permits, and Safety Data Sheets (SDSs). The SafeCard is reviewed a minimum of three times daily as conditions evolve, per the “Rule of Three.” Supervisors lead crew conversations to ensure understanding of risks and responsibilities, while safety personnel verify completion and coach teams on effective use.

Together, these SOPs ensure hazards are proactively addressed at both the task planning and daily execution levels, promoting ownership, dialogue, and continuous improvement in hazard control.

Click the link to download the [Activity Hazard Assessment SOP](#).

Click the link to download the [SafeCard \(Daily Hazard Assessment\) SOP](#).



## TRAINING PROGRAMS

Alberici is committed to providing quality training on relevant topics. Alberici is proactive in our approach to develop employee capabilities to eliminate or reduce risks before incidents occur.

Examples of training include:

- » All components available in Alberici's internal Alberici Career Education program
- » OSHA 10-Hour Construction Outreach
- » OSHA 30-Hour Construction Outreach
- » First aid and CPR
- » Qualified riggers and signalpersons
- » Equipment operators (counterbalanced lift trucks, rough terrain lift trucks, aerial work platforms, and aerial boom lifts)

Many of our craft workers are trained in their Joint Apprenticeship Training Centers (JATC), and their training should be documented and validated at the project level.

### **Equipment Training and Certification – Operator Skills Test**

Projects will need to verify skill levels and proper operation of equipment such as cranes, both conventional and hydraulic, as well as rough terrain forklifts.

Certification procedures and skills tests are included in the equipment-specific sections of this safety manual.

Skills tests are short practical exams to verify proper operation, ability to use load charts, and demonstration of safe operation of the equipment before being put in a work environment where a crew's safety could be jeopardized.



## EMPLOYEE RESPONSIBILITIES

Every employee has safety and health authorities and responsibilities. Some common expectations include:

- » Arrive at work fit for duty
- » Participate in SafeCard meeting and Stretch and Flex
- » Review AHAs applicable to work assignment
- » Participate in behavior-based safety observations and recognition programs
- » Complete and maintain assigned safety training, certifications, designations, and qualifications (licenses, registrations etc.)
- » Report incidents immediately to supervisors
- » Where applicable, participate in injury investigation, including “5 whys”/root cause
- » Always observe all project site safety requirements in the field
- » Always use controls measure devices and personal protective equipment as designed and required/recommended for tasks
- » Stop work if an unmitigated hazard (or potential hazard) is identified or suspected
- » Lead by example, and proactively motivate others to work safely



## SUBCONTRACTOR RESPONSIBILITIES

All Alberici subcontractors are responsible for developing and implementing their own safety programs, ensuring the safety and health of their employees, others working on site, and the general public.

All Alberici subcontractors must comply with the following:

- » Follow all safety requirements identified in contracts and other agreements.
- » Submit a copy of their company's safety manual, including a copy of their hazard communication program.
- » Furnish a certificate of insurance.
- » Ensure development of policies, programs, and training to meet the requirements of the Federal Occupational Safety and Health Act, as well as local and state regulations.
- » Conduct a job safety analysis, considering all safety and health factors throughout the various stages of the job. Submit a copy prior to the start of work.
- » Develop and maintain emergency preparedness procedures specifically for the project. These procedures will include, but are not limited to, fire, weather, and first aid. Submit a copy prior to the start of work.
- » Perform a site-specific safety orientation for all newly hired employees. This indoctrination is in addition to the Alberici safety awareness orientation program, site-specific safety rules and regulations, specific job-related hazards, and the emergency preparedness procedures developed for the project.
- » At a minimum, conduct a written site safety inspection report each week. The report will identify specific work areas, address any unsafe conditions and/or practices, and list corrective measures taken.
- » Perform weekly safety training sessions and safety meetings for all employees. These training sessions shall include, but are not limited to, a prepared safety topic that is relevant to the work being conducted and discussions pertaining to the hazards of the project site, accidents/incidents, and safety violations. A list of all employees attending the training sessions (sign-up sheet) is required.
- » All safety incidents, injuries, and/or property damage, no matter how slight, must be reported immediately, and the investigation and abatement shall be initiated within an agreed-upon time, not more than 24 hours. Investigation reports must contain a detailed description of the accident or incident, the cause of the accident or incident, an explanation of the injuries and preventive measures taken to avoid recurrence, as well as photos that re-create the incident and clarify points in the investigation.
- » Conduct a weekly safety performance report.
- » All Alberici subcontractors must determine whether any additional requirements are necessary to cover all the trade-specific hazards encountered. Contract language will take precedence, and the most stringent policy must be followed.



## DISCIPLINARY ACTION PROGRAM

### Purpose

Everyone has an obligation to work by and obey all rules, programs, and policies established by Alberici. Actions that violate Alberici's safe working policies will be handled per the below program.

Examples provided are not intended to be all-inclusive.

### Class 1 Category

Class 1A is a violation that puts a person or persons in immediate and extreme danger through disregard of safety practices and the safety program. Examples include but are not limited to threatening a co-worker; fighting; willfully ignoring zero-tolerance safety rules; or knowingly creating, participating in, directing, or allowing an action that creates a high potential for death or serious injury.

The first substantiated Class 1A violation for an employee may result in termination from all Alberici projects for a period of up to one (1) year.

Class 1B is a violation of Alberici safety rules that puts the employee or others at risk. Examples include but are not limited to violating the zero-tolerance policies.

The first substantiated Class 1B violation shall be a suspension from work on Alberici projects for three (3) consecutive scheduled workdays, unless the violation occurs because of provable miscommunication, misdirection, confusion, lack of training, or a lack of understanding that puts employees into a dangerous or threatening circumstance.

After the three (3)-day suspension and before the employee begins work, the employee shall at a minimum complete a reorientation of the project safety rules that led to the discipline being issued.

The second substantiated Class 1B violation within the same 12-month period will result in termination of employment from all Alberici projects for a period of not less than one (1) year.

### Zero Tolerance Class 1

Some actions can have more severe consequences than others. A violation of the below standards could result in serious injury or death. Therefore, these violations are disciplined in a zero-tolerance manner. A violation in this group carries, at a minimum, a Class 1B three (3)-day unpaid suspension. No other warnings or corrections will be given.

- » Violating fall protection requirements
- » Violating confined space program
- » Violating the trenching and excavating requirements
- » Violating the lock-out/tag-out program
- » Overloading a piece of equipment

*Class 1 violations will be reviewed by an Incident Review Committee consisting of trade leadership, safety, project team, and executive management. Determinations of the Incident Review Committee are final.*



## Class 2 Category

A Class 2 violation is one that would not cause death, serious injury, or major property damage. Examples may not be all-inclusive; Alberici will have the sole discretion in making the determination.

The first substantiated Class 2 violation for an employee will result in a written warning.

The second substantiated Class 2 violation for an employee within a 12-month period will result in a suspension from work on all Alberici projects for three (3) consecutive scheduled workdays. Upon returning to work after the three-day suspension the employee shall at a minimum complete a reorientation of the project safety rules that led to the discipline being issued.

The third substantiated Class 2 violation for an employee within the same 12-month period will result in termination of employment from all Alberici projects for a period of not less than one (1) year.

Multiple violations in a 12-month period:

- » Class 1B + Class 1B = termination of employment from all Alberici projects for a period of not less than one (1) year
- » Class 1B + Class 2 = three (3)-day consecutive suspension from work on all Alberici projects
- » Class 1B + two (2) Class 2 = six (6)-day consecutive suspension from work on all Alberici projects
- » Class 1B + three (3) Class 2 = termination from work on all Alberici projects for a period of not less than one (1) year
- » Class 2 + Class 2 = three (3)-day consecutive suspension from work on all Alberici projects

Note: In all cases after each suspension, the employee shall at a minimum complete a reorientation of the project safety rules that led to the disciplinary action being initiated.

## Suspension/Termination Challenge

Every employee has the right to challenge the determination of a violation or how a violation is classified. The employee may exercise this right by communicating with their general trade superintendent (GTS) through trade leadership or project management.

*A committee of trade leadership, safety, and executive management will hear and review the challenge. Determinations of the Incident Review Committee are final.*

The above disciplinary procedures do not supersede or replace disciplinary actions – including termination of employment – resulting from work rule infractions such as, but not limited to, tardiness, excessive absenteeism, insubordination, substance abuse, and related infractions. Suspensions or terminations of Alberici employees are without pay.

## Project Safety Services Program

This program is an opportunity for an individual to reduce a Safety Protection Policy Class 1B violation to a Class 2.

An individual who has received their first Class 1B shall be given the opportunity to reduce that Class 1B to a Class 2 through the Project Safety Services Program. This is a one-time opportunity to reduce a disciplinary action.

The individual may request this opportunity from the project staff or GTS (as applicable) within three (3) working days after returning to work, and the individual shall complete the following



requirements within two (2) months of the approval. The GTS or a designated project staff person will support and advise the employee during the program; however, it is the responsibility of the employee to meet the obligations.

The individual shall conduct one SafeCard meeting with each Alberici crew on the project.

The employee shall conduct a SafeTalk meeting and complete four (4) SafeTalks in a two-month period. The meetings shall be attended by a member of Alberici project management and shall be documented.

Additional training may be recommended or required, such as online training programs or focused, specific training to help fulfill the requirements of this program.

If another Class 1 or a Class 2 violation is written against this individual in a 12-month period, the Project Safety Services Program shall be canceled.

The reduced violation remains, and the second Class 1 or Class 2 will stand and cannot be reduced.

If the employee is laid off or discontinues employment on Alberici projects during the program period, the employee will be allowed to continue the program requirements when they are next employed on an Alberici project. In the case of re-employment or transfer to a different project, it is up to the employee to advise the project team of their desire to continue the program.



## RECORDKEEPING

This SOP outlines ACI's process for meeting OSHA reporting and recordkeeping requirements for workplace injuries and illnesses. It applies to all U.S.-based operations under federal or state OSHA jurisdiction and assigns responsibilities across leadership, safety, legal, and risk management teams. The Safety Director manages case classifications and ensures severe injuries or fatalities are reported to OSHA within required timeframes, while the Safety Systems Manager maintains a centralized database and prepares annual logs. OSHA 300, 301, and 300A forms must be completed, maintained for five years, and posted as required, with cases recorded within seven days of becoming recordable. The procedure specifies what qualifies as first aid, medical treatment, and OSHA recordable cases, and includes clear definitions for severe injuries, routine duties, work-relatedness, and significant aggravation. Legal provides interpretation of complex cases, and Risk Management communicates medical updates affecting recordability. Through this process, ACI ensures regulatory compliance, consistent reporting, and accurate recordkeeping of occupational incidents.

Click the link to download the [SOP for OSHA Reporting and Recordkeeping](#).



## OSHA INSPECTION GUIDELINES

### Upon Notification of Inspection

- » Be polite, respectful, and cooperative.
- » Notify your safety director immediately for direction and, if possible, request that a safety representative accompany the compliance officer.
- » It is also appropriate to ask the inspector to wait until the highest-ranking official at the project site is located or until Alberici's designated safety representative is notified.
- » Notify your client and trade partners of the inspection and request their presence, where applicable, at the inspection, including the opening and closing conference.
- » Ascertain the cause/purpose for any inspection:
  - If the employer has been selected for an inspection by a neutral process (a programmed inspection)
  - If an accident has occurred
  - If an employee complaint has been filed
  - If the compliance officer has witnessed a violation from outside the premises

In all these situations (other than a programmed inspection), cause exists only to the extent and scope required to investigate the incident, complaint, or violation at issue.

- » Request to see the inspector's credentials.
- » After reviewing their credentials, allow the inspector to enter the workplace without any undue delay.
- » It is appropriate to inquire about the compliance safety and health officer's (CSHO) background. This will establish whether their expertise is in construction or as an industrial hygienist. It makes sense that if someone is to inspect issues regarding scaffolding, trenching and excavation, and fall protection programs, they need to be familiar with the construction standards.
- » Make a copy of their credentials and their assignment for the site.
- » Record all pertinent information. The names, business affiliation, addresses, and phone numbers of everyone present should be written down.
- » Complaints: Ascertain the nature of the complaint (employee, contractor, public).

### Pre-Investigation Conference

Before starting the inspection, the compliance officer will explain the nature of the inspection and the general scope. The compliance officer will outline records they want to review and the employees they want to question. If not already done, notify the following parties that an inspection is underway at the project site:

- » Client
- » Other contractors, subcontractors, and trade partners
- » Alberici's main office, safety director, and/or vice president of safety



## **Rights to Reasonable Inspection**

The OSHA Act guarantees employers the right to a reasonable, orderly, and fair inspection. The inspection must be:

- » At a reasonable time
- » Within reasonable limits
- » Performed in a reasonable manner
- » Conducted to question a reasonable number of employees if there is not an authorized representative of employees

If the investigation involves a complaint, the compliance officer should inspect and interview only with respect to matters reasonably related to the complaint.

## **Avoidance of Disruption**

The Department of Labor’s regulations direct the compliance officer to conduct their investigations to avoid any undue and unnecessary disruption of the normal operations of the employer.

## **What to Do During the Walk-Through Inspection**

Accompanying the officer is an employer’s most important right because you may be the only spokesperson for Alberici during the inspection, as well as the eyes and ears of management for any contest proceeding later.

The OSHA statute gives the compliance officer authority to interview employees and to examine machinery or equipment. Workers have the right to be interviewed in private if they wish. A company representative should be present when management (anyone directing or managing work, including field supervision) is being interviewed.

The compliance officer is permitted to take photographs, use a video camera, take samples, and use other reasonable techniques at the work site. You should also take pictures and samples as close to those of the compliance officer as possible.

Additionally, the officer may record all verbal comments made by the inspection team. You are not required to answer questions posed by the officer. “No comment” is sufficient.

## **Take Pictures and Notes**

It is imperative that you take as complete a set of notes as possible, including identifying areas visited, equipment and material examined, and employees interviewed. Provide a written description of each alleged hazard. There is nothing wrong with taking notes during the investigation.

Ask the officer what they are looking at and to identify the hazard. Where possible, fix hazards while the compliance officer is present. Fixing hazards is not an admission of guilt.

## **Representatives Authorized by Employees**

The OSHA statute provides the right for an employee-authorized representative—often an appointed steward or union safety officer—to accompany the compliance officer.

The statute also states the compliance officer “shall consult with a reasonable number of employees concerning matters of safety and health in the workplace.”



## Post-Inspection Conference and Actions

After an inspector completes the inspection, a closing conference is conducted with the employer representative. The inspector is required to informally advise you of any apparent violation.

Do not agree you violated the act or any standards during the closing conference. Any admission of violation of the OSHA Act can be used later.

Keep very specific and detailed notes of any violations mentioned. If the inspector believes a violation may have occurred, they may tell you that they do not know if Alberici will be cited, but they will ask how long it will take to correct those same conditions.

Items you want to show the inspector during closing are:

- » Copies of minutes of project-site safety meetings
- » Copies of SafeTalks or other employee training materials
- » Copies of safety warnings to individuals, subcontractors, and trade contractors
- » Any other materials that would help establish “good-faith compliance efforts,” such as safety awards, Alberici’s safety manual, etc.

Any correspondence with OSHA should be able to be tracked by registered or certified route and request a signature receipt.

## Written Records

If the project is cited for alleged violations, you should notify the highest level of management immediately in writing following the closing conference.

This report should provide as much detail as possible—for instance, location of alleged violation, what was occurring at the time of inspection relating to the alleged violation, and what sort of investigation techniques or documentation were used by the inspector. Include any photos you have taken.

## Receipt of Alleged Citations

Citations contain a cover letter stating posting requirements. If the citation is sent to the project site, the safety director must be notified and the citation should be forwarded to them at the main office immediately.

## Contesting Citations

From the day you receive the safety order at the project site or your office, you have 15 working days to contest it, excluding all federal holidays. If 15 working days have elapsed and you have not filed a contest, the citation becomes final and binding. You must then pay any assessed penalties and correct all alleged violations.

## Informal Hearings

During the 15-working-day period in which you may contest a citation, you may request an informal hearing. Seeking judicial review does not, however, extend the 15-working-day period. Contact the Safety Department if you plan to contest any part of a citation.



## INCIDENT NOTIFICATION AND INVESTIGATION

This SOP establishes the process for timely notification, reporting, and investigation of all safety, health, and environmental incidents across ACI. It applies to employees, subcontractors, and other covered parties, and clearly defines roles and responsibilities at every organizational level, from the President to frontline employees. Supervisors are responsible for initial notifications, securing the scene, and completing reports, while safety professionals, risk management, and legal provide oversight, support, and regulatory coordination. The procedure outlines timelines for reporting, investigation, and review, with escalation based on the severity of the incident. Investigations are conducted using root cause analysis methods, with findings reviewed by leadership and corrective actions tracked for completion. Shared Learning Summaries are then created to communicate lessons across the company while ensuring confidentiality. Ultimately, this SOP ensures consistent incident handling, accountability, and continuous improvement in safety performance.

Click the link to download the [SOP for Incident Notification and Investigation](#).

SECTION II

# General Safety





## ASBESTOS EXPOSURE CONTROL

The OSHA regulations are found at 29 CFR 1926.1101. There may be additional federal, state, and local regulations.

Whenever asbestos is encountered or even suspected in areas where we are working, the Safety Department should be contacted immediately for assistance. Special licensing and certification are required to perform asbestos-related work, and Alberici will select a qualified, licensed asbestos contractor to perform the work of demolition and repair if asbestos exposure is anticipated. Alberici is not licensed to perform asbestos installation or abatement work. Under no circumstances are Alberici employees to remove or disturb any asbestos-containing material (ACM) or presumed asbestos-containing material (PACM) until verified safe by a qualified entity.

There may be times when we encounter asbestos, either during demolition work or during work by other contractors on site. The following information is provided to acquaint our personnel with the basics of asbestos and the hazards associated with asbestos. The information is not intended to qualify an employee to work with or around ACMs.

### What Is Asbestos, and Where Is It Used?

Asbestos is a combination of minerals (chrysotile, amosite, and crocidolite, and the asbestos forms of tremolite, actinolite, and anthophyllite) obtained from metamorphic rock. Its ability to separate into thin, strong particles makes it highly suitable for use as a noncombustible, nonconducting, and chemically resistant material. In its natural state, asbestos is a fluffy, fibrous material.

Asbestos cannot be recognized by ordinary observation; a sample must be tested in a laboratory using polarized light microscopy (PLM) or an electron microscope. In the construction environment, asbestos may be found in wallboard, drywall tape compounds, pipe coverings, plaster, cement products, transite, cement pipe, roofing materials, laboratory cabinet liners, heating duct insulation, and other areas.

### Multi-Employer Work Sites

On multi-employer worksites, an employer performing work that involves asbestos is required to inform all other employers that asbestos is on site, as well as the requirements pertaining to regulated areas. The contractor is also required to notify other employers, including Alberici, of measures taken to ensure other companies' employees are not exposed to asbestos.

Our employees who are potentially exposed to asbestos are required to comply with applicable protective measures. We may choose to remove our employees from the area until the hazards no longer exist.

If we are working near another contractor or owner who is performing asbestos-related work, we are required to "take steps on a daily basis to ascertain the integrity of the other employer's enclosure and/or the effectiveness of the control method relied on by the asbestos contractor." (OSHA Standard 1926.1101(d)(4).) This measure ensures that our employees are not exposed to friable asbestos as the result of another contractor's failure to perform its duty to contain asbestos fibers.

### Regulated Areas

All asbestos-related work must be performed in "regulated areas." Regulated areas are required to be identified by signs and have warnings posted. Access to regulated areas is limited to authorized persons.



### **Initial Exposure Assessment**

If asbestos is suspected in our work area, we must request the owner to provide evidence that the area is free of ACM or PACM. If we still have concerns, samples should be taken and analyzed by an independent, recognized laboratory before we start work in the area. The Safety Department can assist with contacting an appropriate agency.

All employers performing asbestos-related work are required to perform an initial exposure assessment when work begins and periodic monitoring as the work progresses. If we are working in the same general area where asbestos-related work is underway or planned, we should request a copy of the protocol for their exposure assessments and the results of the required air sampling. This information should be forwarded to the Safety Department for evaluation. If asbestos levels exceed the permissible exposure limit (PEL), we will discontinue work until we ensure there is no exposure to our employees.

### **Subcontracting Asbestos-Related Work**

We may encounter asbestos in our work when owners or other contractors request we subcontract the loading, transportation, removal, or abatement of asbestos-containing material after it is removed from a building. Should this occur, the Risk Management or Safety Department should be contacted before any agreement is made. Generally, we will not perform any type of work related to asbestos, but we will review each instance on its merits.

### **Daily Checklist**

The [Daily Checklist for Asbestos](#) can be used as a reminder of items to confirm if we are working in or near an area where asbestos work is underway.



## BLOODBORNE PATHOGENS EXPOSURE CONTROL PROGRAM

It is in Alberici's best interests to take whatever steps we can to minimize our employees' exposure to workplace hazards, including bloodborne pathogens.

### Purpose of the Plan

OSHA has enacted a bloodborne pathogens standard. Its purpose is to "reduce occupational exposure to hepatitis B virus (HBV), human immunodeficiency virus (HIV), and other bloodborne pathogens" that employees may encounter in their workplace.

Alberici believes that good general principles should be followed when working with bloodborne pathogens:

- » It is prudent to minimize all exposure to bloodborne pathogens.
- » Risk of exposure to bloodborne pathogens should never be underestimated.
- » Alberici should institute as many work practice controls as possible to eliminate or minimize employee exposure to bloodborne pathogens.

We have implemented this exposure control plan to meet the requirements of the OSHA bloodborne pathogens standard. There are two objectives to this plan:

- » To protect our employees from the health hazards associated with bloodborne pathogens
- » To provide appropriate treatment and counseling if an employee is exposed to bloodborne pathogens

### General Program Management

#### *Exposure Control*

Alberici's safety directors act as exposure control officers and are responsible for overall management and support of Alberici's bloodborne pathogens compliance program. They are responsible for:

- » Implementing the exposure control plan
- » Working with management and other employees to develop and administer any additional bloodborne pathogens-related policies and practices needed to support the effective implementation of this plan
- » Improving and updating the exposure control plan
- » Conducting periodic audits to ensure an up-to-date exposure control plan is maintained

#### *Department Managers and Supervisors*

Department managers and supervisors are responsible for exposure control in their respective areas.

#### *Employment Resources Responsibilities*

Employment Resources/Training & Development will be responsible for providing employees with information and training. Their responsibilities include:

- » Maintaining an up-to-date list of personnel requiring training
- » Developing suitable education and training programs
- » Maintaining appropriate training documentation, such as sign-in sheets and quizzes
- » Periodically reviewing training programs with the exposure control officer, department managers, and supervisors



- » Personnel requiring training includes superintendents, general foremen, foremen, safety engineers, project engineers, and project managers
- » Additionally, designated office personnel must have bloodborne pathogen exposure training
- » Refresher training should be conducted on an annual basis

### *Employees*

Employees have the most important role in our bloodborne pathogens compliance program. In this role, they must:

- » Know what tasks they perform that have occupational exposure
- » Attend bloodborne pathogens training sessions
- » Conduct all work in accordance with our bloodborne pathogen controls
- » Develop good personal hygiene habits

### *Availability of the Exposure Control Plan to Employees*

Alberici's Exposure Control Plan is available to our employees at any time through the Safety Department and/or the Commons. Employees must be advised of this availability during their training sessions and/or site-specific orientation.

### *Review and Update of the Plan*

The plan will be reviewed and updated under the following circumstances:

- » When new or modified tasks and procedures are implemented
- » When jobs are revised such that new instances of occupational exposure may occur
- » When we establish new functional positions within Alberici that may involve exposure to bloodborne pathogens

### **Exposure Determination**

To recognize exposure determination, Alberici has identified the following:

- » Job classifications that define all employees who have potential occupational exposure to bloodborne pathogens
- » Job classifications in which some employees have occupational exposure to bloodborne pathogens
- » Tasks and procedures in which occupational exposure to bloodborne pathogens occur

### **Methods of Compliance**

Several areas must be addressed to effectively eliminate or minimize exposure to bloodborne pathogens. The first four areas are:

- » Using universal precautions
- » Implementing appropriate work practice controls
- » Using necessary personal protective equipment
- » Implementing appropriate housekeeping procedures

Each of these areas is reviewed with our employees during their bloodborne pathogens-related training. (For additional information, see "Information and Training" at the end of this section.)



### *Universal Precautions*

We treat all human blood and body fluids as if they are known to be infectious for HBV, HIV, and other bloodborne pathogens.

In circumstances where it is difficult or impossible to differentiate between body fluid types, we assume all body fluids to be potentially infectious.

The designated, on-site safety officer is responsible for overseeing our universal precautions program.

### *Work Practice Controls*

Alberici uses work practice controls that are implemented and overseen by the company safety directors. The safety directors work with supervisors, site safety personnel, and Alberici's training coordinators to put controls into effect.

Alberici has adopted the following work practice controls as part of our bloodborne pathogens compliance program:

- » After removing potentially contaminated gloves or other personal protective equipment, employees wash their hands immediately or as soon as feasible.
- » Following any contact with blood or any other infectious materials, employees wash their hands and any other exposed skin with soap and water as soon as possible. They also flush exposed mucous membranes with water.
- » Eating, drinking, smoking, applying cosmetics or lip balm, and handling contact lenses is prohibited in work areas where there is potential for exposure to bloodborne pathogens.
- » Equipment that becomes contaminated is examined prior to servicing or shipping and decontaminated as necessary (unless it can be demonstrated that decontamination is not feasible).
  - An appropriate biohazard warning label is attached to any contaminated equipment, identifying the contaminated portions.
  - Information regarding the remaining contamination is conveyed to all affected employees, the equipment manufacturer, and the equipment service representative prior to handling, servicing, or shipping.
- » The company safety directors are to be notified for assistance in the event of a large bloodborne pathogen spill or contamination.
- » Ensure new employees are trained in work practice controls:
  - If the employee is transferring from one job to another within Alberici, the job classifications and tasks or procedures pertaining to his or her previous position are checked for potential exposure to occupational bloodborne pathogen hazards.
  - The employee is trained regarding any work practice controls with which the employee is not experienced.

### *Personal Protective Equipment (PPE)*

PPE is our employees' "last line of defense" against bloodborne pathogens. Alberici provides the PPE that employees need to protect themselves against exposure. This equipment includes but is not limited to:

- » Gloves
- » Safety glasses



- » Goggles
- » Face shields/masks
- » Respirators
- » One-way mouthpieces

The site safety leads and supervisors are responsible for ensuring that all work areas have appropriate PPE available to employees.

Our employees are trained in the use of the appropriate PPE. Additional training is provided when necessary.

To ensure that PPE is not contaminated and is in appropriate condition to protect employees from potential exposure, Alberici adheres to the following practices:

- » All PPE is inspected prior to being used and replaced as needed to maintain its effectiveness.
- » Single-use PPE (or equipment that cannot, for whatever reason, be decontaminated) is appropriately discarded.
- » A designated individual should be assigned to inspect first aid kits and PPE used to protect employees from bloodborne pathogens on a weekly basis.
- » Any garments penetrated by blood or other infectious materials are removed immediately or as soon as feasible.
- » All potentially contaminated PPE is removed before leaving the work area.
- » Gloves are worn in the following circumstances:
  - When employees anticipate hand contact with potentially infectious materials
  - When handling or touching contaminated items or surfaces
- » Disposable gloves are replaced as soon as practical after contamination or if they are torn, punctured, or otherwise lose their ability to function as an “exposure barrier.”
- » Masks and eye protection (such as goggles or face shields) are used whenever splashes or sprays may generate droplets of infectious materials.
- » Protective clothing is worn whenever potential exposure to the body is anticipated.

### *Housekeeping*

Maintaining a project site/facility in a clean and sanitary condition is an important part of a bloodborne pathogens compliance program. To facilitate this process, we have established policies that comply with the owner or client when working at each project.

Determine the following:

- » The area to be cleaned/decontaminated
- » Day and time of scheduled work
- » Cleansers and disinfectants to be used
- » Any special instructions that are appropriate to the exposure incident



On-site management is responsible for setting up our cleaning. The following procedures are used with all types of wastes:

- » They are discarded or “bagged” in containers that are:
  - Able to be closed
  - Leakproof if the potential for fluid spill or leakage exists
- » Waste containers are maintained upright, routinely replaced, and not allowed to overflow.



## HEPATITIS B VACCINATION, POST-EXPOSURE EVALUATION, AND FOLLOW-UP

Alberici recognizes that exposure incidents can occur even with good adherence to all our exposure prevention practices. As a result, we have set up procedures for hepatitis B vaccinations and post-exposure evaluation and follow-up if exposure to bloodborne pathogens occur.

### Vaccination Program

Alberici will arrange for a vaccination series against hepatitis B infection.

The series consists of three inoculations over a six-month period and is performed under the supervision of a licensed physician or other licensed healthcare professional (LHCP).

The vaccination program is discussed in our bloodborne pathogens training.

### Post-Exposure Evaluation and Follow-Up

If an employee is involved in an incident where exposure to bloodborne pathogens may have occurred, we immediately focus our efforts on two things:

- » Investigating the circumstances surrounding the exposure incident
- » Ensuring our employees receive medical consultation and treatment (if required) as expeditiously as possible

The safety officer and field supervisor investigate every exposure incident that occurs at an Alberici jobsite. This investigation is initiated within 24 hours of the incident and involves gathering the following information:

- » When the incident occurred; date and time is required
- » Where the incident occurred; location is required
- » What potentially infectious materials were involved in the incident, such as type of materials (e.g., blood)
- » Source of the material
- » The circumstances of the incident, referring to the type of work being performed
- » How the incident was caused:
  - Accident
  - Unusual circumstances (such as equipment malfunction or power outage)
- » Personal protective equipment use at the time of the incident
- » Actions taken because of the incident:
  - Employee decontamination
  - Cleanup
  - Notifications made

After this information is gathered and evaluated, a written summary of the incident and its causes is prepared. Recommendations are then made for avoiding similar incidents in the future.

We recognize that much of the information involved in this process must remain confidential. Alberici will do everything possible to protect the privacy of the people involved.



As the first step in this process, we provide an exposed employee with the following confidential information:

- » Documentation regarding the routes of exposure and circumstances under which the exposure incident occurred
- » Identification of the source individual (unless infeasible or prohibited by law)

Next, if possible, we test the source individual's blood to determine HBV or HIV infection. This information will be made available to the exposed employee if it is obtained. At that time, the employee will be made aware of any applicable laws and regulations concerning disclosure of the identity and infectious status of the source individual.

Finally, we collect and test the blood of the exposed employee for HBV and HIV status.

Once we complete these procedures, we arrange an appointment for the exposed employee with a qualified healthcare professional to discuss the employee's medical status. This appointment includes an evaluation of any reported illnesses, as well as any recommended treatment.

#### *Information Provided to the Healthcare Professional*

We forward relevant documents to the healthcare provider:

- » Copy of the bloodborne pathogens standard
- » Description of the exposure incident
- » Other pertinent information

#### *Healthcare Professional's Written Opinion*

After the consultation, the healthcare professional provides Alberici with a written opinion evaluating the exposed employee's situation. In turn, we furnish a copy of this opinion to the exposed employee.

In keeping with this process's emphasis on confidentiality, the written opinion will contain only the following information:

- » Whether hepatitis B vaccination is indicated for the employee
- » Whether the employee has received the hepatitis B vaccination
- » Confirmation that the employee has been informed of the results of the evaluation

Confirmation that the employee has been told about any medical conditions resulting from the exposure incident that require further evaluation or treatment

All other findings or diagnoses will remain confidential and will not be included in the written report.

#### *Medical Recordkeeping*

To ensure we have all possible medical information available to the participating healthcare professional, Alberici maintains relevant medical records on our employees. The safety officer is responsible for setting up and maintaining these records, which include:

- » Employee name
- » Employee social security number
- » Copy of the employee's hepatitis B vaccination status
  - Vaccination dates
  - Medical records related to the employee's ability to receive vaccination



- » Copies of the results of the examinations, medical testing, and follow-up procedures that took place because of an employee's exposure to bloodborne pathogens
- » Copy of the information provided to the consulting healthcare professional from any exposure to bloodborne pathogens

As with all information in these areas, we recognize the importance of keeping medical information confidential. We will not disclose or report this information to anyone without the employee's written consent (except as required by law).



## COMPRESSED GAS CYLINDERS

### Storage and Care

- » Compressed gas cylinders contain various gases, air, or oxygen under extreme pressure. Cylinders must be handled carefully and not dropped.
- » Cylinders shall be stored, moved, and always used in an upright position. Fuels in storage must be chained or otherwise secured to prevent toppling.
- » Propane (LP fuel) may be stored horizontally in a rack or when transported, but the tanks should never be inverted when empty. Mark empty cylinders as “MT.”
- » Air and oxygen cylinders may be hoisted safely in designated cages, racks, or nets. Acetylene gas cylinders must be kept in an upright position only.
- » Cylinders transported in pickups and other vehicles must be upright and secured with their caps in place.
- » Protective caps shall be kept in place on all cylinders in storage and on cylinders not in use. The valve shall be closed hand-tight prior to installation of the protective cap, and the cap shall always be tightened to the last thread.
- » Oxygen cylinders in storage must be separated from fuel-gas cylinders or combustible materials (especially oil or grease) by a minimum distance of 20 feet (6.1 m) or by a noncombustible barrier at least 5 feet (1.5 m) high having a fire-resistance rating of at least one-half hour.
- » Cylinders shall be stored in cages or racks and shall be secured with chains or otherwise stabilized to prevent them from toppling over. Cylinders stored outdoors shall be protected from snow or ice accumulation and from direct sunlight.
- » Storage containers must identify the gas contained within and have signage posted that warns “FLAMMABLE” and “NO SMOKING.” Fire extinguishers must be located 25 feet to 50 feet away from fuel gas in storage and be readily accessible in the event of a fire.
- » Fire extinguishers should never be so close to compressed gas cylinders to prevent access to them in the event they are needed.
- » Various methods identify the contents within a cylinder. Do not remove, obliterate, or attempt to change or destroy these identifiers.
- » Oxygen under pressure is not to be used in the vicinity of oil, oil mist, grease, solvents, oxidizers, or gasoline.
- » Oxygen under pressure is never to be used for cleaning purposes or blowing off skin, hair, or clothes. Oxygen shall never be used as a substitute for compressed air.
- » While cylinders are in use, the valve key should be kept in place on the valve spindle so the cylinder can be shut off quickly.

### Setup and Use

- » Only approved regulators free from defects, grease, or oil may be connected to compressed gas cylinders. Inspect the valve opening to make sure it is free from obstructions. The valve should be cracked one-quarter turn to blow out any impurities. Stand to one side of the opening, not in front of it. Do not crack the valve near welding work or near other sources of ignition.
- » Cylinders will be firmly secured on carts before attaching regulators.
- » Inspect all hoses and connectors for dirt, grease, or oil. Gas and air hoses taped together for the convenience of keeping the hoses together in parallel shall not be taped more than four inches



out of 12 inches. Defective hose, hose with defective couplings, or hose that shows signs of flashback or wear shall be taken out of service.

- » Torches shall be inspected before each use. Torches showing any leaks in the shutoff valves, hose couplings, or tip connections shall not be used. Torches shall only be lit by friction lighters or other approved devices. Torches shall never be lit by hot work or matches.
- » Regulators are delicate, calibrated instruments and shall be treated as such. Avoid damaging the threads by reattaching the plastic caps and storing the regulators in a case.
- » Regulators shall be attached with a wrench and shall not be over-tightened. Avoid cross-threading and always inspect the threads for dirt or other contamination. Make sure brass parts are clean before attaching to cylinders.
- » After attaching the regulators, turn the adjusting handle on the regulator counterclockwise to release pressure on the diaphragm spring (Alberici requires check valves to be in place with all setups).
- » Open the oxygen valve all the way; open the acetylene valve a half-turn only. Adjust the regulator screws to show a slight pressure. When purging of the system is complete, shut off the torch valves finger-tight.
- » Check the manufacturer's chart for the regulator setting properly suited for the tip size and job application. Adjust the regulator screws to the required pressure.
- » When replacing cylinders on a torch cart, be certain that the caps are in place and snug to prevent them from falling and potentially striking the employee.

**Caution! Always stand to the side of the regulator when slowly opening the cylinder valve. Regulators have been known to explode, causing serious injury.**

### Fuel Gas and Oxygen Manifolds

- » Fuel gas and oxygen manifolds shall bear the name of the substance they contain in letters at least 1-inch high either painted on the manifold or on a sign permanently attached to it.
- » Manifolds shall be placed in safe, well-ventilated, and accessible locations. They shall not be located within enclosed spaces.
- » Hose connections shall be such that the fuel gas and oxygen hose cannot be interchanged.
- » When not in use, manifold and header hose connections shall be capped. Nothing can be placed on top of the manifold that will damage the manifold or interfere with quickly closing valves.



## CONFINED SPACE

Alberici's policy is that any employee who is required to work in a confined space or other hazardous location shall be properly trained and equipped to perform their work without risk of injury or illness. The required training must be documented. Alberici will train employees in confined space entry using criteria based on the General Industry Standard, 1910.146.

### Definitions (Per OSHA)

- » **Acceptable entry conditions:** The conditions that must exist in a permit space to allow entry and ensure that employees involved with a permit-required confined space entry can safely enter and work within the space.
- » **Attendant:** An individual stationed outside one or more permit spaces who monitors the authorized entrant and who performs all attendant's duties assigned in the employer's permit space program.
- » **Authorized entrant:** The employee authorized by the entry supervisor to work in the confined space.
- » **Blanking or blinding:** The absolute closure of a pipe, line, or duct by fastening a solid plate (such as a spectacle blind or a skillet blind) that completely covers the bore and that can withstand the maximum pressure of the pipe, line, or duct with no leakage beyond the plate.
- » **Double block and bleed:** The closure of a line, duct, or pipe by closing and locking or tagging two inline valves, and by opening, locking, and tagging a drain or vent valve in the line between the closed valves.
- » **Emergency:** Any occurrence (including any failure of hazard control or monitoring equipment) or event internal or external to the permit space that could endanger entrants.
- » **Engulfment:** The surrounding and effective capture of a person by a liquid or finely divided (flowable) solid substance that can be aspirated to cause death by filling or plugging the respiratory system or that can exert enough force on the body to cause death by strangulation, constriction, or crushing.
- » **Entry:** The action by which a person passes through an opening into a permit- required confined space. It occurs as soon as any part of the entrant's body breaks that plane of the opening into the space.
- » **Entry permit:** The written or printed document provided by the employer to allow and control entry into a permit space.
- » **Entry supervisor:** The person (such as the employer or the foreperson) responsible for determining whether acceptable entry conditions are present at a permit space where entry is planned, for authorizing entry and overseeing entry operations, and for terminating entry as required by this section.
- » **Hazardous atmosphere:** An atmosphere that may expose employees to the risk of death, incapacitation, impairment of ability to self-rescue (that is, escape unaided from a permit space), injury, or acute illness from one or more of the following causes:
  - Flammable gas, vapor, or mist over 10% of its lower flammable limit (LFL)
  - Airborne combustible dust at a concentration that meets or exceeds its LFL
  - Atmospheric concentration of any substance for which a dose or permissible exposure limit (PEL)/threshold limit values (TLV) is identified in the most recent version of OSHA 1926.55, Appendix A. (PEL and TLV are equivalent terms.)
  - Atmospheric oxygen concentrations below 19.5% or above 23.5%



- » **Hot work permit:** The employer's written authorization to perform operations (for example, riveting, welding, cutting, burning, and heating) capable of providing an ignition source.
- » **Immediately dangerous to life and health (IDLH):** Any condition that poses an immediate or delayed threat to life or that would interfere with an individual's ability to escape unaided from a permit space.
- » **Inerting:** The displacement of the atmosphere in a permit space by noncombustible gas (such as nitrogen) to such an extent that the resulting atmosphere is noncombustible.
- » **Isolation:** The process by which a permit space is removed from service and completely protected against the release of energy and material into the space by such means as blanking or blinding; misaligning or removing sections of lines, pipes or ducts; double block and bleed systems; lockout or tagout of all sources of energy; and blocking or disconnecting all mechanical linkages.
- » **Line breaking:** The intentional opening of a pipe, line, or duct that is or has been carrying flammable, corrosive, or toxic material, and inert gas, or any fluid at a volume, pressure, or temperature capable of causing injury.
- » **Non-permit confined space:** A confined space that does not contain or, with respect to atmospheric hazards, have the potential to contain any hazard capable of causing death or physical harm.
- » **Oxygen-deficient atmosphere:** An atmosphere containing less than 19.5% oxygen by volume.
- » **Oxygen-enriched atmosphere:** An atmosphere containing more than 23.5% oxygen by volume.

### Confined Space Entry Program

Alberici recognizes that it may be hazardous, dangerous, or even deadly for employees to enter a confined space if proper precautions are not taken.

To help protect Alberici employees from incidents and injury in confined-space situations, we have adopted a Permit-Required Confined Space Program. For this program, "confined space" is described as non-permit-required confined space (NPRCS) and permit-required confined space (PRCS).

#### *Non-Permit-Required Confined Space (NPRCS)*

NPRCS does not contain, or have the potential to contain, any hazards that can cause death or serious physical harm and is defined by the following three criteria:

- » Is large enough and so configured that a worker can bodily enter and perform work
- » Has limited or restricted means for entry or exit such as tanks, vessels, silos, storage bins, hoppers, vaults, and pits
- » Is not designed for continuous worker occupancy

#### *Permit-Required Confined Space (PRCS)*

PRCS meets the definition of a NPRCS and has one or more of the following characteristics:

- » Contains or has the potential to contain a hazardous atmosphere (e.g., rusty tank solvents, flammable liquids, chemical residue)
- » Contains a material that could engulf an entrant (e.g., grain silo, excavation)
- » Has an internal configuration that might cause an entrant to be trapped or asphyxiated by inwardly converging walls or by a floor that slopes downward and tapers to a smaller cross-section

*In almost every circumstance, entering trenches and/or excavations is a confined space entry procedure. It is up to the project management staff and Safety Department to determine whether the space is non-permit or permit-required. The AHA must reflect this determination.*



(e.g., hoppers, bins, paint booths)

- » Has mechanical equipment that may start automatically (e.g., pumps, compressors, valves, gates)
- » Contains any other recognized serious safety or health hazards (e.g., welding, cutting, burning, electrical, explosive, or toxic atmospheres)

Alberici personnel shall exercise safety and health precautions whenever an employee is required to perform confined space entry. Scenarios that personnel are likely to encounter include manholes, excavations, storage tanks, bins, hoppers, chutes, process vessels, and large equipment. Familiarity with PRCS definitions and procedures are required so that inadvertent access to a PRCS does not occur without the proper precautions.

All confined spaces meeting the above criteria must be considered permit-required unless specified as a NPRCS by the Confined Space Supervisor.

### Procedures for Identifying a Confined Space

- » Alberici or the subcontractor entering a confined space shall designate a trained and qualified representative to evaluate each workplace to determine the existence and type of confined space in the area where the employees will be working.
- » Before employees are allowed to begin work, the designated representative shall coordinate with the authorized representative of the owner, construction manager, or the general contractor to evaluate the project site and to determine the types of confined spaces that exist.
- » If permit-required spaces are found to exist, the designated representative will identify the location by posting an appropriate sign and notify the Alberici project manager:  
**“Danger: Permit-Required Confined Space—Do Not Enter.”**
- » If employees must enter to perform work in the confined space, they will do so by following the Alberici confined space policy. Subcontractors may use their own confined space entry procedure if it meets or exceeds Alberici and OSHA requirements.

### Coordination with Host Employer

When employees work in facilities containing confined spaces that are controlled by the host employer, the authorized representative shall coordinate all confined space entry requirements with a properly authorized representative of the host employer. The following are examples of information that must be shared by the host employer, who shall:

- » Apprise the contractor representative of all elements, including hazards identified in the confined space; experiences the host employer has had with the space; and, if appropriate, the reasons a space is classified as a permit-required confined space.
- » Indicate any precautions or procedures that have been implemented by the host employer for the protection of its employees in or near the confined space area where employees of the contractor will be working.
- » Coordinate all entry operations to protect both the host employer’s employees and contractor employees who are working near the confined space to be entered.
- » If the host employer’s employees and contractor employees are to work in the confined space simultaneously, written entry procedures shall be developed and implemented to ensure the safety of all authorized entrants and that employees of one employer do not endanger the employees of another employer. Determine whether there will be separated entries, one at a time conducted under separate permits, or if all entry participants are documented on one permit and entries occur simultaneously under one permit.



- » Provide the authorized contractor representative with any available information regarding the permit space hazards and any entry operations mandated by the host employer. Furthermore, the authorized contractor representative shall provide a copy of Alberici's confined space program to the host employer for their review and approval before any contractor employee performs an entry operation.
- » Approve use of Alberici's confined space program as is, or as modified by special requirements of the host employer, in writing and signed before the start of the job. Prior to entry, the written plan shall be approved by an authorized representative of the host employer.
- » Furnish or make available any safety data sheet (SDS) information for the contents, if any, previously contained in the confined space. Contact the Safety Department if you have any concerns or questions.

### Preparation for Entry into a Confined Space

Before entry into a permit space is authorized, the authorized contractor representative shall:

- » Ensure all persons are trained in confined space work and the training is documented
- » Confirm that potential atmospheric, configuration, engulfment, or other recognized hazards have been identified and evaluated by a qualified person
- » Implement all measures necessary to prevent unauthorized entry
- » Assign responsibility and specify acceptable entry conditions
- » Conduct purging, inerting, flushing, or ventilating of the confined space to eliminate or control atmospheric hazards
- » Implement an energy lockout policy, if necessary
- » Determine whether tools and equipment to be used are suitable for the work to be done

### Training Requirements and Responsibilities

All entry supervisors, attendants, and entrants must be properly trained to enter a confined space. Certain critical roles must be defined before any work is conducted in a confined space or a PRCs. The project must also designate a competent person who will be responsible for the overall confined space program on the project.

#### *Entry Supervisor*

This person (such as the employer or foreperson) is responsible for determining whether acceptable entry conditions are present at a permit space where entry is planned, for authorizing entry and overseeing entry operations, and for terminating entry as required by this section.

Responsibilities of the entry supervisor:

- » Knows the hazards of the PRCs. If a hazardous atmosphere may exist, the entry supervisor must know the mode of entry into the body (inhalation, absorption, ingestion, etc.), signs or symptoms, and consequences of exposure.
- » Verifies the permit is properly completed with required signatures and that all procedures are followed
- » Terminates the entry and cancels the permit
- » Verifies that rescue services are available and that the means for summoning help are operable.  
*Do not rely on the owner or local emergency services to be the rescue team in the event of an emergency in a confined space.*
- » Verifies that only authorized entrants are allowed into the confined space



- » Maintains close supervision of the attendants and entrants during entry

### *Authorized Entrant*

The authorized entrant is the employee authorized by the entry supervisor to work in the confined space. Only entrants who have successfully completed PRCS training will be allowed in the confined space. There are no exceptions to this requirement.

Responsibilities of the entrant:

- » Knows the hazards of the PRCS. If a hazardous atmosphere may exist, the employee must know the mode of entry into the body, signs or symptoms of exposure, and consequences of exposure.
- » Uses the PPE required by the supervisor. If respirator use is required, the employee must comply with the Respiratory Protection Program section of this manual
- » Maintains communication with the attendant
- » Alerts the attendant of any hazards encountered or any emergency situations
- » Exits the space if the attendant identifies any hazards

### *Attendant*

The attendant is an individual stationed outside one or more permit spaces who monitors authorized entrants and performs all attendant's duties assigned in the employer's permit space program.

If multiple spaces are to be monitored by a single attendant, include in the site-specific permit program the means and procedures to enable the attendant to respond to an emergency affecting one or more of the permit spaces being monitored without distraction from the attendant's responsibilities. This change will also require all members of the crew to sign off on the special occurrence to the permit system.

Additional responsibilities of the attendant:

- » Knows the hazards of the PRCS. If a hazardous atmosphere may exist, the attendant must know the mode of entry into the body, signs or symptoms of exposure, and consequences of exposure.
- » Is aware of possible behavioral effects of hazard exposure in authorized entrants
- » Continuously maintains an accurate count of authorized entrants
- » Remains outside the space during entry operations. The attendant will not perform any other duties that might interfere with monitoring the PRCS
- » Monitors activities inside and outside the space to determine whether the space is safe for the entrants
- » Summons rescue and other emergency services as soon as the attendant determines that the authorized entrants may need assistance to escape from permit space hazards. The attendant will not attempt any entry rescues.

### **Minimum Equipment Needed for PRCS Entry**

Although the equipment needed to perform a PRCS entry varies depending on the situation, certain minimum equipment is necessary for safe entry:

- » Ladders
- » Portable lighting
- » Ventilation equipment



- » Tripods and harness
- » Communication equipment
- » Atmospheric monitors
- » Personal protective equipment
- » Handrails for vertical PRCS
- » Ground fault circuit interrupter (GFCI) for extension cords

The authorized contractor representative shall ensure that necessary equipment is available on location, that the equipment is in proper operating condition, and that personnel operating or using the equipment have been properly trained.

Appropriate light shall be provided within and outside the confined space. Some of the precautions that shall be taken when selecting lighting are as follows:

- » If the atmosphere inside the confined space is classified as flammable or explosive, the electrical equipment used shall conform to Article 500, National Electric Code.
- » All personnel entering the confined space shall be provided with explosion-proof flashlights if other means of lighting are not available.
- » Extension cords in damp or wet areas could cause electric shock hazards. Only approved low-voltage (6- or 12-volt) lights and extension cords with GFCI shall be used.

### Isolating Energy Sources

Before contractor employees enter any confined space, the space shall be removed from service and completely protected against the release of energy and/or materials into the space. This provision means that all energy sources leading to or located within the confined space that pose potential hazards to the workers shall be locked out, tagged, relieved, disconnected, and/or restrained. If the entry is made into a host employer's confined space, the contractor's designated representative shall verify that all valves, disconnects, pressure piping, and all other energy sources are bled, opened and locked, drained, tested, and relieved of stored energy. Additionally, the contractor's designated person should accompany the host employer's representative and witness the securing of all energy sources. They should satisfy themselves that all energy sources are truly secured: Lock out, tag out, and then try out to ensure all sources are controlled/neutralized.

In some cases, a machine may have more than one energy source (such as high- and low-voltage electrical, electro-hydraulic, electro-pneumatic, etc.). Ensure each energy source is truly locked out.

Energy sources include:

- » Electrical
- » Mechanical
- » Gravity
- » Pneumatic
- » Hydraulic
- » Thermal
- » Radioactive sources
- » Kinetic



The objective for isolating all energy sources is to prevent unexpected or accidental energizing, start-up, or release of stored energy that could cause injury to workers within the confined space.

Before any Alberici employee enters a confined space, the Alberici supervisor shall apply an Alberici lock on the energy source and maintain control of the key. This lock will remain in place until all work is completed and all employees have exited the space and are accounted for. Refer to Lock Out Tag Out procedures for additional requirements.

### Atmospheric Testing

Before entry into any confined space, a qualified person using proper testing equipment that is correctly calibrated must evaluate the atmospheric conditions within the confined space. It is important to understand that some gases or vapors are heavier or lighter than air and will settle at the top, bottom, or center of a confined space. Therefore, it is necessary to test all areas using properly calibrated testing instruments to determine which gases are present and in what quantity.

If any one of the atmospheric tests (oxygen, combustible gases, toxic gases, hydrogen sulfide) is at a concentration above its preset alarm-sounding level, no entry into the confined space can be made. If testing reveals oxygen deficiency or the presence of toxic gases or vapors, the space must be ventilated (blower or fan) and retested before work entry.

Contact the Safety Department with any questions about the safety of the atmosphere.

OSHA requires monthly instrument calibration using certified span gas. Alberici recommends performing weekly span gas calibration (bump checks) when performing confined space work. Monitoring personnel should document their training in meter calibration and follow the manufacturer's guidance enclosed with the instrumentation.

*Never trust your senses to determine whether the air inside the confined space is safe.*

You cannot see or smell many toxic or combustible gases and vapors, nor can you determine the level of oxygen present without properly calibrated atmospheric testing instruments. Only employees trained in the use of atmospheric testing instruments are permitted to do so. Atmospheric testing must be continuous while entrants are inside a PRCS.

- » No compressed gas cylinders will be allowed into the confined space.
- » All compressed gas hoses will be checked for damage before being brought into the confined space.
- » All compressed gas cylinders will be turned off when they are not in use.
- » Any additional equipment brought into the confined space must be identified as suitable for the location and atmosphere.
- » Prior to entering a PRCS, several conditions must be met regarding acceptable atmospheric conditions, as noted below.

### Oxygen Content

An oxygen content of 19.5% to 23.5% is required for entry into a PRCS. No entry is allowed into a space when oxygen levels are at 23.5% oxygen or higher. Spaces that contain less than 19.5% oxygen are immediately dangerous to life or health (IDLH) and may only be entered with special precautions. Oxygen content must be tested first.



### *Flammable Atmospheres*

Two things cause an atmosphere to be flammable: the oxygen in the air and a flammable gas, vapor, or dust in proper mixture. Different gases have different flammable ranges.

An explosion results when a source of ignition, spark, or electrical tool is introduced into a space containing a flammable atmosphere. An oxygen-enriched atmosphere (23.5% Oxygen or above) will cause flammables such as clothing and hair to burn violently when ignited. Both an enriched or an oxygen-deficient atmosphere may affect the operation and interpretation of the combustible gas meter. Therefore, never use pure oxygen to ventilate a PRCS. Always ventilate with normal air. Any PRCS containing 10% or more of the lower explosive limit (LEL) is considered a combustible atmosphere and may not be entered under any circumstance. Mechanical ventilation may be required to reduce the LEL to an acceptable level. Ventilation equipment must be explosion-proof when ventilating a combustible atmosphere. Flammability of the atmosphere must be tested second.

### *Toxic Atmospheres*

Many substances (liquids, vapors, gases, mists, solid material, and dust) can be considered hazardous in a PRCS. Toxic atmospheres in the confined space can occur when substances emit toxic gases or when cleaning residue of a stored product. Any potential toxic gas, vapor, or dust in a PRCS must be continuously monitored, and levels must be kept below the permissible exposure limits (PEL). Use of supplied air and air purifying respirators are allowed in case where exposure near or above a PEL is possible. Refer to Respiratory Protection procedures for additional requirements.

### *Carbon Monoxide*

No employee is allowed to enter a confined space with 25 ppm or greater of carbon monoxide. The OSHA PEL is 50 ppm (time-weighted average).

### *Fire Hazards*

To preclude the possibility of fires occurring that could become a hazard to workers inside the confined space, the following precautions shall be taken at a minimum:

- » Access to and egress from the confined space shall be always maintained clear of any obstructions. If welding or cutting is to be performed in the confined space, combustible materials shall be covered with flame-retardant materials.
- » Flammable liquids (such as acetone and alcohol) shall be stored in UL-listed or FM- approved containers. The number of flammable liquids brought into the confined space shall not exceed the amount needed to perform the work each day.
- » Properly rated fire extinguishers shall be immediately available.
- » Cylinders containing oxygen, acetylene, or other fuel gases shall not be taken into the confined space.
- » All rags, brushes, wipes, gloves, and like materials shall be stored in metal containers with lids. The containers shall be emptied daily.
- » A firewatch person shall be posted during all welding, burning, and heating operations to monitor for fires and ensure that after the work has ceased, or at the end of a work shift, no fire conditions are present.
- » Where flammable liquids or gases are used in confined spaces, continuous monitoring with a calibrated combustible gas detector shall be maintained in the confined space while flammable materials are present.



### *Immediately Dangerous to Life or Health (IDLH)*

All confined spaces have the potential to become IDLH environments. In certain, very rare circumstances, it may be necessary for the trained PRCS rescuers to conduct a rescue in conditions that are already known to be IDLH. Regular work will never be conducted in PRCS that are already known to be IDLH.

Entry is not permitted in PRCS that are known to be IDLH, except for rescue or by written permission of the Safety Department. The following is a list of conditions that are considered IDLH or serious safety hazards:

- » Oxygen content less than 19.5%, or greater than 23.5%
- » Combustible atmosphere over 10% of the LEL
- » Any atmospheric toxin over the IDLH value for that compound
- » Any unguarded fall exposures over 6 feet
- » Any live and exposed energized equipment
- » High-pressure steam lines in poor condition
- » Sustained atmospheric temperatures above 1000° F
- » Unshored or unsloped excavation walls
- » Areas subject to flash flooding
- » Tanks or other vessels not properly ventilated
- » Toxic gases at or near IDLH concentrations
- » Any other IDLH condition

### **General/Physical Hazards**

In addition to the areas discussed previously, evaluation of a PRCS should consider the following potential hazards:

- » Temperature extremes
- » Engulfment hazards
- » Noise
- » Slick, wet surfaces
- » Falling objects
- » Excavation sloping
- » Combustion engines near the PRCS
- » The potential for toxic gases
- » Fire hazards
- » Mechanical equipment that may start automatically
- » Weather conditions outside the space

### **Issuance of a Confined Space Permit**

The following procedures are to be followed when a trained entry supervisor is preparing a permit to enter a PRCS. Only a trained entry supervisor may prepare or sign a PRCS following completion of the tasks below:

- » Review the information on the PRCS entry permit request



- » Determine whether the task can be accomplished without entering the PRCS
- » Determine the exact scope of work, number of employees who will be entering the space, size of the space, hours of work, number of days or shifts, and other information required to complete the permit. Address all health and safety issues (ventilation, PPE, lockout/isolation, potential for atmospheric condition changes in the space, rescue equipment, etc.) during permit preparation. Ensure that adequate barriers are provided to protect entrants and entry attendants from external hazards.
- » Complete Alberici's PRCS entry permit form and perform pre-entry atmospheric testing. Atmospheric testing should be done only by qualified persons using correct equipment that is properly calibrated. Results of the testing should be reviewed by the Safety Department or other qualified person before entry is permitted. The PRCS permit shall be brought to the PRCS entry site and should be reviewed by the entry attendant and entrants.
- » Eliminate any conditions that make it unsafe to remove an entrance cover before atmospheric testing and removing the cover. Also, all required blanking of the process line, locking out of bins and feeders, examination of electrical equipment, and other procedures that can be accomplished without entering the PRCS should be performed at this time.
- » Test the atmosphere to determine whether it meets safe entry criteria. If the entry is to last more than 15 minutes in duration, or there is a significant potential for the atmosphere to change after initial site entry, then continuous monitoring by a trained entry attendant is required. The entry supervisor will also examine the conditions; rescue, ventilation, and communication equipment; entrant qualifications; and other safety-related conditions prior to releasing the PRCS for entry and will sign the permit section that relates to atmospheric testing. The entry supervisor will also determine whether continuous monitoring of the confined space's atmosphere is required. If continuous monitoring is required, it will be in operation before entry is permitted.

Atmospheric testing will occur before ventilation equipment has been turned on. If atmospheric testing indicates that the air in the space is not within safe limits, then the PRCS must be ventilated and the atmosphere retested with the ventilation off. Testing after the ventilation system has been turned on should also be performed; this testing ensures that contaminants from other areas are not being drawn into the PRCS. No entry into a PRCS where atmospheric conditions or other conditions are found to be IDLH will be made without specific written approval from the Safety Department. If rescue of persons in a PRCS involves entry into the space, only rescuers specifically trained in PRCS rescue shall be allowed entrance.

### Entry Procedures

The following procedures apply after the entry supervisor for entry has approved the PRCS ([Confined Space Checklist](#)):

- » The permit must be posted at the entrance to the PRCS. The entry supervisor must sign all posted permits. The permit must be posted continuously throughout the shift and is valid for one shift only. All entrants must review the permit before entering the PRCS. The permit will review some of the safety requirements that must be accomplished prior to any entry into the permit access confined space. The confined space must be periodically tested for three gases: oxygen, carbon monoxide, and flammable gases.
- » All ventilation equipment must be in operation. The entry supervisor should examine the erection of all rescue winches and test them to ensure reliability. The entry attendant should also take up his or her post at the entrance to the PRCS. Testing of communication and communication equipment (two-way frequency radios) between the attendant and the work crew should be performed at this time.



- » After the initial entry into the PRCS, the entrants shall first visually examine the space for obvious hazards, such as exposed electrical and mechanical hazards, fall hazards, and atmospheric hazards. All such hazards will be addressed before proceeding with the scheduled work.
- » The entrants will also examine the efficiency of the ventilation system. If air is not being circulated to all parts of the PRCS, the ventilation system will be modified to do so before continuing with operations.
- » The entry attendant always remains at the entrance to the PRCS. The entry attendant may not leave their post for any reason unless relieved by another trained entry attendant or until all the entrants have left the space and the entrance has been secured. The entry attendant will always remain in contact with the work crew inside the PRCS and will monitor any change in conditions that could affect the health and safety of the work crew. The entry attendant will talk to the entrants at least every five minutes to verify communication ability and to detect changes in the mental status of the entrants that may indicate that a problem exists in the PRCS. If changes in mental status (such as “drunken” or sluggish-type behavior) occur, the entry attendant will cause the PRCS to be immediately evacuated. If adverse conditions occur (or are likely to occur), then the entry attendant will immediately cause the confined space to be evacuated. Such evacuation can be accomplished by communicating with the work crew or, in the case of a vertical entry, by hoisting the entrant using a winch.
- » Under no circumstance whatsoever is the entry attendant to enter the PRCS to rescue any entrants, unless properly equipped and trained for PRCS rescue and properly relieved prior to entry by another trained entry attendant. All entrants must evacuate the PRCS immediately upon instruction to do so by the entry attendant or entry supervisor.
- » At the conclusion of the work performed in the PRCS, the entry supervisor will ensure that the entrance to the space is closed or sealed. The entry supervisor will remove the PRCS permit from its permanent location, write the word “EXPIRED” in large letters across the top, and return the expired permit to the Alberici office, where it shall be filed for one year.
- » Alberici shall perform a review of entry operations when there is reason to believe that the measures taken under the permit space program may not protect employees and will revise the program to correct deficiencies found to exist before subsequent entries are authorized.
- » Examples of circumstances that require reviewing confined space permit:
  - Unauthorized entry into a permit space
  - Detection of a condition in the permit space not covered by the permit
  - Detection of a prohibited permit condition
  - Occurrence of an injury or near-miss during entry
  - Change in the use or configuration of a permit space
  - Employee complaints about the effectiveness of the confined space program

### **PRCS Rescue**

In the event of a fire or medical emergency, the attendant must contact, or get in contact with someone who can contact, the rescue squad. The entry attendant shall have the emergency phone numbers posted near the PRCS. Only trained PRCS rescue squads may enter for rescue purposes. An entry attendant making a call for the PRCS rescue squad must stay at the entrance to the PRCS until the rescue squad arrives or until the entrants have left the PRCS.



### **Rescue Provisions**

Provisions for employee rescue must be established before anyone enters any PRCS. Rescue equipment may include tripods or refractors, full body harnesses, air-supplied respirators, trained rescue personnel, air-monitoring equipment, and any other materials unique to a confined space.

If Alberici is relying on a local fire department or the owner's emergency response team for rescue from confined spaces, we are required to ensure the local service has the appropriately trained persons and the equipment to perform rescue operations. If Alberici intends to perform the rescue operation, contact the Safety Department for information before any entry is attempted. OSHA has very specific requirements for rescue operations, and it is difficult to qualify our employees.

### **Confined Space Entry Permit Forms**

Confined space permit and non-permit entry forms are available on the Commons.



## CRANES AND RIGGING

Cranes are a vital part of any construction operation. The following guidelines are provided to ensure that they handle loads properly, safely, and with greatest efficiency.

### Load Rating Determination

- » The weight of all auxiliary handling devices, such as hoist blocks, headache balls, hooks, and rigging, shall be considered as part of the total load. Additionally, the weight of all items added to the load at the site must be determined and added to the total weight.
- » The operator shall be provided with a copy of the bill of lading, with the item's weight clearly legible, to determine total load weight.

### Crane Inspection

Cranes are required to be inspected daily, periodically, and annually. Daily inspections are performed by the operator before beginning any activity involving the use of the crane. The periodic inspection is to be performed by a designated competent person. Their responsibility is to inspect all machinery and equipment before use monthly, or per manufacturer's recommendations, to ensure it is in safe operating condition ([Monthly Crane Inspection](#)). Any defective equipment will be repaired before continued use. A record of the results of this inspection will be maintained by the rigging superintendent or site manager and must be on record at the project.

A thorough, annual inspection of all hoisting equipment is required to be performed by a competent person certified for inspection by an outside third-party agency. A record of the date and result of this inspection must be maintained in job-site records.

Cranes used in marine applications require annual certification by a government-licensed inspector.

All ropes must be thoroughly inspected before a crane is used. The inspection must certify by record of date of inspection, ID of the rope inspected, and signature of the individual performing inspection.

Cranes shall be inspected:

- » After setup and prior to initial lift
- » Before each shift
- » Monthly
- » After every malfunction
- » Completely on an annual basis

Daily inspection:

- » All control mechanisms for maladjustment interfering with proper operation
- » All control mechanisms for excessive wear of components and co-lamination by lubricants or other foreign matter
- » All safety devices for malfunction
- » Deterioration or leakage in air or hydraulic systems
- » Crane hooks with deformation or cracks, sling, and chokers for broken strands, fraying, or linking
- » Electrical apparatus for malfunctioning, signs of excessive wear, dirt, and moisture accumulation



- » Hooks, which must have spring-actuated closures that operate correctly
- » Adequate and readily available fire extinguisher on crane

Periodic and annual inspections shall be performed in accordance with the manufacturer's recommendations.

Manufacturer's rated load test showing test procedures and confirming the adequacy of all repairs and alterations.

### *Recordkeeping*

- » All records pertaining to crane inspections shall be kept in the maintenance shop with a copy on the project site in the contractor's site field office.
- » If, during any safety inspection, the operator or supervisor cannot produce the required crane inspection sheets, the crane shall be shut down and inspected as soon as possible.
- » All rigging inspected and sized by a qualified rigger or the ironworker rigger responsible for load balance, wind condition assessments, and all elements in the erecting lift
- » Specialty rigging, i.e., spreaders and multi-choker assemblies, must have capacity tags
- » Tag/remove damaged or worn rigging
- » Use mechanical equipment to move rigging as much as possible
- » Inspect the crane daily and fill out daily ticket book
- » Operator is the competent person to inspect crane prior to shift and is fully authorized to stop work for equipment safety deficiencies.

Operator has last call on all picks and must:

- » Maintain load chart on board and assess lifts per load weight and reach
- » Maintain swing radius barricades
- » Obey signals from one designated person

Where radios are used because of an inability to maintain visual contact with the signal person, maintain a separate channel for communications.

Signals from anyone other than the designated signal person will be considered a stop signal and the lift will be stopped until the unsafe condition has been corrected.

### **Crane Setup**

One of the critical factors of proper crane setup is a "firm supporting surface." The crane must be level for maximum capacity. To maintain a level condition, however, the ground surface must be adequate to support the dynamic load of a "working" crane. The most common cause of accidents using rough terrain cranes is poor or improper setup. To clarify Alberici's procedure on setup and operation of rough terrain cranes, the following shall apply:

- » In all cases, the crane manufacturer's recommendations shall not be exceeded.
- » A firm, level foundation capable of supporting the load and crane shall be provided. Regardless of the weight of the load, all lifts and sets must be performed with all four outriggers fully extended and holding all tires within the boundary of the outriggers off the ground.
- » Exception: If, due to configuration or physical location, all outriggers cannot be fully extended and grounded, approval\* must be obtained from the site manager or project superintendent before



making the lift or setting the load.

- » Before approval from the site manager or project superintendent being rendered under this exception, each individual crane setup must be physically reviewed. This procedure does not allow for blanket approvals to be given by the site/project manager.

Pick-and-carry operations are allowed within the following guidelines:

- » A firm, level foundation that will support the crane's load and the weight combined is provided.
- » On all lifts and sets, all four outriggers must be fully extended and holding all tires within the boundary of the outriggers off the ground, or approval is obtained from the site/project manager.
- » Calculations to determine capacity shall be made based on "on rubber" configuration of the load chart.
- » If the manufacturer prohibits lifting "on rubber," pick-and-carry operations are prohibited.
- » Investigate route to be followed for solid and level footing.
- » During carry, the load shall be secured or lashed to ensure stability.
- » An observer must be stationed to warn the operator while the crane, boom, or load is in motion.
- » No one must come in contact with the motorized equipment or load while the equipment is in motion.
- » All tag lines must be constructed of non-conductive material.
- » Installing temporary sleeves on the power line is another precaution to avoid contact with the line. This procedure involves considerable hazard, and using temporary sleeves must be evaluated on a case-by-case basis. Warning flags or other suitable devices may be positioned to define the allowable operating crane of the personnel or equipment.

### Support Needed

Four basic elements are to be considered:

- » Total imposed load
- » Supporting surface area
- » Pounds per square foot
- » Soil stability

#### *Total Imposed Load*

The total imposed load includes the weight of all equipment on the outriggers, including the wind load.

#### *Supporting Surface Area*

The total surface of the outrigger area in contact with the ground and weight of the entire unit will determine the bearing pressure the crane and load exerted on the soil. When it is determined that the load-bearing pressure exceeds soil stability, the bearing area of the soil must be increased by the use of additional cribbing or the load must be reduced.

Cribbing to be used must be:

- » Strong enough to withstand the weight of the crane without major deflection, thus actually increasing the bearing surface
- » Bolted or secured together to prevent slippage or collapsing
- » In complete contact with the soil—no voids, unsupportable areas, etc.



### *Pounds Per Square Foot*

- » Divide the load by the bearing area.
- » Sample: What do you do with a crane and load that weighs 150 tons? Solution: Use four 2 foot x 2 foot floats = 16 SF = 9.38 tons/SF

Remember: Here it is assumed that each outrigger float is carrying 25% of the total load. This is not true in all cases. For example, moving the load over the corner outrigger concentrates a greater percentage of the load on that outrigger. The load percentage on each “corner” will vary, depending on the type of crane and operating radius. A good rule to follow is to assume each corner is carrying 85% of the total load. Thus:

$$\text{One 2 foot x 2 foot float} = 150 \text{ tons}/4 \text{ SF.} = 37.5 \times 0.85 = 31.8 \text{ tons/SF}$$

### **Soil Stability**

Bearing pressure was determined in the above step. This pressure is compared to the load-bearing qualities of the soil. There are basically three types of soils:

- » Granular soils, including sand and gravel
- » Fine-grained soils, including silts and clays
- » Organic soils, including peat

Different types of soils give different load-bearing pressure capability. When setting up a machine, the competent person should be able to distinguish between the three groups of soil, the approximate mixture of each, their moisture contents, and their depth. Factors such as water tables and distance to excavation affect the soil's ability to withstand the pressure without collapsing and must also be considered by the designated person.

Various tables are available that give the relative load-bearing capabilities of the soil types under static loads. Local building code departments are usually a good source for the tables.

### **Critical Lift Parameters**

Certain situations require additional attention, crew coordination, use of additional equipment, and sometimes changing equipment for larger capacity if the current crane in use would be overloaded for a given load. These situations always involve the need for approval from Alberici managers before the lift is to be made. Approval is conditional upon signatures from the project manager, equipment manager, and crane operator on the critical pick document. The critical pick lifting parameters document must be maintained at the site in the project safety files.

Project management will need to consider the impact the loss of a load could have on the project:

- » Loss of life, property damage, equipment damage
- » Possible shutdown of an operating facility and the ensuing litigation
- » Damaged company reputation and loss of future work
- » Inability to meet scheduled deadlines due to lead times for damaged material

Critical lift approval shall be requested for the following situations:

- » Lifts more than 75% of the crane's rated capacity
- » Multiple crane lifts, regardless of percent of rated capacity
- » Lifts over “active” process piping more than 50,000 pounds unless the client's process safety



management (PSM) procedures have a stricter limit

- » Lifts that, either due to the extreme lead time for replacement or value of the material, could adversely affect the project shall have critical pick lifting parameters approved prior to proceeding with the lifts.
- » Lifts that qualify as critical per a client or contractual relationship

### Handling the Load

- » Load Weight
  - No crane shall be loaded beyond its rated capacity.
  - Weight of the load must be positively established before handling. Check brakes and machine stability when load is still only inches above the ground.
  - When loads that are limited to structural competence rather than by stability are to be handled, the operator and supervisor shall concurrently determine that the weight of the load is within  $\pm 5\%$  before the load is lifted.
- » Attaching the Load
  - The load shall be attached to the hook by means of slings or other approved devices.
  - Shakeout hooks are to be used for unloading trucks and moving steel in the laydown area only.
  - The material in the laydown area is to be raised only high enough to clear other material.
  - All other hooks will have safety latches installed or removed from service until they can be replaced.
  - Side loading of the boom is never permitted.
- » Moving the Load
  - The operator shall be responsible for determining that the load is properly secured and balanced before making the hoist.
  - The operator shall position the hook over the load in a manner to prevent load swing.
  - The operator shall determine that the rope is properly seated on the drum and in the sheaves; the load line is non-kinked; and multiple-part lines are not twisted around each other.
  - There shall be at least three wraps of line on the drum at all times.
  - Loads shall be controlled by tag lines free of knots, splices, or defects.
  - Employees in the area will stand clear of the load being raised.
  - Loads will not be moved over personnel.
  - Operator will repeatedly sound horn if load becomes unstable.
  - Operator shall sound a horn before swinging the load over people to give them time to move.

When leaving the control station of a machine, the following precautions should be observed:

- » Disengage the master clutch or shut off the engine
- » Lower the crane load to the ground
- » Set safety pawls on all drums that are manually operated
- » Set the swing brake and both traction brakes and/or locks to prevent machine movement
- » Do not get on or off a machine when it is in motion. Adjustments, repairs, or lubrication is not permitted on moving machinery.



- » No toolboxes, oil cans, choker racks, water coolers, or similar additions may be placed in the barricaded radius of the swing or the counterweight where a person could conceivably be crushed. (Swing radius barricades must be in place.)
- » All crawler-type equipment shall not be moved unless a designated flagger is in full view of the operator giving signals.
- » Accessible areas within the swing radius of the crane’s superstructure will be barricaded to prevent an employee from being struck or crushed. Barricading must be substantial enough to prevent an employee from readily passing through the barrier.

**Crane Work Near Overhead Electric Lines**

- » Using guidelines 1926.550 (a)(15)(i-vii), lines shall be de-energized or grounded or other protective measures shall be provided before work is started.
- » Any overhead line must be considered energized unless it is disconnected and physically grounded.
- » No part of motorized equipment, including the load, may be allowed to get closer to bare live circuits or apparatus than the spacing indicated below:

Nominal Voltage, KV (Phase to Phase)	Minimum Required Clearance (in feet)
0-50	20

*Required Clearances from Live Electrical Lines*

- » For voltages over 50KV, the minimum clearance between the lines and any part of the crane is 20 feet + 4 inches for each 1 kV over 50 kV or twice the length of the line insulator but never less than 10 feet.
- » In transit, with no load and the boom lowered, the equipment clearance is a minimum of 4 feet for voltages less than 50 kV and 10 feet for voltages over 50 kV up to 345 kV and 16 feet for voltages above 345 kV up to and including 750 kV.
  - When it becomes necessary for a crane boom or any part of a crane or similar equipment to be swung, worked, or moved (including in transit between worksites) within the required clearances listed above, the work is to be stopped immediately.
  - The rigging superintendent, site manager and the Corporate Health and Safety Department are to be contacted.
  - These individuals in conjunction with client personnel will decide which of the following steps must be taken.
  - The line must be identified, de-energized, and properly tagged and locked out. The line must also be visibly grounded at the point of work.



## ELECTRICAL

OSHA Standards 1926.400 through 1926.449 apply to the use of electricity on construction sites. The standards are minimal standards for Alberici construction work.

*The basic rule is simple. Consider all electrical wires and equipment live until they are tested and proven otherwise and **LOCK OUT** all power sources.*

A basic element of controlling electrical hazards is that only trained and experienced electricians will perform electrical work on our project sites. All electrical installations will comply with the National Electrical Code (NEC) regardless of where the installation is located.

### Training

- » No person shall install or maintain electrical equipment unless that person has been properly trained or is closely supervised by a qualified person. This includes repair of temporary electrical power cords (extension cords).
- » Employees who face risk of electrical shock but who are not qualified persons shall be trained and familiar with electrically related practices.
- » Employees shall be trained in safety-related practices that pertain to their respective job assignments.
- » Employees shall be trained in the proper and mandatory clearance distances in all aspects of electrical contact or exposure.

### Electrical Hazards

Electrical hazards are found in:

- » Temporary light wiring
- » Connections to existing electrical sources
- » Incoming power lines and panels
- » Extension cords
- » Electrically powered tools and equipment
- » Generators and transformers
- » Existing underground utilities

### Control of Electrical Hazards

Electrical hazards are controlled by a lockout process that must be used any time work is performed on the electrical installation. (See the Lockout/Tagout Procedure section.)

Ground fault circuit interrupters (GFCIs) are mandatory for all 110- and 120-volt temporary electrical circuits on Alberici project sites. OSHA standards permit the use of an assured grounding system, but Alberici will use GFCIs unless the project director or safety director approves other methods. Using an assured grounding system requires a written program, which must be developed before the system is used.

Extension cords will be of the heavy-duty type approved for construction sites and will not have splices. Damaged cords must be removed from the project site immediately. An exception is that new plugs can be installed by a qualified electrician and must comply with the NEC. Cords must have the ground prong intact.



Temporary power supply lines must be routed in areas where they are protected from vehicle and pedestrian traffic and are not subject to excess moisture. Temporary electrical installations should be inspected monthly by a qualified electrician for damage, loose connections, or other conditions that may be detrimental.

Temporary electrical lines should be marked, indicating the voltage carried and the safe distance that should be maintained.

Overhead and/or underground power lines in the work area must be identified and well-marked to avoid contact by cranes, backhoes, trucks, and other equipment.

Temporary power supply boards must be securely mounted, protected from weather and water, accessible to workers, kept clear of obstructions, and protected from accidental contact.

### **Temporary Lighting**

Employees may not enter spaces containing exposed energized parts unless illumination is provided that enables them to work safely.

- » Avoid contact with the wires strung for temporary lighting.
- » Temporary lighting circuits are not extension cords and are to be used as lighting circuits only.
- » Exposed wires should be protected from contact with steel doorframes.
- » Replace missing or burned-out bulbs to maintain required levels of lighting in stairwells, basements, halls, and other areas. Bulbs must be protected with cages.
- » Never fasten light runs, conductors, or bulb holders with nails.
- » Elevate temporary light systems at least 7 feet above the work area.

### **Tools**

If employees are subject to handle dimensional conductor objects (ducts or pipes), steps for safe work practices shall be listed and the employee trained before beginning the task.

- » Use only tools that are properly grounded or double-insulated. Make sure the casing of double-insulated tools is not cracked or broken. Electric power-operated tools either shall be the approved double-insulated type or grounded in accordance with Subpart K of the OSHA Construction Regulations.
- » Use hand tools with insulated handles and grips. When required, wear protective equipment such as goggles, insulated gloves, and shock-resistant footwear.
- » Protective shields, protective barriers, or insulating materials shall be provided as necessary.
- » Do not hold water pipes or other grounded conductors when using electric tools. A defect in the tool or cord will make you part of the circuit, causing shock, a fall, or electrocution.
- » Before drilling, hammering, or cutting with hand or power tools, check for electrical wires or equipment behind walls, above ceilings, and under floors.
- » Never bypass broken switches on tools or equipment by plugging and unplugging the cord. Have the switch repaired.
- » Any shock or tingle, no matter how slight, means that the tool or equipment must be removed from service immediately and repaired.
- » Use only wooden or fiberglass ladders where electrical conductors are nearby.
- » GFCIs are required for all cord sets and extension cords, as well as for hand-held tools.



- » The person using the tools must inspect all electrical tools prior to use. Defective tools must be removed from service.

### **General Safety Practices and Procedures**

- » Accidents involving electricity occur most frequently when the work is performed on or near live circuits and when manual switching operations are performed. All employees should make every effort not to work any electrical circuits that are energized!
- » No person shall install or maintain electrical equipment unless that person has been properly trained or is closely supervised by a qualified person.
- » Always assume that electrical lines and equipment are energized until circuits have been properly isolated, grounded (if appropriate), tagged, locked out, and tested. Strictly follow all the procedures in the Lockout/Tagout Procedure section of the Alberici Health and Safety Manual.
- » If a circuit cannot be de-energized or clearance cannot be met, obtain approvals and take precautions required before proceeding with the work.
- » Do not use metal ladders or scaffolds in or around high-voltage areas.
- » If an electrical circuit breaker trips, that breaker shall not be reset until an electrician has investigated why the breaker tripped.
- » Never direct a stream of water on electrical conductors without approval of an electrical supervisor who can confirm that all circuits are de-energized.
- » Do not work within 10 feet of bare live circuits above 50 kV that are not barricaded or covered. The 10-foot measurement must be from the nearest part of the body or handheld object.
- » Even when work in distances meet or exceed 10 feet, good judgment must be exercised to ensure that all appropriate precautions are considered. During issuance of work permits, always identify and discuss any electrical power lines, tag and lock procedures, and effective communications. Consult with an electrical specialist when appropriate.
- » Contact with insulated aerial conductors must be avoided. Never assume that insulation on conductors is intact or that it provides adequate personnel protection from a shock hazard.
- » Always replace and tighten all bolts and covers on electrical housings, especially on explosion-proof equipment. These covers and bolts must be in place and tight to maintain the explosion-proof character of the equipment. If this is not done, the equipment could become a source of ignition. Never operate electrical equipment in a hazardous area without the enclosure cover being properly bolted (or screwed) in place.
- » In the event of an emergency/suspected electrocution, do not rush to the victim's aid before considering the source of the problem. Immediately de-energize the circuit if possible. If there is any doubt as to whether the circuit is still energized, carefully remove the victim from the circuit using insulated materials so as not to endanger the rescuers. Insulated materials include dry lumber, a leather belt, a rubber hose, and other non-conductors.
- » The effect that electrical shock will have on an individual depends on the type of circuit, the voltage, resistance, amperage, and pathway through the body. Electric shock normally stops the heart and voluntary breathing reflex. Call for help immediately, start CPR, and continue until medical help arrives.

### **Power Lines**

- » Locate all underground and overhead services before starting work. Determine voltage of electrical utilities, if possible.



- » Mark underground lines on all plans and drawings. Post warning signs along their route.
- » Avoid storing materials under power lines.
- » In areas to which access is not restricted to qualified persons only, materials or equipment may not be stored closer to energized lines or exposed energized parts of equipment than the following distances, plus a distance that provides for the maximum sag and side swing of all conductors and for the height and movement of material-handling equipment:
  - For lines and equipment energized at 50 kilovolts or less, the distance is 3.05 meters (10 feet).
  - For lines and equipment energized at more than 50 kilovolts, the distance is 3.05 meters (10 feet) plus 0.10 meter (4 inches) for every 10 kilovolts over 50 kilovolts.

These distances are intended to ensure worker safety when operating equipment or conducting construction activities near power lines. If voltage is unknown, the minimum safe distance should be assumed to be 45 feet, and additional measures like de-energizing lines or using barriers are recommended.

*Before moving ladders, pulling scaffolding, or elevating work platforms, always check for overhead lines. Serious injuries and fatalities have been caused by contact with equipment.*

### Electrical Shock

Effects of electrical shock can range from a tingling sensation to death. A shock that may not be enough to kill or even injure can startle a worker and possibly cause a fall from a ladder or work platform.

Burns are the most common shock-related injury. Electricity can cause severe burns at points of entry and exit. That damage is often more serious than it looks; bone and muscle can be extensively burned between the entry and exit points.

Shock can also cause irregular heartbeats, leading to respiratory failure and cardiac arrest. Three main factors determine the effect of shock on the body:

- » How much current is flowing through the body (measured in amperes and determined by voltage and resistance)
- » The path of current through the body
- » How long the body is in the circuit

Circuit breakers and fuses open at 15, 20, and 30 amperes. It only takes 1/10 of an amp to kill a person in good health. GFCIs break a circuit at 5 to 7 milliampers. If a GFCI opens or disconnects, it is detecting leakage in excess of 5 to 7 milliampers. Steps should be taken to determine the cause of the malfunction.

### Procedures for Unbroken Electrical Contact

- » In some electrical accidents, the injured or unconscious person remains in contact with the live wire or equipment. Rescue should only be attempted after power has been turned off.
- » In some cases of low voltage, break contact if possible when power cannot be turned off. Use a dry board, rubber hose, or dry polypropylene to move either the injured person or the line.

*WARNING: Touching the injured person, even with dry wood or rubber, can be dangerous. High voltage can jump a considerable gap, and objects that are normally insulators may become conductors.*



- » An object can sometimes be thrown to separate the injured person from the wire.
- » If you don't know the voltage, treat it as high.

In the event of an electrical emergency, always call emergency services—in most cases, ambulance, fire department, and utility.

### **Preventing Electrical Shock**

Grounding of electric tools and machines is one of the most important factors in the control of hazards of low-voltage electricity.

If the insulation in electrical equipment should break down, or if the wire should become loose and contact a non-current-carrying part of the machine, the frame and other parts of that tool or machine become energized. The electricity has escaped the normal bounds of the insulated wire and is ready to follow a path to ground. If a properly grounded wire is attached, the current will follow that wire. If there is no such wire and someone touches the tool or machine, they become part of the circuit as the electricity goes through them to ground. The extent of injury they receive will be dependent on the factors previously mentioned.

### **How to Ground**

- » Motors and equipment with permanent wiring are grounded by connecting the grounding conductor to the frame (or other non-current-carrying metal parts) using suitable lugs, pressure connectors, or clamps.
- » Portable equipment may be grounded by means of a grounding conductor run with the circuit conductors in the cable assembly or flexible cord provided an approved multiprong plug or equivalent is used.

### **Installation Safety Requirements**

- » Alberici shall ensure that electrical equipment is free from recognized hazards that are likely to cause death or serious physical harm to employees.
- » All equipment shall have the manufacturer's name and trademark placed on it. All disconnecting means shall be legibly marked to indicate their purpose.
- » Live parts of electrical systems operating at 50 volts or more shall be guarded against accidental contact by cabinets or other forms of enclosure.
- » Since electrical power is inherent in almost every workplace, all supervisors shall be familiar with the requirements of this policy and supervise their jobs accordingly.
- » Supervisors responsible for employees involved in electrical installation or maintenance shall ensure compliance with the training requirements.
- » Employees working on or in the vicinity of electrical circuits or equipment shall do so safely and according to training and instructions received.
- » The site safety representative shall assist the site manager in maintaining compliance with this policy.
- » The site safety representative shall monitor field activities and keep site management informed of these monitoring results.
- » Alberici's Safety Department will assist site management in maintaining compliance with this policy, as well as provide the expertise necessary to ensure the success of the Alberici Safety Program.



## Inspection and Storage

### *General Precautions*

- » Clearly visible identification plates must be provided for each permanent electrical device located in the work area.
- » Identical nomenclature must be used on all isolating devices coinciding with the equipment served.
- » Equipment having auxiliary circuit must have “Has Auxiliary Circuit” on the identification plate.
- » Identification plates and lettering should be attached in the best practical manner and not affect the existing electrical classification.
- » Temporary lights shall be equipped with guards to prevent accidental contact with the bulb.
- » Disconnecting means shall be located so they are readily accessible.
- » Disconnect boxes shall be securely fastened to the surface upon which they are mounted and fitted with covers.
- » Waterproof disconnect boxes shall be used in damp and wet locations.
- » Always stand to the side when operating any disconnect switch. This will offset your body in case of a malfunction in the switch. If the handle is on the right, use the left hand. If it is on the left, use the right hand.
- » Working spaces, walkways, and similar locations shall be kept clear of cords.
- » Portable electric lighting used in moist or explosive atmospheres (drums, tanks, vessels, pipes, etc.) shall be operated at a maximum of 12 volts.

### *Cords and Portable Tools*

- » All extension cords, portable electric tools, and equipment shall be of three-wire type.
- » Portable tools will have any trigger lock devices removed.
- » Flexible cords shall be used only in continuous lengths without splices unless the insulation is equal to the cable being spliced and wire connections soldered.
- » Cables passing through work areas or across roadways shall be covered or elevated.
- » Worn or frayed electric cables shall not be used.
- » Extension cords shall not be fastened with staples, hung from nails, or suspended by wire.
- » Never use the cord of a tool for carrying or lowering materials; use a tag line.

### *Low-Voltage Lighting Systems*

- » Only low-voltage, explosion-proof lighting shall be used inside a vessel where flammables may be present.
- » The transformer must always remain outside of vessel or hazardous area.
- » Always protect the transformer from moisture and rain.
- » Only qualified electricians may change the bulbs in low-voltage lighting systems.
- » All voltage testers are to be kept clean and in good operating condition.
- » Voltage tester leads should be kept in a separate pouch (other than tool pouch) to prevent damage by other tools in the tool pouch.



- » Before using the voltage tester, you must test it on a known live source to ensure it is operating correctly. If a circuit tests dead, check the voltage tester again on a live source to ensure a correct reading.
- » Always make sure that voltage being tested does not exceed the meter's rating.

### Protective Clothing

Conductive items of jewelry or clothing shall not be worn unless they are rendered non-conductive by covering wrapping or other insulating means.

All job sites should require that subcontractors use and maintain the following protective clothing for certain electrical switching or electrical emergencies and work involving circuits of 480-volt or above:

- » Nomex jacket with double Nomex front
- » Nomex #115 face shield hood or equivalent
- » KV rubber gloves with leather protectors
- » When using a meter to check any voltage over 500 volts, high-voltage rubber gloves shall be used to help ensure safety of our personnel.
- » Phasing sticks must be used when verifying that circuits 1000 volts or greater are de-energized. Phasing sticks must be tested before and after use.
- » Compliance with National Fire Protection Association (NFPA) requirements is mandatory, and contractors/subcontractors must be aware of their responsibility to follow them.

Dielectric switchboard matting is recommended on the floors surrounding fuse boxes and control panels where frequent electrical work is done.

Protective clothing for flash protection must be worn when performing the following functions:

- » Racking in and out breakers and/or starters 480 volts or above
- » Removing and replacing potential transformers in metal switch gear
- » Phase-testing circuits 2400 volts and above
- » Operating emergency stop push buttons on doors of 2400 volts and above

**NOTE: All high-voltage protective clothing shall be stored, maintained, inspected, and tested according to the manufacturer's recommendations. Visually inspect each item immediately prior to use.**

### Electrical Work Requirements

The following functions/duties can be performed only by qualified electricians and authorized by the site manager.

- » Operate any circuit switching device 480 volts or above, except motor starters and valve operators from push button stations
- » Test or troubleshoot electrical equipment
- » Repair or alter electrical equipment
- » Remove or install fuses
- » Climb electrical poles

**NOTE: Only authorized employees may enter energized electrical substations and motor control centers. Unauthorized employees must be accompanied by a qualified electrician.**



- » Perform work on non-insulated energized circuits and apparatus over 50 volts
- » Perform work within 10 feet of non-insulated energized circuits and apparatus that are not barricaded, covered, or otherwise guarded to prevent electrical shock hazards and contact by tools, equipment, or personnel.

All electrical work shall be planned and completed in accordance with the National Fire Protection Association's guidelines for electrical safety in workplaces.

### Red Concrete

Red concrete is typically poured around underground electrical conduits to indicate their location and to protect them against damage. When excavating, do not assume that because there is no red concrete that there are no electrical hazards. Monitor the site and hand dig when appropriate.

Whenever red concrete is encountered during excavation, the job should be stopped until a decision is made on how to handle the red concrete. If possible, modify the job to avoid the red concrete duct bank.

When digging around a red concrete duct bank, assume that the duct bank contains live circuits in non-metallic ducts at the surface and on the top and sides and is completely exposed on the bottom. If it is necessary to trench under a red concrete duct bank, the circuits should be de-energized, if possible.

If this is not feasible, excavation should proceed well below the concrete and with caution until it is certain that no exposed conduits are present. Also, care must be taken not to undermine the concrete duct bank to the extent that it will crack or settle. Backfill under the duct bank should be well tamped.

When excavating under duct banks, you must be assured that the bank is properly shored to prevent damage to the conduit.

Never use a duct bank as a walkway across an excavation.

If it appears that red concrete must be cut, take the following steps in the order shown:

1. Contact the electrical engineer assigned to the project to see if the job can be changed. If the red concrete cannot be avoided, proceed to the next step.
2. Trace all conduits in the concrete duct bank as completely as possible and arrange to have the circuits de-energized. If all circuits are positively identified and de-energized, work may proceed without further approval necessary.
3. Before cutting red concrete containing a known live circuit, the site manager must decide that the equipment cannot be shut down.
4. *Never cut red concrete containing a known live circuit in a non-metallic duct.*
5. Before cutting red concrete containing a known live circuit, contact the maintenance or construction manager responsible for the job and ask that the job be reviewed. If the manager agrees that the work must be done and can be done safely, a detailed listing of the work to be done must be prepared by the site manager and approved and signed by the maintenance/construction manager or designate.
6. Cut the red concrete using the following precautions:
  - Assume there is a live circuit in the concrete duct.



- Use a chipping gun no larger than 40 pounds.
- The person cutting the concrete should wear tested rubber gloves and protectors, rubber boots, and goggles.
- If the duct bank contains one or more known live circuits, do not cut the conduits.
- If the duct bank contains no live circuits, cut a small hole (notch) with a hacksaw in each conduit as it is exposed. Blow air into the conduit to verify the identification at the pull points.
- After conduits have been exposed and identified as dead, a larger chipping gun may be used.

### **Ground Fault Protection**

GFCIs are intended to prevent electrocution by quickly interrupting the circuit in the event of a ground fault. They operate independently of the equipment grounding circuit. The Assured Equipment Grounding Conductor Program requires periodic inspection and testing of the ground circuit. Regardless of which choice is made, all the grounding requirements of the NEC still apply.

The regulations pertain only to the use of temporary wiring on construction sites. They do not apply to the permanent wiring of the building or structure.



## EXCAVATION AND TRENCHING

This section outlines all necessary precautions to protect workers while working in trenches or excavations and to prevent damage to underground utilities and/or other underground obstructions.

Projects must be aware that OSHA has a National Emphasis Program (NEP) regarding safety in trenches and excavations, and an inspection may occur without notification.

This procedure is to ensure workers are not exposed to hazards or unsafe conditions in trenches or excavations.

*In many situations, excavations and trenches are also confined spaces.*

*No worker will be permitted to enter any trench or excavation until the appropriate sections of this program are followed, including validation of training and permitting.*

### Planning

Before any work begins, the contractor or subcontractor must appoint a competent person. Duties of the competent person include:

- » Conducting daily inspections of the excavation for evidence of situations that could result in cave-ins, indications of failure of the protective systems, hazardous atmospheres, and other hazardous conditions.
- » Ensuring the daily Trenching and Excavation Permit is completed by the competent person and reviewed and signed off by a member of Alberici's management team.
- » Ensuring the equipment operator signs off on the permit acknowledging their understanding of the conditions and safe work expectations of the permit.
- » Instructing employees not to enter the excavation when hazardous conditions exist.
- » Identifying any changes in conditions that make the excavation hazardous.
- » Understanding that any trenching or excavating must not begin without a completed and signed permit.

In the event of multi-employer project sites, the excavation contractor will appoint the competent person. Alberici must ensure the person is correctly performing the duties of a competent person before we rely on their judgment. However, at times when the excavation contractor is not working on site and the excavation remains open with no one working Alberici must maintain a competent person on site.

In the event employees of other subcontractors work in trenches or excavations, that subcontractor is responsible for the appointment of its own competent person. Alberici should ensure the subcontractor has appointed a competent person and they are performing the duties as required. Contractors should provide Alberici with written notification of the name and title of their designated competent person. If there is a question regarding their ability to perform the responsibilities of a competent person, Alberici project management is responsible for notifying the subcontractor of their concerns and ensuring the competent person is qualified to perform the tasks.

Other considerations include:

- » Traffic
- » Nearness of structures and their condition



- » Soil
- » Surface and ground water
- » Water table
- » Overhead and underground utilities
- » Weather
- » Availability of equipment required
- » Protection of the excavation while it is open
- » Training for workers

Underground installations (e.g., sewer, telephone, water, fuel, and electric lines) encountered while digging must be located and verified before work begins. If underground installations are uncovered, they must be properly protected and supported. The utility companies involved must be contacted and informed of the proposed work before starting the trench or excavation.

A Live Utility Awareness Permit is required when trenching or excavating is within 10 feet of any utility (live or otherwise). A member of Alberici management must sign the permit.

No mechanical digging is allowed within 3 feet of any known utility. The use of soft digging such as hydro-vac, potholing, and hand digging with non-conductive tools is required.

### Utility Locating Service

The appropriate local or state utility locating service shall be notified of any planned excavating activities a minimum of 72 hours prior to the work to respond to that request. If the utility locating service, utility company, or owner cannot respond within the 72-hour period, the owner may allow the contractor may proceed, provided it is done with extreme caution, detection equipment, or other acceptable means to locate utility installations are used. Typically, utility companies will not enter commercial private property to locate utilities, and other means to identify locations must be used. Up-to-date as-builts are a source. They must be in a common area and available to all contractors and their partners performing trenching and excavations. Excavation permits will not be signed off if the as-builts are not consulted first.

When excavation operations approach the estimated location of underground installations, the exact location of the installations shall be determined by safe and acceptable means. This means hand digging when the excavation approaches 3-5 feet from the staked area.

While the excavation is open, underground installations shall be protected, supported, or removed as necessary to safeguard employees and protect the underground utilities themselves.

### Requirements for Excavations

An excavation is any manmade cut, cavity, trench, or depression in an earth surface formed by earth removal. If excavation permits are required, essentially any soil disturbance except staking is considered an excavation. Be aware of the specific project/owner requirements regarding permits.

*Alberici excavation procedure requires that all compacted or soft and unstable soil be sloped, shored, sheeted, braced, or otherwise supported and that such soil be effectively protected when hazardous ground movement can be expected.*



Every employee entering an excavation shall be protected from cave-ins by an adequate protective system. The project manager will ensure compliance with this requirement.

The only exceptions to this requirement are:

- » If excavation is entirely in solid rock
- » If excavation is less than 5 feet in depth (1.52 m) and examination by a competent person provides no indication of a potential cave-in

### Compliance Methods

1. Slope the sides to an angle no steeper than one and one-half horizontal to one vertical (34 degrees measured from the horizontal). These slopes must be excavated to form configurations that are in accordance with those for Type C soil. Type C is the loosest of the soil types and is the likeliest to collapse. Sloping to this angle or less generally will be sufficient provided there are no sources of vibration or water accumulating. “Benching” shall not be used unless the contractor has evaluated soil and classified it as Type B cohesive or Type A. Where such classifications have been made, “benching” will conform to applicable OSHA regulations. (See item 5 of this section.)
2. Shoring, shielding, or sheeting, are tightly placed timber shores, bracing, trench jacks, piles, or other materials installed in a manner strong enough to resist the pressures surrounding the excavation. Shoring and shielding are often used when there is not adequate space to slope or bench soil.
3. For trench shield (a prefabricated frame), steel, aluminum, or other suitable construction may also be used, but it must be either designed or approved by a registered professional engineer. OSHA standards permit the use of a trench shield if the protection it provides is equal to or greater than the protection that would be provided by the appropriate shoring system.

### Designing Adequate Protection (Sloping, Sheeting, Bracing) and Soil Classification

The type of soil must be identified to determine proper protective measures. Excavations in wet soil, sandy soil, or areas that have been backfilled are relatively unstable and must have strong support. Even hard rock sometimes can be hazardous; faults in the strata can make it unstable when cut.

1. Stable rock is defined as natural solid mineral matter that can be excavated with vertical sides and remain intact while exposed.
2. Type A soil is cohesive with an unconfined compressive strength of 1.5 ton per square foot (tsf) (144 kPa) or greater.

Examples of cohesive soils are clay, silty clay, sandy clay, clay loam, and in some cases silty clay loam and sandy clay loam.

Cemented soils such as caliche and hardpan are also considered Type A.

No soil may be classified Type A, if:

- » The soil is fissured.
- » The soil is subject to vibration from heavy traffic, pile driving, or similar effects.
- » The soil has been previously disturbed.
- » The soil is part of a sloped, layered system where the layers dip into the excavation on a slope of 4 horizontal feet to 1 vertical foot (4:1) or greater.



- » The material is subjected to other factors that would require it to be classified as a less stable material.
1. Type B is cohesive soil with an unconfined compressive strength greater than 0.5 tsf (48 kPa) but less than 1.5 tsf (144 kPa). It includes:
    - Granular cohesionless soils, including angular gravel (similar to crushed rock), silt, silt loam, sandy loam, and in some cases silty clay loam and sandy clay loam
    - Previously disturbed soils except those that would otherwise be classed as Type C soil
    - Soil that meets the unconfined compressive strength or cementation requirements for Type A but is fissured or subjected to vibration
    - Dry rock that is not stable
    - Material that is part of a sloped, layered system where the layers dip into the excavation of a slope less steep than 4 feet horizontal to 1 foot vertical (4:1), but only if the material would otherwise be classified as Type B
  2. Type C is cohesive soil with an unconfined compressive strength of 0.5 tsf (48 kPa) or less.
    - Granular soils including gravel, sand, and loamy sand
    - Submerged soil or soil from which water is freely seeping
    - Submerged rock that is not stable
    - Material in a sloped, layered system where the layers dip into the excavation on a slope of 4 horizontal to 1 vertical (4:1) or steeper

### Weather Conditions

Changing weather conditions and climate also greatly affect how strong a shoring system must be. Excess moisture from rain or melting snow loosens the soil, drastically increasing the pressure on the shoring system. A rainstorm can turn a stable trench side that requires only a light bracing into a mass of loose soil, posing an immediate threat to the employees working within. Even excessively dry conditions can reduce the cohesiveness of the soil.

Inspection of any trench or excavation must take place after a rainfall.

### Superimposed Loads

- » Superimposed loads in the vicinity of a trench or excavation increase the pressure on excavation faces.
- » Heavy equipment and materials shall be kept as far back from the excavation as possible. When heavy loads must be located near an excavation, the walls shall be braced, sheet-piled, or shored to safely support the extra weight.
- » Buildings, curbs, trees, utility poles, and other structures adjoining the excavation area also can place more stress on a trench side than it can safely accommodate. In these instances, shoring, bracing, or underpinning shall be provided as necessary by the contractor.
- » Spoils (the excavated material) can exert great pressure on the excavation walls. Spoils shall be stored 2 feet or more from the edge of the excavation and be retained in an effective manner.



## Vibrations

Vibrations or sudden shock from passing vehicles or railways, blasting, equipment such as trucks or pile drivers, and some tools can contribute to cave-ins by loosening the soil.

## Other Considerations

Besides the three items above, the contractor shall also consider the following:

- » Depth of cut
- » Water content of soil
- » Other operations in the vicinity
- » Hazardous atmospheres

The atmosphere in excavations greater than 4 feet in depth must be tested where oxygen deficiency or a hazardous atmosphere exists or could reasonably be expected to exist before any employee enters the excavation. If hazardous conditions exist, entry into the excavation will not be permitted until the condition is corrected.

Fissures in the soil, some naturally occurring and some caused by excavation activities, can cause pockets of underground gases to flow through the fissure and into the excavation. The entire length of the excavation will need to be tested, and at different levels, because of gases stratifying or laying in layers. This is extremely important if employees are bent over in the bottom of the excavation tying rebar, connecting soil pipe sections, etc.

## Special Precautions

OSHA standards require that diversion dikes and ditches or other suitable means be used to prevent surface water from entering an excavation and to provide adequate drainage of the area adjacent to the excavation. Water causes soil erosion and softening and shall not be allowed to accumulate in a trench or excavation.

Employees shall not work in excavations in which water has accumulated, or in excavations in which water is accumulating unless adequate precautions have been taken to protect the employees against the hazards posed by water accumulation. The precautions necessary to protect employees adequately vary with each situation but could include special support or shield systems to protect from cave-ins, water removal to control the level of accumulating water, or use of a safety harness and lifeline.

If water is controlled or prevented from accumulating by water removal equipment, a competent person shall monitor the water removal equipment and operation to ensure proper operation.

## Vehicular Traffic

If employees are exposed to vehicular traffic—either public traffic or traffic on the project site—they must be provided and required to wear warning vests or other suitable garments made of highly visible material. If employees are required to act as flaggers, they should be trained in traffic control and provided with communication equipment, as needed.

## Emergency Rescue

Emergency rescue equipment, such as breathing apparatus, tripods, safety harness and lanyard, and other equipment, must be readily available when hazardous atmospheres may occur suddenly.



Employees entering bell-bottom pier holes and other confined spaces will comply with the confined space section of this manual.

Before entering excavations that have unique hazards, the local fire department or rescue service should be contacted to determine its response time and equipment it can provide for a rescue. Most rescue squads have NOT been trained in excavation safety and will require you to make the excavation safe for the rescue team before they attempt a rescue.

Emergency response teams must be identified and trained and have equipment readily available. Contact the Safety Department if you have any questions.

### **Responsibility and Authority**

The excavating contractor shall ensure that there is coordination and communication between work groups and individuals so each individual has a complete understanding of planned work activities.

### **Employee Training**

Project managers must ensure that all existing and new employees are properly trained in these excavation/trenching requirements. Training shall be documented.



## FALL MANAGEMENT PROGRAM

Alberici is committed to protecting our employees and subcontractors from falls. The following mandatory requirements and procedures apply to all Alberici operations.

### Fall Prevention and Fall Protection

The objective of fall prevention is to stop a fall from occurring in the first place by creating barriers or solutions that prevent access to hazardous areas.

Examples:

- » Guardrails around elevated work surfaces
- » Hole covers over floor openings
- » Use of platform ladders
- » Warning lines or physical barriers
- » Work platforms with built-in safety features
- » Fall restraint (system designed to restrict a worker's movement, ensuring they cannot access unprotected edges or openings where a fall could occur)

The objective of fall protection is to minimize the risk of injury if a fall occurs by allowing work in areas with fall hazards while using equipment to reduce the severity of a fall.

Examples:

- » Personal fall arrest systems (e.g., point of anchorage, full body harness, and connecting device, e.g., lanyard, lifeline, or self-retracting lifelines)
- » Safety nets
- » Positioning systems
- » Rope grabs for controlled descent

Fall protection is required when workers are at heights of 6 feet or more above a lower level and are not otherwise protected from falls using fall prevention means such as guardrails, hole covers, or similar.

**Exception:** Alberici requires that all personnel use a personal fall-arrest system any time work is performed from an aerial lift—including scissors lifts, aerial baskets, any other type of aerial work platform, or other equipment where the manufacturer, client, owner, or other authority requires the use of fall protection. There is no exception to this requirement.

**Exception:** When work performed is covered by OSHA's General Industry requirements, fall protection is required at 4 feet or more and the worker is not otherwise protected from falls using fall prevention means such as guardrails, hole covers, or similar.

### Responsibilities

Project management is responsible for implementing and enforcing the Fall Management Program.

The Safety Department can assist with compliance as needed. The Safety Department will specify the type of fall protection equipment to be used.



Procurement personnel are responsible for purchasing, distributing, and maintaining the equipment. Alberici will issue personal fall protection equipment. Other fall protection systems are permitted on Alberici project sites with approval by the Safety Department. Personnel desiring to use their own fall protection system must have the equipment approved by a member of Alberici's Safety Department prior to use.

### **Fall Protection Plan**

OSHA Standard 1926.502(k) describes the requirements of a Fall Protection Plan that is required during leading-edge work, pre-cast concrete erection, and residential construction. There are other situations where a Fall Protection Plan may be required or recommended; contact the Safety Department for assistance.

### **Training Requirements**

#### *Awareness*

All employees will be trained to recognize general fall hazards in the work environment. Training will include the thresholds and activities that require fall protection and/or fall prevention.

#### *Performance*

Employees who perform duties requiring or potentially requiring exposure to a fall greater than 6 feet will be trained on additional hazards and means of protection, including but not limited to:

- » Nature of the fall hazards in the work areas
- » Hierarchy of controls measures
- » Personal protective equipment
- » Connecting devices, such as lanyards, rope grabs, and retractable lifelines
- » Anchoring devices
- » Use and operation of guardrail systems, safety net systems, warning line systems, safety monitoring systems, and controlled access zone
- » Inspection requirements and practices
- » Applicable rules and regulations

#### *Competent Person*

Employees designated as competent persons for fall protection/prevention received additional training in the areas of:

- » Hierarchy of control measures and selection of fall protection/prevention approach
- » Personal protective equipment
- » Connective devices
- » Fall Protection Plans
- » Stopping work and hazard correction

#### *Qualified Person*

Employees or consultants designated as qualified persons for fall protection/prevention will receive additional training in the areas of:

- » Design of custom fall protection systems, such as horizontal lifelines or anchorages, to ensure they meet safety standards
- » Determining the strength and integrity of systems



- » Overseeing the installation of complex fall protection systems to ensure compliance with OSHA regulations

### *Trainers*

Training must be conducted by a competent person who has:

- » Knowledge of fall hazards
- » Experience in fall protection systems and their application

### *Certification of Training*

Alberici shall comply with training requirements by issuing and maintaining written or electronic certification records identifying the employees trained and the dates of the training.

Where written, the training records (signed by the person who conducted the training) shall be maintained at the project site.

### *Retraining*

Alberici shall retrain employees if we have reason to believe that an employee who has already been trained does not have the understanding and skill required.

Reasons for retraining include but are not limited to:

- » Change in the workplace that makes previous training obsolete
- » Changes in the types of fall protection systems or equipment to be used makes previous training outdated
- » Inadequacies in an employee's knowledge or use of fall protection systems or equipment, indicating the employee has not retained the necessary skills

### **Positioning Devices**

- » Positioning devices are not a substitute for personal fall protection. A combination of personal fall protection and a positioning device must be used if a worker plans to be held in place while their hands are free to work.
- » The use of body belts is not permitted for use of Alberici worksites.
- » Alberici requires that full-body harnesses are required whenever positioning devices are used.

### **Anchor Points**

- » Anchor points used in a fall prevention system must be capable of supporting at least 5,000 pounds per person attached or must be designed, installed, and used as part of a complete fall arrest system that maintains a safety factor of at least two, under the supervision of a qualified person.
- » Anchor points should be placed to minimize free fall distance and swing fall hazards.
- » Anchor points must be stable, secure, and capable of withstanding expected forces without failure.
- » Anchor points must be identified and evaluated by a qualified person to ensure compliance with OSHA standards.
- » Workers should not use guardrails, ladders, scaffolds, or similar structures as anchor points unless these are specifically designed and rated as anchor points.
- » Anchor points should be inspected regularly to ensure they remain in good condition and are free



from corrosion, damage, or other compromising factors.

- » Structural steel may not be acceptable anchorage for fall protection until the building has been substantially constructed.
- » Structural steel may require analysis by a qualified person before it is used for fall protection.
- » Some owners have specific requirements about what can or cannot be used as a fall prevention system.
- » Alberici has several approved types of anchorage connectors that are available for use, where designed and approved by a competent (or qualified) person.
- » Contact the Safety Department if you have concerns about anchor points.

### Equipment Selection

Competent person is responsible for selecting the equipment with the appropriate fall arrest distance.

To calculate the fall arrest distance:



## Fall Clearance Calculation Chart

To determine the required **Fall Clearance** add the appropriate factors together, this will give you the safe **Required Distance (RD)** below the anchorage connection point for work which is to be carried out where there is any risk of falling.

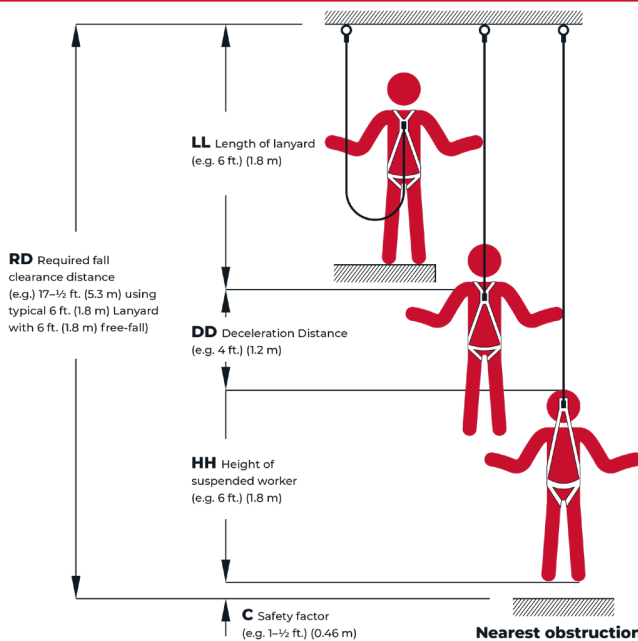

$$RD = LL + DD + HH + C$$

1. Add 1 ft. to **DD** for free-fall over 6 ft. (1.8m) up to 12 ft. (3.6m) or for person over 310 lbs. (140.6 kg) up to 420 lbs. (190.5 kg) with 6 ft. (1.8m) max. free-fall for ANSI & OSHA compliant lanyards.
2. Add 1.7 ft. (0.52 m) to **DD** for Canadian CSA Z259.11-05 (E6) compliant lanyard.
3. D-ring slide and harness stretch factors are built into **C**.
4. **DD** shown in e.g. assumes maximum allowable amounts.
5. See User Instruction Manual for additional information.



If you have any doubts about which fall protection product to use, contact the Safety Department.

### Retrieval

This system is used primarily where workers must be lowered into tanks, vessels, manholes, and other examples of confined space entry and may require retrieval from above should an emergency occur. The equipment must be in place before entry occurs. The following is a typical personal retrieval system:

- » Full body harness
- » Connecting device (retractable lifeline)
- » Attachment point: Tripod
- » Additional equipment may be required – review the work and AHA to determine necessary equipment

### What to Do in Case of a Fall

If a fall occurs, all components of the fall arrest system should be removed from service and turned over to the Safety Department. A fall can substantially decrease the strength of all parts of the system, so all components should be replaced after a fall.

All harnesses, lanyards, and other equipment shall be visually inspected before use. A competent person shall regularly inspect for wear, damage, elongation, and corrosion.

### Arrested Fall Rescue

Jobsites are required to evaluate the expected areas of fall hazards and develop plans for employee rescue in the event an employee sustains an arrested fall. The fall rescue plan must be in place and communicated to all employees with fall exposure potential prior to work beginning. These plans may include numerous areas that will have to be revised from time to time because of site conditions and equipment availability. Some areas to consider include:

- » Structural steel
- » Elevator shaft
- » Tank or pit
- » Roofing work
- » Work from suspended scaffolds

The areas can be difficult to assess, and what works for one may not work for another. If a crane was listed as the means of rescue but can't be cut loose from a piece of ductwork, is down for repairs, or is no longer on the site, then its use is not an option.

The jobsite will have to address different means of rescue as conditions and areas change, then communicate those changes to the crews by training them so there is no delay in providing the proper response to someone hanging in their harness.

### Suspension Trauma

Suspension trauma is a risk to any worker who may suffer a fall and remain suspended. If a hazard assessment identifies such a risk, there must be a rescue plan that co-workers can use immediately in the event of a fall. This can include the availability of a retrieval system and/or the use of trauma straps on the site.



## FIRE PROTECTION

Besides the potential for loss of life, a fire on any construction project can significantly affect the quality, schedule, and cost of the project itself and adversely affect business reputations. To minimize possible risk of loss because of fire, fire protection, and prevention regulations have been developed.

### Fire Protection Requirements

- » Temporary fire protection measures—such as the installation of fire extinguishers, hose lines, and temporary standpipes near hazardous locations—shall be provided as required. Local jurisdictions may have specific requirements and should be consulted at the start of the project.
- » Fire hydrants shall be accessible and protected from damage during construction activity.
- » Fire hoses shall be provided where directed or required.
- » The installation of underground sprinklers and standpipes in buildings shall proceed in concert with construction as required in the specifications.
- » Access shall be maintained at all times to existing or newly activated fire extinguishers, fire hydrants, and fire department connections.
- » Access to excavations, material storage areas, fuel storage areas, and structures shall be maintained at all times for fire department entry. Fire trucks are very heavy, and project site roadways should be maintained to carry the weight of trucks.
- » Emergency phone numbers will be conspicuously posted near all work site phones.
- » A fire emergency plan—including fire department response and emergency medical services—should be developed for the work site at startup and updated as the project progresses.

### Fire Prevention Requirements

- » Good housekeeping shall be maintained at all times.
- » Combustible refuse from construction operations shall not be burned or dumped on the construction site. Such refuse shall be removed at frequent intervals, as needed.
- » Storage of large quantities of construction debris shall be in metal dumpster containers on the site.

### Flammable Liquids

Flammable liquids can be stored outside, away from buildings, in a safe and secure location in standard approved storage cans or tanks. However:

- » Portable tanks shall not be nearer than 20 feet from any building under construction.
- » Storage shall be away from open flames.
- » Storage shall not present exposure to materials or structures.
- » Storage shall be designated by signs and labels, i.e., “gas only” or “diesel only.”
- » Storage areas shall be kept free of weeds, debris, and other unnecessary combustibles.
- » Owner requirements may specify other criteria such as “Storage of flammable materials must be a minimum of 50 feet from any occupied building.” Be aware of owner-specified requirements before the work begins.
- » Plastic fuel containers are not acceptable on any Alberici project.
- » Engines must be shut off during refueling. Funnels shall be used for fueling if the safety can does not have a flexible nozzle.



- » No more than 25 gallons of flammables may be stored inside buildings or in tool trailers. Safety cans shall be used for indoor storage and handling. Cans shall be kept in good condition and inspected regularly.
- » Fire extinguishers must be readily accessible outside the tool trailer if any flammables are stored within. The tool trailer must be labeled “Flammable Storage.”
- » Absolutely no smoking is permitted near any flammable liquid storage area. “No Smoking” signs shall be posted.
- » Storage of flammable liquids inside any occupied building is absolutely prohibited.
- » No wood or other combustible material (including noncombustible materials in combustible wrapping) shall be stored inside areas under construction, under or adjacent to combustible scaffolding, in structures, or in falsework.
- » To avoid exposure, the safe storage location shall be located away from flames and sparks and away from buildings.
- » Separation of piles shall be used to prevent fire spread.
- » Storage of compressed gases (i.e., oxygen, acetylene) shall be in accordance with National Fire Protection Association (NFPA) and OSHA regulations or more stringent customer requirements.

Gas cylinders (i.e., acetylene, oxygen, and LP gas) shall be:

- » Stored on a solid base with valve caps in place
- » Secured to rigid support to prevent toppling
- » Separated by 20 feet or half-hour-rated wall when stored
- » Empty compressed gas cylinders are to be separated from full cylinders and conspicuously marked

### Temporary Heating Devices

- » Solid fuel (wood/coal) salamanders and open drum/barrel fires are prohibited.
- » Adequate insulation must be provided on combustible floors.
- » Adequate fresh air shall be provided to maintain worker health and safety. When fresh air supply is not adequate, some form of mechanical ventilation shall be provided.
- » Temporary heaters will not be used in confined spaces.
- » Temporary heaters will be checked for correct operation before being put into service each day. Heaters will not be modified or altered.
- » Where temporary heaters are used, a CO monitor must be in place.
- » Temporary heaters will not be used in any area where normal operations are underway or exposures exist to visitors, staff, or the public.
- » Where temporary heaters are used continuously, a worker must be assigned to remain in the area as a fire watch.

*The use of either open drum/barrel fires or defective, modified, or altered temporary heating devices exposes employees and the project itself to severe risk of loss from fire or explosion. Their use is absolutely prohibited.*



## Employee Training

- » The project manager shall ensure that all existing and new employees are properly trained in fire prevention and protection regulations, including the use of fire extinguishers ([Fire Extinguisher Data](#)).
- » Training shall be documented.
- » Employees shall also be trained in the emergency evacuation plan developed for the site, the emergency access routes, and any responsibilities they may have in the case of an emergency.

## Responsibility and Authority

Project superintendents and foremen are assigned the daily responsibility and have the authority to ensure that the provisions of this program are implemented and enforced.



## EMERGENCY FIRST AID

### Legal Aspects of First Aid

Legally, no one can be forced to provide first aid or CPR. If someone chooses to do so, the Good Samaritan Law states that they are not liable for actions taken as long as they do not do anything grossly negligent or that constitutes willful misconduct. Trained personnel must never do more than they are trained to do and must never accept payment. If the victim is conscious, always ask permission to treat their injury.

### Basic First Response for Medical Emergencies

Alberici will make available trained personnel on all project sites for advice and consultation on matters of occupational health. We will make provisions before start-up for prompt medical attention for on-site injuries and other emergencies. It is the responsibility of the project manager to ensure these items are provided before work begins at any project site.

Each project shall have onsite, fully stocked and sized first-aid kits that are easily accessible when required and supplies to accommodate the needs of the project. The number and type of items will be developed for the number of personnel on site. The first-aid kits shall consist of appropriate items stored in weatherproof containers with individual sealed packages of each type of item per the latest version of ANSI standard Z308.1.

Appendix A of CFR 1910.151 (non-mandatory) addresses minimum contents of a generic first-aid kit. This kit is dependent on the number of personnel it services. The greater the number of people on the project site, the more first-aid supplies are required. On all projects, a listing of first-aid items must be included in each container. The contents of each first-aid kit shall be checked before being sent to each project. It shall also be checked and verified when it is received on the project.

Each project's first-aid kit shall be checked weekly to ensure that the expended items are replaced. The project is responsible for assigning personnel to perform the inspections. Assigned check-off sheets and verifications shall be kept inside each kit for the inspectors' initials.

Local clinics and hospitals are to be selected and contacted prior to start-up to determine their capability to treat the types of injuries that may occur and to ensure they are prepared and well-qualified. The Risk Management department personnel can assist in determining suitable providers.

In the event a medical provider is not "reasonably accessible" (OSHA terminology) in terms of time and distance to the project site, we are required to provide a person onsite who has a valid certificate in first-aid training. "Reasonably accessible" has been interpreted to mean available within five minutes. This person must agree to be available to treat injured persons and can be anyone who possesses a valid certificate in first aid and CPR and agrees to provide treatment. Having more than one certified person onsite is preferable to ensure we have someone available anytime work is underway.

The Safety Department can assist in providing training on the project site.

### Project Site Medical Service from Off-Site Providers

The Risk Management department will assist in locating a medical facility to treat injured workers. These clinics should be aware of Alberici treatment protocols, including our modified duty policy.



Phone numbers for each medical provider, ambulance service, fire department, and other emergency responders should be posted at every telephone and every vehicle on the project site, as well as being furnished to each person who is provided a mobile phone or radio.

### **Onsite Medical Service**

If an onsite medical facility is available, the Safety Department should be contacted for assistance in determining the level of care that can be provided.

The medical staff should be qualified to treat work-related conditions. Their treatment facility should be adequately stocked with advanced first-aid supplies.

Persons seeking on-site medical treatment should be referred to their personal physician if their condition is not work-related; however, the medical staff may provide basic assessments, such as temperature checks and blood pressure reading. Documentation of anyone treated at the on-site medical facility should be maintained with patient privacy in mind.



## FLOOR AND WALL OPENINGS

### General

- » “Floor hole” means an opening measuring 2 inches or more in its least dimension in any floor, roof, or platform through which materials, but not persons, may fall, such as a belt hold, pipe opening, or slot opening. These should be identified and covered or barricaded while construction is ongoing. Think of floor holes on a walking surface as trip hazards and ankle twisters. When the hole is overhead, it can be a hazard for falling objects.
- » Floor holes into which persons can accidentally walk shall be guarded by either a standard railing with standard toe board on all exposed sides or a floor hole cover of sufficient strength to support the weight of any load that may be imposed and secured against displacement. While the cover is not in place, the floor hole shall be protected by a standard railing.
- » “Floor opening” means an opening measuring 30 inches or more in length and 18 inches or more wide in its least dimension in any floor, roof, or platform through which persons may fall to a lower level.
- » Floor openings will be covered or protected by standard railings immediately after they are created. If covered, the covers should be painted with a “highly visible” paint for awareness and include the word “Hole” or “Cover.” Covers must be secured in place to prevent accidental shifting and exposure.
- » Floor openings shall be guarded by a standard railing and toe boards or cover. In general, the railing shall be provided on all exposed sides.
- » Ladderway floor openings or platforms shall be guarded by standard railings with standard toe boards on all exposed sides (except at entrance to openings), with the passage through the railing either provided with a swinging gate or so offset that a person cannot walk directly into the opening.
- » Temporary floor openings shall have standard railings.
- » Wall openings are gaps or voids of 30 inches or more high and 18 inches or more wide in a wall or partition through which an employee can fall to a lower level.
- » Each employee working on, at, above, or near wall openings (including those with chutes attached) where the outside bottom edge of the wall opening is 6 feet or more above lower levels and the inside bottom edge of the wall opening is less than 39 inches above the walking/working surface, shall be protected from falling by a guardrail system.
- » Every open-sided floor or platform 6 feet or more above adjacent floor or ground level shall be guarded by a standard railing, or the equivalent, on all open sides, except where there is entrance to a ramp or fixed ladder. The railing shall be provided with a standard toe board beneath the open sides wherever persons can pass, there is moving machinery, or there is equipment with which falling materials could create a hazard.
- » Regardless of height, open-sided floors, walkways, platforms, or runways above or adjacent to dangerous equipment, pickling or galvanizing tanks, degreasing units, and similar hazards shall be guarded with a standard railing and toe board.
- » A standard railing shall consist of top rail, intermediate rail, toe board, and posts, and shall have a vertical height of approximately 42 +/- 3 inches from upper surface of top rail to floor, platform, runway, or ramp level. The top rail shall be smooth-surfaced throughout its length. The intermediate rail shall be halfway between the top rail and the floor, platform, runway, or ramp. Employees cannot construct rails from material that could snag clothing or rip flesh. Do not use double-headed nails when constructing rails with 2x4s, and ensure that the wood, metal, or other



material is free from rough edges, burrs, or other hazards.

- » The ends of the rail shall not overhang the terminal posts except where such overhang does not constitute a projection hazard.
- » Minimum requirements for standard railings under various types of construction are specified below:
  - For wood railings, the posts shall be of at least 2- by 4-inch stock spaced not to exceed 8 feet; the top rail shall be of at least 2- by 4-inch stock; the intermediate rail shall be of at least 1- by 6-inch stock.
  - For pipe railing, posts, top, and intermediate railings shall be at least 1½ inches nominal diameter with posts spaced not more than 8 feet on centers.
  - For structural steel railings, posts and top and intermediate rails shall be of 2-by-2-by-3/8-inch angles or other metal shapes of equivalent bending strength, with posts spaced not more than 8 feet on centers.
- » Anchoring posts and framing members for railings of all types shall be of such construction that the completed structure shall be capable of withstanding a load of at least 200 pounds applied in any direction at any point on the top rail, with a minimum of deflection.
- » A standard toe board shall be 3 ½ inches minimum in vertical height from its top edge to the level of the floor, platform, runway, or ramp. It shall be securely fastened in place and have not more than ¼-inch clearance above floor level. It may be made of any substantial material, either solid or with openings not over 1 inch in greatest dimension.
- » A stairway or ladder is needed at all breaks of elevation greater than 19 inches. This includes when work is being performed in trenches and excavations. Bench the slope to create steps or place a ladder for access.

Employees must be trained on the content of this standard and the training documented and kept on site.



## HAND AND PORTABLE POWERED TOOLS

Hand and portable power tools used on our project sites may be owned by Alberici or individual employees. Regardless, all tools are required to conform to the OSHA standard for hand and power tools – construction standard Subpart I and applicable state and local requirements.

The company warehouse issues tools to the project sites and makes repairs when tools are returned from project sites. Personnel are responsible for proper care of all tools and to tag and remove them from service when damaged or defective.

### Hazard Recognition

Each project must have an established procedure to identify defective tools and have them repaired. This process should include tools owned by employees or others that are used on our project sites.

If Alberici believes an employee's personal tools are damaged or defective, the company reserves the right to inspect the tool and/or direct the employee to remove the tool from service.

Hand and power tool inspection should be included in the weekly project site inspections, SafeTalks, and daily walk-through observations of the work area.

Tool use should be included in the appropriate AHA and SafeCard.

### General Safe Work Practices for Hand and Portable Power Tools

- » Hand tools should be kept in good condition and used only for the job intended.
- » Inspect all hand and power tools thoroughly before each use.
- » Defective hand tools should be reported to your immediate supervisor. Common defects include burred, battered, mushroomed, spalled, split, broken loose handle, worn teeth on wrenches, etc.
- » Be aware that hand tools with plastic handles are designed for comfort. They are not designed for electrical insulation.
- » Flying debris is a normal occurrence when using power tools. Recognize this fact and be aware: Warn people around you and use proper personal protective equipment.
- » Be certain that all electrical-powered tools are grounded and/or double insulated. Do not forget to inspect the cord when completing daily tool inspections.
- » Recognize the limitations of the tool. Don't force tools beyond their limitation or use "cheaters" to increase their capacity.
- » Know the tool you are using. Learning about the tool by using it is a major cause of accidents and injuries. If you don't know how a tool operates, ASK.
- » Be familiar with the tool you are using. If the tool has movable parts, they may jam up. Be sure you have good body position and the ability to secure the tool without injuring your hands, fingers, legs, face, etc. Loose clothes may get wrapped up in these movable parts as well.
- » Use proper operating procedures. If a tool is designed to have a guard, use it. If you need to change a part, drill bit, saw blade, etc., unplug the tool before adjusting the tool to your needs. Battery-powered tools must have the batteries removed when they are not in use or in storage.
- » Use proper accessories for your tool. Do not interchange parts unless manufacturer specifications allow this to be done.
- » Do not alter any tool. If the tool needs to be serviced, tag the tool and take it out of service.



## Tool-Specific Safety Precautions

### *Hand Tools*

Hand tools are non-powered. They include anything from axes to wrenches. The greatest hazards posed by hand tools result from misuse or improper maintenance. Some examples:

- » Using a screwdriver as a pry bar may cause the screwdriver to break and fly, hitting the user or other employees.
- » If a wooden handle on a tool such as a hammer or an axe is loose, splintered, or cracked, the head of the tool may fly off and strike the user or another worker.
- » A wrench must not be used if its jaws are sprung because it might slip.
- » Impact tools such as chisels, wedges, or drift pins are unsafe if they have mushroomed heads. The heads might shatter on impact, sending sharp fragments flying.

Employees and the employer are responsible for the safe condition of tools and equipment. Employees are required to notify their project leaders when tools are defective or require replacement.

Appropriate personal protective equipment—safety glasses or goggles, face shields, gloves, etc.—shall be worn because of hazards that may be encountered while using hand tools.

Each task and tool must be evaluated and the appropriate tool and related PPE reflected in the AHA and SafeCard.

Around flammable substances, sparks produced by iron and steel hand tools can be a dangerous ignition source. Where this hazard exists, spark-resistant tools made from brass, plastic, aluminum, or wood shall be used. Workers must be made aware if they are working in an area that could be hazardous because of explosions.

### *Power Tool Precautions*

There are several types of power tools, including electric, pneumatic, liquid-fuel, hydraulic and powder-actuated. Power tools may have a cord, hose or battery operated.

Power tools can be hazardous when improperly used.

Employees shall be trained in the use of all tools—not just power tools. They shall understand the potential hazards as well as the safety precautions to prevent those hazards from occurring.

Power tool users shall observe the following general precautions:

- » Power tools should be sent to the project site with manufacturer's instructions. If the instructions/operating manual is missing, contact the warehouse for a replacement manual.
- » If a guard or handle comes with the tool, it must be used with the guard or handle.
- » Never yank the cord or the hose to disconnect it from the receptacle.
- » Disconnect tools when not in use, before servicing, and when changing accessories such as blades, bits, wheels, and cutters.
- » Secure work with clamps or a vise, freeing both hands to operate the tool.
- » Tools should be maintained with care. They should be kept sharp and clean for the best performance. Follow instructions in the user's manual for lubricating and changing accessories.
- » All portable electric tools that are damaged shall be removed from use, tagged "Do Not Use" and



returned to the warehouse for repair.

- » Brace or secure the tool when in use to prevent it from binding up and/or kicking back.
- » Batteries must be removed when the tool is not in use or when performing any type of maintenance or parts replacement.

### *Guards*

Gears, shafts, pulleys, sprockets, spindles, drums, fly wheels, chains, or other reciprocating, rotating, or moving parts of equipment must be guarded.

Guards are provided to protect the operator and others from the following:

- » Point of operation
- » In-running nip points
- » Rotating parts
- » Flying chips and sparks

Safety guards must never be removed when a tool is being used.

Example: Portable circular saws are equipped with guards. An upper guard must cover the entire blade of the saw. A retractable lower guard must cover the blade, except when it makes contact with the work material. The lower guard must automatically return to the covering position when the tool is withdrawn from the work.

One of the only times it is okay to not wear gloves is when operating tools with rotating shafts or spindles. Gloves can be caught, causing hands to be pulled into the tool. Review the AHA to determine whether gloves are appropriate for the task.

### *Safety Switches*

The following hand-held powered tools are equipped with a momentary contact “on-off” control switch:

- » Drills
- » Tapers
- » Fastener drivers
- » Horizontal, vertical, and angle grinders with wheels larger than 2 inches in diameter
- » Disc and belt sanders
- » Reciprocating saws
- » Saber saws
- » Other similar tools

These tools also may be equipped with a hook-on control, provided that a single motion of the same finger or fingers that turn it on can accomplish turnoff.

The following hand-held powered tools may be equipped with only a positive “on-off” control switch:

- » Platen sanders
- » Disc sanders with discs 2 inches or less in diameter
- » Grinders with wheels 2 inches or less in diameter



- » Routers
- » Planers
- » Laminate trimmers
- » Nibblers
- » Shears
- » Scroll saws and
- » Jigsaws with blade shanks ¼-inch wide or less

Other handheld powered tools—such as circular saws having a blade diameter greater than 2 inches, chain saws, and percussion tools without positive accessory holding means—must be equipped with a constant pressure switch that will shut off the power when the pressure is released.

### *Corded Electric Tools*

Employees using electric tools must be aware of several dangers; the most serious is the possibility of electrocution.

- » Using ground fault circuit interrupters (GFCIs) is required for all electric power tools.
- » GFCIs shall be tested daily prior to use.

To protect the user from shock, tools must either have a three-wire cord with ground or be grounded, be double insulated, or be powered by a low-voltage insulated transformer.

Three-wire cords contain two current-carrying conductors and a ground conductor. One end of the grounding conductor connects to the tool's metal housing. The other end is grounded through a prong on the plug.

Any time an adapter is used to accommodate a two-hole receptacle, the adapter wire must be attached to a known ground. The third prong shall never be removed from the plug or extension cord.

Double insulation is preferred over grounded tools.

These general practices should be followed when using electric tools:

- » Electric tools shall be operated within their design limitations.
- » When not in use, tools should be stored in a dry place.
- » Electric tools shall not be used in damp or wet locations.
- » Work areas shall be adequately illuminated.
- » Tools shall be held by both handles. If the tool is equipped for a “grip” handle, this handle shall be in place and used (i.e., angle grinder).

*One exception to the use of GFCIs is mag drills. The tool will throw the breaker constantly if used with a GFCI. If using a mag drill overhead, always use a lanyard to keep it from falling should the magnetic contact be broken.*

### *Powered Abrasive-Wheel Tools*

Powered abrasive grinding, cutting, polishing, and wire buffing wheels create special safety problems for guarding because of their many uses in construction.

The manufacturer's recommendations shall be followed when selecting abrasive wheels and disks.



- » Care must be taken to ensure that the disk or wheel will not exceed the abrasive wheel specifications.
- » Wheels and disks shall be replaced when they are worn to less than half the original diameter.
- » Never use an abrasive wheel that is cracked, has chunks of the outer circumference missing from being dropped, or is wet. Cracks will weaken the wheel, chunks will cause it to be out of balance, and water reduces the strength and may cause an out-of-balance condition. All these conditions could cause a wheel to explode on startup.
- » Due to the possibility of a wheel disintegrating (exploding) during startup, the employee should never stand directly in front of the wheel as it accelerates to full operating speed.
- » Portable grinding tools need to be equipped with safety guards to protect workers not only from the moving wheel surface but also from flying fragments in case of breakage.

When using a powered grinder:

- » Always use eye and face protection, including a face shield
- » Turn off the power when not in use
- » Never clamp a handheld grinder in a vise
- » Use hearing protection, if applicable to the task and duration of work

### *Pneumatic Tools*

Pneumatic tools are powered by compressed air and include chippers, drills, hammers, and sanders.

Pneumatic tools that shoot nails, rivets, or staples and operate at pressures more than 100 pounds per square inch shall be equipped with a special device to keep fasteners from being ejected unless the muzzle is pressed against the work surface.

Eye and face protection (face shield over safety glasses) is required for all employees working with pneumatic tools.

Working with noisy tools such as jackhammers requires proper, effective use of hearing protection. This may include the use of both ear inserts and earmuffs to reduce the noise level to below permissible exposure levels.

When using pneumatic tools, employees must check to see that they are fastened securely to the hose to prevent them from becoming disconnected. A wire or positive locking device attaching the air hose to the tool is mandatory.

Airless spray guns that atomize paint fluids at high pressures (1,000 pounds or more per square inch) shall be equipped with automatic or visual manual safety devices that will prevent pulling the trigger until the safety device is manually released.

If an air hose is more than one-half inch in diameter, a safety excess flow valve must be installed at the source of the air supply to shut off the air automatically in case the hose breaks.

A safety clip or retainer shall be installed to prevent attachments, such as chisels on a chipping hammer, from being unintentionally shot from the barrel.

Screens shall be set up to protect nearby workers from being struck by flying fragments around chippers, riveting guns, staplers, jackhammers or air drills.



Compressed air guns shall never be pointed toward anyone. Users shall never “dead-end” it against themselves or anyone else.

Workers operating a jackhammer must wear safety glasses and steel toe boots/shoes that protect against injury if the hammer slips or falls. A face shield shall be worn over safety glasses.

### *Liquid-Fuel Tools*

- » Liquid-fuel tools are often prohibited on projects. Be certain that you are aware of any restrictions of use.
- » They include post-hole diggers, chain saws, chop saws and so forth—require the use of hearing protection, face and eye protection and the use of steel toe shoes/boots. Metatarsal protection should be considered.
- » Fuel cans shall be the approved safety-can type. Fuel storage shall be in areas free from ignition sources.
- » Before refueling, the engine must be off and cool to prevent accidental ignition of flammable vapors.
- » If a fuel-powered tool is used inside a closed area, effective ventilation and personal protective equipment are needed to avoid breathing carbon monoxide. Air monitoring may be necessary. Fire extinguishers shall be available in the area.

### *Powder-Actuated Tools*

Powder-actuated tools operate like a loaded gun and should be treated with the same respect and precautions. Employees using this type of tool must be specially trained by the manufacturer and must have a card in their possession which validates their training. These tools are often prohibited or restricted as to when they may be used on projects. Be certain that you are aware of any restrictions of use.

- » These tools shall not be used in an explosive or flammable atmosphere.
- » Before using the tool, the worker shall inspect it to determine that it is clean, that all moving parts operate freely and that the barrel is free from obstructions.
- » Warning signs shall be posted within 50 ft. of the area where powder-actuated tools are to be used.
- » Hearing protection shall be required.
- » Eye protection is required (safety glasses with side shields).
- » Face shields shall be required to protect the employee from flying debris caused by spalling.
- » If it is anticipated that the employee will be firing more than 10 shots, vibratory or shock-reducing gloves are mandatory to prevent hand and wrist nerve damage from the concussion of the shots.

Before activating the tool:

- » Check angle of entry.
- » Check background. Determine what would be struck if the “projectile” misses or goes through the base material without stopping. Backing material shall be used to prevent this type of “pass through.”
- » Tools shall not be loaded with powder or projectile until immediately prior to the intended firing.
- » Loaded tools shall not be left unattended.
- » Fasteners shall not be driven into very hard or brittle materials.
- » No fastener shall be driven into a spalled area (i.e., no re-shoots into the same hole).



## HAZARD COMMUNICATION

This Hazard Communication Program ensures that all employees are aware of the health hazards associated with chemicals and hazardous substances used at our project sites and that all employees have been trained in procedures for safely working with hazardous substances.

This program complies with the requirements of OSHA 1926.1200 – Construction Standard Subpart Z. A copy of the written Alberici Hazard Communication Program will be available to every project.

### Program Coordinator Responsibilities

Company safety directors are designated as the Alberici hazard communication program coordinators (HCPC). Every project site will also have a project site coordinator. The project site coordinator will be responsible for presenting the material and training in English and alternate languages (if applicable by location or work population) by:

- » Notifying each site contractor about the applicability of this procedure
- » Advising and verifying to contractors on the project site that a hazardous chemical will be introduced or is present on the site
- » Providing Safety Data Sheets (SDSs) to employees upon request
- » Ensuring that all employees have been trained in the proper use of hazardous substances and chemicals during project tasks
- » Verifying that all employees have been informed of the hazards prior to working with hazardous substances or chemicals on the project site
- » Verifying that containers are clearly labeled as to contents, appropriate warnings are noted, and the names and addresses of manufacturers are identified

### Inventories of Hazardous Chemicals and Substances

A [list of hazardous chemicals and substances](#) used at the project site will be submitted to the general contractor, and the list will be updated as the project progresses. A copy of this list is available upon request.

The HCPC, project manager, or safety representative will request and maintain a copy of all subcontractors' SDSs, which will be available to the owner-client and all affected personnel.

Subcontractors must provide an SDS to Alberici's project manager or safety manager before introducing a hazardous chemical to a project site. If a subcontractor fails to do so, the work will be immediately stopped until SDSs are reviewed and made available to site personnel.

The SDS log and SDSs of hazardous chemicals shall be retained for a minimum of 30 years upon closeout of a project.

### Hazard Determination Procedure

We will rely on manufacturers' labels or SDSs to evaluate the various hazards of chemicals used on the project site. The HCPC or safety representative will accept the information provided on the SDS.

If information is missing or the manufacturer fails to supply an SDS, the HCPC will request it from the supplier in writing. SDSs should be current and information up to date. If a SDS submitted is over three years old, contact the manufacturer to determine if a revision has been made.



## Labels and Other Forms of Warnings

Labels are our primary means of warning employees about the products. All containers received for use should be clearly labeled as to content, appropriate warnings should be noted, and the names and addresses of manufacturers should be listed. Examples of labeling systems must be incorporated into this program and shown to all project employees during their training.

The project site coordinator is responsible for ensuring that all containers are labeled. Labels are not to be removed from any container or defaced in any manner. If a label is missing or illegible, the project site coordinator must be notified immediately. The SDS can serve as a temporary label that will assist employees in identifying the chemical involved. If a material is transferred from the primary container to another container, the secondary container shall be labeled as to its contents.

## Safety Data Sheets (SDSs)

Alberici's SDSs are maintained via VelocityEHS (msdsonline via theCommons). Copies of the SDSs for hazardous chemicals used on a specific project site may be obtained by requesting them from the HCPC.

The SDS is the primary source of information. While all SDSs may not be uniform in appearance, they must contain the same information:

- » Identification
- » Hazard identification
- » Composition/information on ingredients
- » First aid measures
- » Firefighting measures
- » Accidental release measures
- » Handling and storage
- » Exposure controls and personal protection
- » Physical and chemical properties
- » Stability and reactivity
- » Toxicological information
- » Ecological information
- » Disposal considerations
- » Transport information
- » Regulatory information
- » Other information

## Personal Protective Equipment (PPE)

PPE suitable for chemical hazards will be maintained on the project site as long as the hazard exists. All PPE will be available, at no cost, to any employee exposed to hazardous materials.

## Emergency Response

An emergency response plan shall be prepared if hazardous materials are on site in quantities that require an emergency/evacuation plan. The plan shall be prepared before the materials arrive on site



and will be communicated to all affected employees. The plan shall be updated as needed to ensure it is current.

All incidents of overexposure, spills, or leaks of any hazardous material will be reported immediately. Proper spill containment and emergency care for those exposed must be provided immediately.

### **Methods to Inform Contractors about Hazards**

Information on hazardous chemicals known to be present will be exchanged with our owner-clients and other employers. Subcontractor responsibilities include:

- » A list of chemicals on the project site
- » Submission of all SDSs to Alberici prior to the use of the hazardous chemical or substance
- » Must have all containers labeled with OSHA-required information or the container contents
- » Full responsibility for training their employees in their own hazard communication program
- » Maintaining their own hazard communication records
- » Complying fully with the federal or state hazard communication program



## HEARING CONSERVATION PROGRAM

To ensure compliance with the Federal Occupational Safety and Health Act (OSHA) of 1970, specifically 29 CFR 1926.52, titled “Occupational Noise Exposure,” Alberici will administer a continuing, effective hearing conservation program. (Michigan OSHA Standard is found under Part 680.) The program will be used whenever employee noise exposures are equal to or in excess of the eight-hour time-weighted average sound level (TWA) of 85 decibels (measured on the “A” scale). The hearing conservation program implemented by Alberici consists of seven basic components:

- » Noise exposure monitoring
- » Engineering and administrative controls
- » Use of hearing protection devices
- » Audiometric evaluation
- » Education and motivation
- » Recordkeeping
- » Program evaluation

### Noise Exposure Monitoring

Project management will notify the Safety Department if they suspect project noise levels will approach or exceed the level of 85 decibels over an eight-hour period per day.

The Safety Department will implement a project-specific noise level monitoring program. The monitoring program will determine the level of employee exposure. If initial monitoring indicates levels are safely below the time-weighted average (TWA), there is no need to implement a hearing conservation program. If the noise levels are at or near 85 decibels, the hearing conservation program must be initiated. Workers exposed at 85 decibels or above will immediately be provided with, and be expected to wear, hearing protection until the noise levels can be reduced by engineering controls. If noise levels exceed 90 dBA, hearing protection will be mandatory.

Monitoring will be repeated whenever there is a change in equipment, the work in progress, or other conditions that may affect employees' exposure to noise.

Under no circumstances should an employee be exposed to noises greater than 140 dBA without the use of hearing protection.

### Engineering and Administrative Controls

The use of engineering controls should be the first method to reduce or eliminate noise exposure. To ensure results, Alberici will specify low noise levels when purchasing new equipment.

Equipment operators play an important role in this program as they should be trained to advise the project management team and the Safety Department when they suspect noise levels are at or near 85 dBA. Equipment operators will use the equipment in a way to keep the noise level as low as possible.

To control noise administratively, it may be necessary to limit the number of employees in an area when the noise levels are high or to rotate personnel in and out of high noise exposure areas.



## Use of Hearing Protection Devices

In the absence of feasible engineering or administrative controls, Alberici shall provide all employees in the hearing conservation program with hearing protection devices. Several different types of protectors will be made available for employees.

Employees will be trained in how to reduce their exposure to noise; how noise affects their hearing; the need for hearing protection; how to wear their hearing protectors correctly at all times; when to seek replacements; encouraging coworkers to use these devices; and communicating problems to their supervisor.

When employees are exposed to the 90 decibels level, hearing protectors are not optional. OSHA requires Alberici to enforce their consistent use by employees.

## Audiometric Evaluation

Audiometric tests will be made available to employees whose exposures equal or exceed the eight-hour TWA of 85 decibels, and if noise levels cannot be reduced by engineering or PPE as defined by the AHA. Within six months of an employee's continuous exposure at or above the action level not resolved by engineering practices, administrative controls, or PPE, project management shall require that the employee establish a valid baseline audiogram against which future audiograms can be compared.

Testing to establish a baseline audiogram shall be preceded by at least 14 hours without exposure to workplace noise. Hearing protection may be used to meet the requirement. The cost of audiometric testing is the company's responsibility. Employees shall also be notified to avoid high levels of noise by wearing proper PPE. If a threshold shift occurs, the use of hearing protection shall be re-evaluated and/or refitted and, if necessary, a medical evaluation may be required. When a mobile van is used, the baseline shall be established within one year. This test will be repeated at least annually if the employee remains exposed to the noise levels that are not controlled by PPE or engineering methods.

## Education and Motivation

Alberici believes that education and motivation are essential components to the success of our hearing conservation program. Education and motivation sessions are valuable for both the management team and employees so they will understand that a successful hearing conservation program takes commitment, communication, and cooperation.

Employees exposed at or above 85 decibels will be trained at least annually in the following:

- » Effects of noise on hearing
- » Purpose of hearing protectors
- » Advantages, disadvantages, and attenuation of various types of hearing protectors
- » Selection, care, and fitting of various types of hearing protectors
- » Purpose of audiometric testing and test results

## Recordkeeping

Records to be retained include:

- » **Noise Exposure Measurements:** Records of noise exposure measurements must be retained for at least 2 years. These records are used to determine whether employees are exposed to noise at or above the action level (85 dB over an 8-hour time-weighted average).



- » **Audiometric Test Records:** Records of audiometric tests must be maintained for the duration of the affected employee's employment. These records should include the employee's name, job classification, date of the test, examiner's name, date of the last acoustic calibration of the audiometer, the employee's most recent noise exposure assessment, and audiometric test results.
- » **Training Records:** Employers should keep records of employee training related to hearing conservation. While OSHA does not specify a retention period for training records, it's good practice to maintain these records for the duration of employment to demonstrate compliance.

Employees shall have the right to inquire about their hearing status and access their records at any time they desire.

### **Program Evaluation**

To determine the extent to which our hearing conservation program is working, Alberici will perform a thorough evaluation of all the hearing conservation program components.

In completing this task, Alberici will evaluate the audiometric data. This approach will consist of evaluating the results of audiometric tests, both for individuals and for groups of noise-exposed employees.

As with many other aspects of the hearing conservation program, it is the employee's responsibility to provide feedback to safety personnel and the management team on the program's merits and shortcomings.



## HEAT ILLNESS AWARENESS AND PREVENTION

This heat stress awareness and prevention program has been established to combat heat-related illnesses, injuries, and fatalities on our projects.

Heat illness can take on many levels of severity from minor rashes to the most serious – heat stroke. Heat cramps and heat exhaustion are less serious but still significant heat illnesses. It is important to know that heat illness can take place whether our work is indoors or outdoors. We may think of heat illness more when we are working outside in the hot sun, but circumstances inside facilities can also cause heat-related illnesses.

### Project Controls

Even at a heat index of less than 60° Fahrenheit, there may be some risk of heat-related illness if tasks involve the use of personal protective equipment (PPE), layers of clothing, and/or extreme physical exertion. Project teams should always consider climate and temperature as well as other meteorological factors when planning work. Budgeting for control measures, consideration of schedule, and safe work factors are part of management of our projects. When working outdoors, be conscientious of the type of clothing that workers wear and educate the workforce. Lightweight, light-colored clothing is better than heavy, dark attire. Long-sleeved shirts may seem contradictory in the heat and sun, but they protect workers from sun exposure and sunburn and stay moist and act to cool when one begins to sweat. Thin, cotton shirts are preferred over thicker materials and synthetic blends. Additional layers of clothing, like vests, may increase the risk for heat illness. Unless vests are necessary for visibility, traffic control, etc., consider eliminating them on a case-by-case and day-by-day basis.

Indoor workers may also be exposed to high temperatures. Engineering or administrative controls should be implemented to reduce exposure to heat illness.

### Identifying and Initiating Treatment for Heat Illnesses

- » Heat rash is the most common problem in hot work environments. It is caused by sweating and looks like small pimples or blisters. It is most common on the neck, upper chest, groin, under the breasts, and in elbow creases. The rash area should be kept dry. Powder may be applied to increase comfort. Ointments or creams that keep the skin warm or moist may worsen the rash. The best treatment for heat rash is to provide a cooler, less humid work environment.
- » Heat cramps are muscle pain and spasms caused by the loss of body salts and fluid during sweating. Workers can prevent or lessen the effects of heat cramps by drinking water and/or carbohydrate/electrolyte replacement liquids such as sports drinks every 15 to 20 minutes. The use of caffeinated beverages and energy drinks may worsen the problem.
- » Heat exhaustion and heat stroke are the most serious of the heat-related illnesses we are exposed to. Every person on a project, including project leaders and first response teams, should be trained to recognize symptoms and initiate treatment. Heat exhaustion and heat stroke are true medical emergencies and once initial first aid treatment takes place, trained medical providers should be contacted and take over.
- » Heat exhaustion signs and symptoms include headache, nausea, dizziness, weakness, irritability, confusion, thirst, heavy sweating, and a body temperature that may exceed 104° Fahrenheit. Some workers never experience heat rashes or cramps. The first sign of heat illness can be heat exhaustion. Treatment includes moving the worker into shade and cooling the worker with cold compresses to the head, neck, and face. Encourage cool water intake. Workers with heat exhaustion should be taken to a clinic for evaluation and possible treatment. If symptoms worsen,



seek immediate medical attention and call 911.

- » Heat stroke occurs when the body's core temperature-regulating systems in the brain fail, and core body temperature rises to critical levels – 104° Fahrenheit or higher. This is a medical emergency that may result in death. Signs of heat stroke include confusion, loss of consciousness, and seizures. Persons experiencing heat stroke have extremely high core body temperature (undiagnosable using traditional oral or skin thermometers) and may stop sweating as their bodies shut down. If a worker shows signs of possible heat stroke, get medical help immediately and call 911. When possible, move the worker to a shady, cool area and remove as much clothing as possible until medical help arrives. Wet the worker with cool water and circulate the air to speed cooling. Place cold, wet cloths or towels or ice over the person's body or soak their clothing with cold water.

### Occupational Factors

Construction is one of at least 70 occupations identified by OSHA as having potential heat illness exposures. It's important to know that heat illnesses do not always occur in very hot environments. Sudden, early-season temperature spikes, workers transferring into projects located in warm or humid climates from cool, dry locations, and not having an opportunity to get used to the heat (acclimatization) can trigger heat-related illnesses. Some factors to consider include:

- » High temperatures and humidity
- » Low fluid consumption
- » Work in direct sun exposure or extreme heat
- » Limited air movement
- » Use of bulky protective clothing and equipment
- » Required PPE such as helmets, vests, and gloves

### Program Guidelines

The program includes the following components:

1. Administrators
  - a. Alberici corporate safety directors will administer and oversee the heat illness prevention program, and an individual at each project location will be identified to oversee the heat illness prevention program on a site-specific basis. In the absence of a safety representative, the project manager must identify the program administrator.
  - b. This individual must have training in and an awareness of hazards, physiological responses to heat, and management of controls.
2. Hazard identification
  - a. Being able to recognize heat hazards and the risk of heat illness due to high temperature, humidity, sunlight, and other thermal exposures including work demands, clothing, PPE requirements, and personal risk factors
  - b. Identification tools can include OSHA-NIOSH's Heat Index Smartphone App, Wet Bulb Globe Thermometer (WBGT), and National Weather Service Heat Index.
    - i. Projects can use the OSHA-NIOSH Heat Index Application to alert workers early in the shift of the possibility of a high heat and humidity day and to begin precautions.
    - ii. The WBGT measures heat stress in direct sunlight and considers temperature, humidity, wind speed, sun, and cloud cover. As it can be complicated to understand, WBGT measurements should be conducted by someone trained to do so.
3. Access to water, rest, and shade as needed and based on heat indices for the day
  - a. Ensure that cool drinking water is available and easily accessible. Educate workers to avoid beverages that can lead to dehydration. Energy drinks containing high levels of sugar and



- caffeine and other caffeinated beverages should be limited.
- b. Encourage workers to drink a liter of water per hour or about one cup of water every 15 minutes. The use of “salt pills” is unnecessary and may worsen preexisting health issues.
  - c. Provide fully shaded or air-conditioned areas for rest and cooldowns when possible. If a worker indicates that they need to get out of the heat, they must be allowed to do so as often as needed. If it becomes obvious that workers are exhausted from the sun and heat, consider shutting down the project for the remainder of the shift and reevaluate the future schedule.
  - d. Be prepared to identify the levels of heat each day and communicate at the start of shift. A heat index of 80° Fahrenheit or higher or notification by the National Weather Service that high heat watches and warnings are in place are significant and require action. Repeat the communication regarding heat levels throughout day. If circumstances change, stop work and stand down the crews to remind them of weather and heat conditions.
4. Acclimatization
- a. Acclimatization is the physical change that allows the body to build tolerance to working in the heat (or cold). It occurs by gradually increasing workloads and exposure and taking frequent breaks for water or rest in the shade.
  - b. Acclimatization can take two weeks or longer depending on factors related to the individual – medical conditions, age, weight, medications, or environment.
  - c. Adjustments to the normal workload for new or experienced workers should be considered and made for all workers (e.g., day 1 – 20%, day 2 – 40%, day 3 – 60% up to 100% for newly hired workers. For experienced workers, acclimatization may be 50% - day 1, 60% day 2, 80% day three up to 100%). Projects should plan accordingly to acclimatize newly hired workers when work in hot environments is anticipated.
5. Modified work schedules
- a. Work may need to be altered to allow for a reduction in worker exposure to heat. Examples include:
    - i. Reschedule all non-essential outdoor work for days with a reduced heat index
    - ii. Schedule more physically demanding work during cooler parts of the day
    - iii. Schedule less demanding physical work during warmer parts of the day
    - iv. Rotate workers
    - v. Split shifts
    - vi. Add extra workers
    - vii. Work/rest cycles using established industry guidelines
    - viii. Stop work if essential control measures are inadequate or unavailable when the risk of heat illness is very high
6. Training
- a. Training must be conducted in languages that workers understand and include the following:
    - i. Information on health effects of heat
    - ii. Symptoms of heat illness
    - iii. How and when to respond to symptoms
    - iv. How to prevent heat illness.
    - v. How to evaluate impact of heat on workloads of increasing intensity
  - b. Train forepersons and supervisors on how to identify signs and symptoms of heat illness and how to manage crews, including encouraging crews to drink water, take rest breaks, and move to shade when possible.
  - c. Workers must understand that they may not modify PPE (i.e., drill “air holes” into helmets to increase circulation).
7. Monitoring for signs and symptoms of heat illness
- a. Establish a system to report signs and symptoms to improve early detection and action
  - b. If practical, first responders may go from crew to crew to check on workers.



- c. Front-line supervisors should be trained and aware of signs and symptoms of heat stress.
- d. Work partners and crews must watch out for one another.
- 8. Emergency planning and responses
  - a. Establish an emergency plan and communicate it to all supervisors and workers that considers the following:
    - i. What to do when someone is showing signs and symptoms of heat illness
    - ii. Know how to contact emergency help
    - iii. Know how long it will take for emergency help to arrive
    - iv. Identify routes for emergency services and establish guides stationed along the emergency route
    - v. Train workers in first aid and CPR. Always have at least one person per shift who can respond and perform first aid and CPR.
- 9. Buddy system
  - a. Workers should always have a partner who can respond to emergencies in any type of incident.
  - b. Do not partner apprentices with other apprentices.
- 10. Tools and materials
  - a. Each project should assess their individual needs. The following are recommended for all projects:
    - i. A cooling shack or tent where workers can take additional rest periods and where they can find cool water and ice
    - ii. Provide cooling towels/wraps – available from safety supply stores. The towels are made with pellets that swell when they absorb water and can be used as neck or head wraps.
    - iii. Provide sun brims for hard hats and helmet.
    - iv. Industrial size fans to circulate air when performing work or during rest periods
    - v. Provide adequate amounts of potable water for workers to drink throughout the day. Plan on no less than one half gallon of water per person per day, or eight 8-ounce glasses (provide markers if workers use 16 ounce or ½ liter containers to prevent waste).
  - b. Additionally, projects may consider other options:
    - i. Cooling vests or jackets that circulate cool water throughout the garment
    - ii. Ice pop breaks in the AM and PM
    - iii. Resupplying ice to water containers and coolers periodically during the shift
  - c. Every project should have the following:
    - i. Access to the weather forecast and daily awareness of heat indices. The OSHA-NIOSH heat index app is available for Apple and Android devices.
    - ii. Access to 911. Check to ensure that, regardless of where you are working on a project, you have cellular service in case you need to call for emergencies.
    - iii. Towels and wash clothes to be used in situations of potential heat exhaustion or heat stroke (shop rags are acceptable alternatives)
    - iv. Access to cool (running) water via faucet or hose
    - v. Means to get workers to cool, shaded areas quickly

### When should work stop?

Although there are no specific guidelines, and every worker has different tolerances to heat, it's key to have a buddy system in place for workers to identify heat illness in coworkers. Implementing work-rest periods is essential up to 30 minutes of work and 30 minutes of break. Beyond that point, it may be best to stop work and send people home. Discuss with your entire team and include trade partners and clients to determine whether this is a feasible option.



<b>WBGT<sub>clo</sub> Work</b>	<b>WBGT<sub>clo</sub> Rest</b>	<b>Acclimatized Workers Work: Minutes</b>	<b>Unacclimatized Workers Work: Minutes</b>
70	70	60	60
80	80	60	20
80	70	60	40
85	85	25	5
85	80	35	15
85	70	45	30
87	87	15	0
87	80	30	15
87*	70	40	30

“Work: Minutes” are rounded to the nearest 5 minutes.

<b>Adj. Heat Index</b>	<b>Est. WBGT</b>	<b>Adj. Heat Index</b>	<b>Est. WBGT</b>	<b>Adj. Heat Index</b>	<b>Est. WBGT</b>
80	70	94	79	108	86
81	71	95	80	109	86
82	71	96	80	110	87
83	72	97	81	111	87
84	73	98	81	112	88
85	73	99	82	113	88
86	74	100	82	114	88
87	75	101	83	115	89
88	75	102	83	116	89
89	76	103	84	117	89
90	77	104	84	118	89
91	77	105	85	119	90
92	78	106	85	120	90
93	79	107	86	121	90

Adapted from Bernard and Iheanacho (2015).

The following graph will aid projects in determining whether work should be stopped.

How to use the chart (using only heat and humidity – WBGT is more accurate):

1. Go to [www.wrh.noaa.gov/psr](http://www.wrh.noaa.gov/psr) and select your location to obtain the local temperature in Fahrenheit and relative humidity (RH).
2. Find the corresponding temperature and RH on the chart. The box that connects the two numbers will contain the current heat index (HI). Notice the color of this box.
3. Find the box with the same color and read about the health effects of the HI and safety recommendations to follow.



The following graph will aid projects in determining whether work should be stopped.

How to use the chart (using only heat and humidity – WBGT is more accurate):

1. Go to [www.wrh.noaa.gov/psr](http://www.wrh.noaa.gov/psr) and select your location to obtain the local temperature in Fahrenheit and relative humidity (RH).
2. Find the corresponding temperature and RH on the chart. The box that connects the two numbers will contain the current heat index (HI). Notice the color of this box.
3. Find the box with the same color and read about the health effects of the HI and safety recommendations to follow.

		RELATIVE HUMIDITY (%)																				
°F	0	5	10	15	20	25	30	35	40	45	50	55	60	65	70	75	80	85	90	95	100	
140	125																					
135	120	128																				
130	117	122	131																			
125	111	116	123	131	141																	
120	107	111	116	123	130	139	148															
115	103	107	111	115	120	127	135	143	151													
110	99	102	105	108	112	117	123	130	137	143	150											
105	95	97	100	102	105	109	113	118	123	129	135	142	149									
100	91	93	95	97	99	101	104	107	110	115	120	125	132	138	144							
95	87	88	90	91	93	94	96	98	101	104	107	110	114	119	124	130	136					
90	83	84	85	86	87	88	90	91	93	95	96	98	100	102	106	109	113	117	122			
85	78	79	80	81	82	83	84	85	86	87	88	89	90	91	93	95	97	99	102	105	108	
80	73	74	75	76	77	77	78	79	79	80	81	81	82	83	85	86	86	87	88	89	91	
75	69	69	70	71	72	72	73	73	74	74	75	75	76	76	77	77	78	78	79	79	80	
70	64	64	65	65	66	66	67	67	68	68	69	69	70	70	70	71	71	71	71	71	71	72

<p>Heat Index: 130+ degrees F</p>	<p>Health Effect: Heatstroke/sunstroke is highly likely with continued exposure Recommendations: Avoid strenuous outdoor activity. Stay indoors in an air conditioned facility. Stay well-hydrated. Drink 10 gulps every 20 minutes. Check on your family, friends, and neighbors.</p>
<p>Heat Index: 105-129 degrees F</p>	<p>Health Effect: Sunstroke, heat cramps and heat exhaustion are likely. Heat stroke is possible with prolonged exposure and/or physical activity Recommendations: Avoid strenuous outdoor activity; Stay indoors in an air conditioned facility; Stay well-hydrated. Drink 10 gulps every 20 minutes.</p>
<p>Heat Index: 90-104 degrees F</p>	<p>Health Effect: Sunstroke, heat cramps and heat exhaustion are possible with prolonged exposure and/or physical activity Recommendations: Limit strenuous outdoor activity; Limit your time outdoors; Stay well-hydrated. Drink 10 gulps every 20 minutes.</p>
<p>Heat Index: 80-89 degrees F</p>	<p>Heat Effect: Fatigue is possible with prolonged exposure and/or physical activity Recommendations: Limit your time outdoors; Stay well-hydrated. Drink 10 gulps every 20 minutes.</p>



## Indoor Work Considerations

Indoor workplaces may be cooled by using air conditioning or increasing the ventilation, provided that the outside air is cooler than inside. Other engineering controls include:

- » Providing reflective shields to redirect radiant heat
- » Insulating hot surfaces
- » Decreasing water vapor pressure
- » Use of fans

In all situations, an industrial hygienist or occupational physician can be consulted to make recommendations for reducing heat exposure.

Be aware that if a compliance or site visit by a compliance assistance specialist from OSHA occurs, they will be looking for the following information based on the OSHA Standard Directive (The directive can be accessed from the OSHA website doing the following search: CPL\_03-00-24.pdf):

- » OSHA 300 Logs and 301 Incident Reports for any entries indicating heat-related illnesses
- » Any records of heat-related emergency room visits and/or ambulance transport, even if hospitalizations did not occur (this may require the use of a Medical Access Order)
- » They will interview workers for symptoms of headache, dizziness, fainting, dehydration, or other conditions that may indicate heat-related illnesses, including both new workers and any workers who have recently returned to work.
- » They will review this heat illness and injury program addressing heat exposure and consider the following:
  - Is there a written program?
  - How were ambient temperatures and levels of work exertion measured at the worksite?
  - Is there unlimited cool water that was easily accessible to the workers?
  - Do employers require additional breaks for hydration?
  - Are there scheduled rest breaks?
  - Is there access to a shaded area?
  - Is there time for acclimatization of new and returning workers?
  - Is a “buddy” system in place on hot days?
  - Are administrative controls used (earlier start times, and employee/job rotation) to limit heat exposures?
  - Is training on heat illness signs, how to report signs and symptoms, first aid, how to contact emergency personnel, prevention, and the importance of hydration provided at the time of orientation and seasonally?

For questions related to this program, please contact your safety representative.



## References

[www.osha.gov/heat](http://www.osha.gov/heat)  
[www.cdc.gov/niosh/topics/heatstress](http://www.cdc.gov/niosh/topics/heatstress)  
[www.cpwr.com/search-results/?search\\_txt=heat](http://www.cpwr.com/search-results/?search_txt=heat)  
[www.noaa.gov/stories/excessive-heat-silent-killer](http://www.noaa.gov/stories/excessive-heat-silent-killer)  
[www.wpc.ncep.noaa.gov/html/heatindex.shtml](http://www.wpc.ncep.noaa.gov/html/heatindex.shtml)  
[www.assp.org/news-and-articles](http://www.assp.org/news-and-articles)  
[www.dir.ca.gov/dosh/heatillnessinfo.html](http://www.dir.ca.gov/dosh/heatillnessinfo.html)  
[www.dir.ca.gov/dosh/etools/08-006/](http://www.dir.ca.gov/dosh/etools/08-006/)  
[www.osha.oregon.gov/Pages/search-results.aspx?q=heat](http://www.osha.oregon.gov/Pages/search-results.aspx?q=heat)

ANSI/A10.50 - Standard for Heat Stress Management in Construction and Demolition Operations (2026)

Alberici: Heat Illness Awareness Training (.ppt)



## HELICOPTER SAFETY PROCEDURE

The following helicopter procedure is a partial list of general regulations and safe practices that shall apply to all helicopter work. Each owner may have specific requirements that must be met before performing any helicopter lifts at a project site.

Review the requirements prior to establishing a helicopter lift ([Helicopter Safety Forms](#)).

### Handling of Workloads

- » Helicopter operations must comply with all applicable regulations of the Federal Aviation Administration (FAA).
- » No unauthorized person shall be allowed to approach within 50 feet of the helicopter when the rotor blades are in motion. All involved employees shall remain in full view of the pilot and remain in a crouched position.
- » Employees shall avoid the area from the cockpit of the cabin rearward unless authorized by the helicopter operator to work there.
- » Goggles and helmet chinstraps are required for all personnel participating in a lift activity. Loose clothing shall not be worn. Hearing protection for personnel within 200 feet of the helicopter is mandatory.
- » A preflight briefing must be held before each day's operations and shall include the plan of operations for pilot and ground employees. Project management shall inform our employees and other contractors on site of the day's plan of operation. Typically, preliminary notification will take place two weeks before the planned lift and repeated in the days before the lift.
- » Every practical precaution shall be taken to protect employees from flying objects in the rotor downwash. All loose gear within 100 feet of the location where the load is lifted and deposited and all other areas susceptible to rotor downwash shall be secured or removed.
- » Good housekeeping shall be maintained in all helicopter loading and unloading areas.
- » Loads shall be properly slung. Tag lines shall be of a length that will not permit their being drawn up into the rotors. Some helicopter pilots will not perform a lift if tag lines are used. Be certain to clarify before making the lift using a tag line. Pressed sleeve, wedged eyes, or equivalent means shall be used for all freely suspended loads to prevent hand splices from spinning open or cable clamps from loosening.
- » When dust or other conditions reduce visibility, ground personnel shall exercise special caution to keep clear of main and stabilizing rotors.
- » Signal systems between air crew and ground personnel shall be understood and checked in advance of hoisting the load. This requirement applies to either radio or hand signal systems.
- » There shall be constant, reliable communication between the pilot and a designated employee of the ground crew who acts as a signal person during the period of loading and unloading. This signal person shall be distinctly recognizable from other ground personnel.
- » The helicopter operator shall be responsible for the size, weight, and manner in which loads are connected to the helicopter. If for any reason the helicopter operator believes the lift cannot be made safely, the lift shall not be made.
- » When employees are required to perform work under hovering craft, safe means of access shall be provided for employees to reach the hoist line and engage or disengage cargo slings. Employees shall not perform work under a hovering craft except when necessary to hook or unhook loads.



- » The flight path shall be determined by taking an area three times the width of the load being carried or three times the width of the blades. No one shall be allowed to work within the designated area during the time that the helicopter lift is taking place.
- » Barricade tape or barriers shall be installed within the building and grounds to designate the flight path. The contractor representative coordinating the helicopter operation shall identify the flight path on the plant map, designating routes and times. Maps must be posted on bulletin boards and affected departments notified.
- » Discuss rotors building up static and the possible discharge of static electricity from suspended loads. Instruct personnel that the load may be charged. A load ground and personnel wearing rubber gloves may be required. Some helicopter companies use static-free rigging from the helicopter.
- » Ensure that materials being lifted are separated a safe distance to prevent pinching or entrapment when lifting. Material such as stacks must be adequately cribbed to prevent rolling from downwash.
- » Depending on the helicopter model, downwash can tip over adjacent materials, such as roof vents or hoods. Separation distance needs to be coordinated with the helicopter crew.
- » Preplan for medical emergencies. Arrange for standby medical assistance. Ensure that all parties know how to access the staging area and placement points. Notify local police and fire departments of the intended date and time of the lift.
- » Ensure that safety around roof openings and roof edges is properly planned for.
- » If the helicopter is required to remain parked at the plant or construction area overnight, security measures will be discussed with the crew. Security personnel may need to monitor the aircraft throughout the night.
- » FAA 135 requires the helicopter either be inspected within the previous 100 hours of flight time or be on a progressive 25-hour maintenance program. Ensure and document that the inspection has been completed.
- » Verify the pilot has had FAA-required rest time. Also ensure that the pilot will not have been on duty more than 14 hours or have flown more than eight hours in the preceding 24-hour period.

### **Emergency Medical Service Helicopter Flights**

- » If helicopters are required for medical service, arrangements for such flights must be made before the service is needed. The helicopter service is usually familiar with local flight restrictions and can assist in developing a workable plan for service.
- » A landing area will be dedicated and well-marked for medical helicopters only. It will not be used for parking, materials storage, or other purposes.
- » Helicopter flights will be coordinated with the ground ambulance service. In most cases, the ground ambulance will transport the patient to the helicopter, and its crew will assist in loading the person.
- » A test flight will be made prior to actual need to ensure the area is free of obstructions and the ground ambulance can access the area easily.
- » All contractors on site who may use the medical helicopter will be informed of the pickup point and requirements to keep the landing area clear of obstructions.
- » As the project site work progresses, it may be necessary to relocate the landing area. If so, a revision to the landing procedure will be made and all contractors on site informed.



## HOUSEKEEPING

Good housekeeping is essential to accident prevention. Maintaining a project site free of accumulated material and other trash can make the work site much safer and directly affect our relationships with owner-clients and trade partners.

Housekeeping must be planned at the beginning of the job and monitored by supervisors until the job is complete. Housekeeping shall be a part of each individual's daily responsibilities.

If housekeeping on a job is not up to the standard set by Alberici, work may be stopped until it meets the satisfaction of the owner and/or project management team.

### Establishing a Procedure

An organized material storage yard can help minimize hazards. Delivery of materials should be scheduled as needed and adequate storage areas provided. The storage area should be kept free of banding, excess cribbing, and other material. Routine assessments should be conducted regularly.

Storage and parking areas should be assigned early in project planning. Trash receptacles should be maintained in both areas and emptied regularly.

Arrangements for trash pickup will vary by project site. Adequate receptacles should be provided in lunch and break areas, as well as in the work areas. To minimize threat of contamination from improperly discarded trash, trashcans should be provided in areas where drinking water is available. Trash containers for food should have lids to prevent varmint infestation.

### Assign Responsibilities

Everyone is responsible for ensuring that their work area is free from hazards created by their own lack of housekeeping efforts. If the size of the project and the workforce warrant it, a crew should be established to clean up regularly.

In this case, housekeeping duties should be assigned to one or more responsible persons. In some cases, contractors may be responsible for housekeeping on the entire site or for just our area.

Personnel need to be aware that housekeeping is everyone's responsibility, and time should be set aside at the conclusion of the shift to ensure the work area is clean and free from hazards created by poor housekeeping.

### Implement the Program

Weekly project site inspections should include a review of housekeeping conditions. Use the extreme housekeeping methods, document findings, and corrective action plans via Procore or other project communications. Weekly SafeTalk meetings should occasionally have housekeeping as the topic.

Superintendents' meetings held just after the weekly inspections can be used to emphasize the need for improved housekeeping. In most cases, it is beneficial to tour the site with subcontractors and address housekeeping defects.

Housekeeping is part of the daily routine, and cleanup should be a regular procedure.



## LEAD IN CONSTRUCTION

In general, Alberici will never knowingly expose our employees to lead. Some jobs that could cause exposure include steel bridge painting or repair, removing lead-based paint in older homes and buildings, grinding or sandblasting lead paint on metal structures, cutting or removing lead pipe in older buildings, and using lead solder.

Alberici workers could have lead exposures if we do abrasive blasting, welding, cutting, or burning, mostly where lead paint is present. We could also have exposure if we heat some roofing products, clean up around demolition sites where lead dust is present, and similar activities ([Lead Rules Checklist](#)).

For the most part, we would identify lead (primarily paint) and hire an abatement company to conduct the abatement work.

In our homes, we may be inadvertently exposed to lead through drinking water contaminated by old lead pipes, eating fish contaminated by lead in the water, or old and chipping paint in our homes.

### Health Hazards

- » Reproductive/developmental toxicity
  - Women and men of childbearing age should be especially careful about their exposure to lead. Lead can affect men by causing impotence, reduced sperm count, or even sterility. Women must be aware that there could be harm to a fetus.
- » Central nervous system effects
- » Kidney effects
- » Blood effects
- » Acute toxicity effects

Just a little bit of dust on clothing can get spread around your house where children can get exposed. Children exposed to too much lead will suffer brain damage and permanent developmental disabilities. Even low exposures to lead can cause learning and behavior problems. Lead was taken out of household paint and gasoline decades ago because of the concern of children's exposure.

### Signs of Lead Poisoning

Signs and symptoms are difficult to detect. Even people who seem healthy may have high blood levels of lead. Signs and symptoms usually do not appear until dangerous levels have accumulated. Children are much more susceptible.

1. Abdominal pain, vomiting, or constipation
2. Headaches
3. Difficulty thinking, concentrating, or making decisions
4. Loss of appetite and weight loss
5. Pale skin, fatigue, or muscle weakness
6. Slow or delayed growth in children
7. Personality changes, mood swings, and trouble sleeping
8. Seizures or a coma



Work areas where lead is present must have signs such as those below:

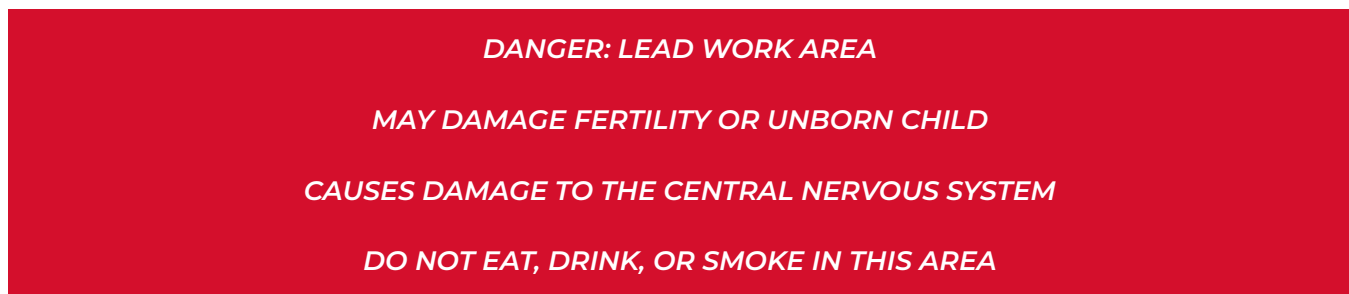

Lead cannot go through your skin. Lead dust can come from sandblasting, grinding, sanding, sawing, or cutting on structures containing lead paint or other lead products or coatings. Lead has no odor even when burned, so you can't tell when you are inhaling it. When lead gets into your body, some of it is excreted quickly. However, ongoing exposure to lead causes it to be stored long-term, and adverse health effects can be long-lasting or permanent.

### **Management of Subcontractors**

Be sure subcontractors performing abatement for Alberici understand they cannot have food or beverages and may not eat or drink in areas where they are exposed to lead above the permissible exposure limit (PEL), regardless of the use of respirators. Other products forbidden from being used include cigarettes, vapes, chewing tobacco, cosmetics, lip balm, and lotions.

In case of exposure above the PEL, employers must provide respiratory protection, medical surveillance, and clean change areas.

Employers must ensure that change areas are equipped with separate storage facilities for protective work clothing and equipment and for street clothes to prevent cross-contamination. Employees may not leave the workplace wearing any protective clothing or equipment that is required to be worn during the work shift.

If possible, shower areas must be available for employees whose airborne exposure to lead is above the PEL. Employees must shower at the end of the work shift with an adequate supply of cleansing agents and towels that are provided by their employers.

Employers must provide lunchroom facilities or eating areas for employees whose airborne exposure to lead is above the PEL.

Employers must ensure that lunchroom facilities or eating areas are as free as practicable from lead contamination and are readily accessible to employees.

Employees must wash their hands and faces prior to eating, drinking, smoking, or applying cosmetics. They may not enter lunchroom facilities or eating areas with protective work clothing or equipment unless surface lead dust has been removed by vacuuming, downdraft booth, or other cleaning method that limits dispersion of lead dust.

Employers must provide adequate handwashing facilities for employees exposed to lead. Where showers are not provided, employees are required to wash their hands and faces at the end of the work shift.



### **Project Responsibilities**

In any AHA/PTP we receive, a description of each activity in which lead is emitted must be included; e.g., equipment used, material involved, controls in place, crew size, employee job responsibilities, operating procedures, maintenance practices, a description of the specific means that will be employed to achieve compliance, and, where engineering controls are required, engineering plans and studies used to determine methods selected for controlling exposure to lead.



## LOCKOUT PROCEDURE

Lockout places equipment and systems in a **zero energy state** whenever a person could be exposed to harm from that energy source. Lockout provides maximum protection to all equipment and to all people who are working on or around equipment powered by an energizing source such as electricity, water, air, or steam.

### Definitions

The term “lockout” shall mean tagging and locking or disconnecting equipment in such a way that it cannot be energized without the lock being removed.

- » **Electrical lockout** will mean the breaking of the circuit by locking the circuit breaker, disconnect switch, or receptacle plug-in type disconnect on the electrical supply line.
  - Disconnecting, taping, and danger-tagging the main lead wires at the breaker by a qualified electrician will be considered a lockout.
- » **Non-electrical lockout** will be made on equipment that is powered by energizing sources such as water, air, and steam by chaining off the source valve, placing a lock and tag on it, and bleeding off any pressure before working on it.
- » **Safety lock** is a lock such as manufactured by Wilson-Bohannon, American, or Master Lock that is uniquely identifiable and uniquely keyed and used for the purpose of locking out energized equipment. Each lock will be supplied with only one key. Under no circumstances should a second key be kept on the project site “in case” the original key is misplaced. If the original key cannot be located, then the lock must be cut off using prescribed criteria. Safety locks are used in conjunction with tags and the lock box and sign-in sheet.
- » **Lockout box (lockbox)** is a box designated to hold safety lockout keys from specific designated equipment locked out by an operator or operators for the purpose of multiple lockouts. The lockout box will be used with a check-in, check-out sheet signed by personnel who apply their lock to the lockbox.

### Responsibilities

- » **Individual:** Every individual who works on or around equipment that can be energized by any means and has exposed parts that can be activated is responsible for personally locking and tagging the equipment using their assigned, uniquely keyed lock. In no case will the lockout by one individual suffice or be considered a lockout for another person. In no case should anyone sign in or sign out another person on the lockout sign-in sheet.
  - 1 person = 1 lock and tag                      2 persons = 2 locks and tags
- » **Management:** Supervisors must review the lockout procedure with each new employee before they start work. The supervisor will demonstrate the procedure to the employee. The employee will then demonstrate to the supervisor their competency in how to perform the lockout. Periodically (at least every six months), the supervisor will review the lockout procedure with employees.
- » Each employee will be issued a safety lock and tags by their supervisor before they begin working in and around energized systems. Replacement or additional locks and tags are available from the supervisor. Tags should be substantial enough to hold up during heavy construction periods.
- » The Safety Department will provide guidance when questions or unusual conditions arise. Additionally, the Safety Department will monitor forcible lockout removal to prevent its misuse.
- » Project engineer is responsible for ensuring that subcontractors’ employees shall be advised of



and comply with the owner’s safety procedures regarding lockout.

- » Facility production staff is responsible for preparing equipment that is energized to be worked on.

Absolute compliance to this procedure is a must. Failure to comply could result in severe injury to someone or damage to equipment—or even a plant disaster.

*Any unauthorized person who removes a safety lock and/or danger (lockout) tag from a piece of equipment or piping and operates or attempts to operate is subject to disciplinary action.*

### Procedure for Lockout

- » This procedure establishes a lockout practice for securing machinery and equipment during periods of construction, maintenance, or repair. It is essential that all contractors are consistent with their lockout procedures to ensure the safety of all employees. A lockout procedure renders inoperative electrical systems, pumps, pipelines, valves, and all other such energy systems that may accidentally be energized or started up while employees are exposed to injury.
- » Contractors and subcontractors will administer their own lockout program and coordinate with others. All locks and applicable tags will be issued by the contractor’s or subcontractor’s supervisors to their own employees, and a log will be kept. Alberici shall keep a lockout log on each project site (per the form in this section) for all work we perform. In this manner, project supervisors are kept informed of locks put in place and their removal.
- » Each person shall have his or her own lock on any system and at any time that person feels the need to be in control of the lockout. No one may remove someone else’s lock except in rare, exceptional, and well-documented instances. Approval for removal of another person’s lock is only granted by the project manager or the Safety Department. Owners also have specific protocols for forcible lock removal. Each person should be aware of the identification number or other identifying mark on his or her own locks so they can be identified at the time of removal. Workers should use their lockout tag to personally identify the lock they apply onto a system.
- » For energy systems being worked on by multiple persons, crafts, or contractors, a multilockout clamp (hasp) is to be used, or the supervisor control keys can be secured in a lockbox with locks from each tradesperson protecting the supervisor’s lock from being removed until all other locks are off the box. Each craft or subcontractor shall put its own system tag and lock on the box also.
- » The required procedure is to log it in, isolate the system, lock it out, tag it out, try it out.

Log It In	Put all the information on the log to identify the system to be locked out, the name of the company and person locking the system out, and the method to contact the person or company affixing the lockout.
Isolate the System	Shut off all energy sources including electrical, air, pneumatic, gravity, chemical, light, thermal, valves, and breakers. When possible, disconnect any possible contact between the machine and the energy source. Many systems or machines may have a main power source and additional control systems on separate circuits. Be sure you lock out all power sources. Coordinate with other contractors and the owner’s skilled tradesmen and engineers.



Lock It Out	Put a lock directly on the power disconnect or if necessary on a chain or other external mechanical device to ensure it cannot be activated. Each person who will work on the equipment must place their own lock and tag on each energizing source (or on a lockbox containing control keys). Multiple locking adapters (clamps or hasps) are available when the number of locks needed for proper lockout exceeds the amount that the breaker or disconnect switch can accommodate. Some equipment may require four or more disconnects to de-energize the equipment. All sources must be locked out; additional locks are available from the supervisor. The individual who attached the lock must have the only key on his or her person. The key is not to be passed to another individual. (Exception is during shift change lockout transfer; see next page.)
Tag It Out	Complete the information required on the lockout tag and attach to the lock, lockbox, multilock clamp, or the device.
Try It Out	<p>The most important step in a lockout procedure is to try to turn on the machine or system that is believed to be locked out. Locking out the breaker or disconnect switch will not be considered adequate assurance that equipment is isolated. After the locks and tags have been attached, each person must check for proper lockout by attempting to start the equipment.</p> <p>All persons involved in locking out the equipment will be informed when the attempt is made to start the equipment. Be certain all persons are clearly out of the danger areas before testing the lockout. If there is no movement or other indication of residual energy, then you know you have zero energy state. Remember gravity energy and neutralize it by blocking moving parts, bleeding lines, etc.</p>

Examples of energy sources and systems that are required to be locked out.

*Customer or Owner’s Equipment Interface (New)*

Live electrical systems shall be locked out whenever any service work is performed. This requirement will remain in effect any time any contractor is performing any type of work on the system. Any time repairs or modifications are made to electrical systems, either temporary or permanent, they shall be locked out. Locks shall be applied to the main disconnect switch whenever possible. All locks must be accompanied with a tag.

*Tests and Repairs*

Electrical systems and similar systems that provide power to equipment, such as pumps and electrical motors, shall be locked out any time work is performed on the system.

Pipelines, valves, and other energy sources that could be inadvertently activated, causing a hazardous condition, shall be locked out, blanked off, and otherwise secured to prevent accidental activation. Blinds in piping systems shall be securely inserted so they remain in place during the lockout period and be constructed of a material that is compatible with the material in the system.

Lines, valves, and similar systems that are being tested pneumatically or with other gases (such as nitrogen) shall be tagged as a test condition for those parts that must be activated for the test. Other parts that are in off position will require a lock with the tag.

Areas affected by the pressure test shall also be signed, roped, taped, and/or otherwise designated as no entry for nonessential persons. Such a condition shall be inspected by the safety representative or project manager before the start of the test.

**Do not forget the effects of gravity on a system.** Pipes on a slope can release liquids unexpectedly. Presses can release the hammer even with the power off. Capacitors can release electrical energy



unexpectedly. Be certain these energy sources are secured.

### *Procedure for Shift-Change Lockout Transfer*

There will be occasions when a person's work shift ends before completing work on equipment they have locked out. In most circumstances, the lock may remain in place and the system locked out until the next day or work shift. However, if someone else is expected to finish the work during the interim period before the person's next scheduled work shift, then they will be responsible for a lockout transfer. The lockout transfer will be accomplished in the following manner:

- » The supervisor having jurisdiction in the area where the equipment is located must be made aware that a request for a lockout transfer is being made.
- » The supervisor will accompany the person who has the equipment locked out to the site of the lockout and place his own lockout lock and danger tag on the equipment requiring lockout.
- » After, and only after, the supervisor's lock and tag are in place, the person who requested the lockout transfer may remove their lock and tag.
- » The supervisor will maintain their lock and tag on the breaker or disconnect switch until the person who will complete the work has placed his lock and tag and completes the remainder of the requirements of the lockout procedure.
- » The subsequent shift supervisor accepts the lockout transfer by receiving the key for the lockout lock from the supervisor they are relieving. The receiving shift supervisor must verify proper lockout and sign the lockout log as soon as possible after the key transfer. This is the only circumstance that a lock, tag, or key system is shared.
- » Projects may also require that all employees remove their locks at the conclusion of each shift, regardless of the progress of work completed; only the supervisor's lock and tag would then remain on the lockout box or system.

### **Procedure for Removal of Lock**

When an individual has completed work and is prepared to remove their lock, they should check for the presence of energy by depressing the "stop" button. This action will ensure the circuit is still in the "off" mode and will not start up when the breaker or disconnect is re-energized. The lock and tags should then be removed. No individual shall remove another's lock and tag. The only exception for lock and tag removal is noted below.

### **Forcible Removal of Lock**

There may be occasions when a person who has worked on equipment under lockout has left the plant. In the event their lock must be removed, the following will be required:

- » Every effort shall be made to contact this person to obtain permission to remove the lock. Usually a minimum of three phone calls 30 minutes apart are made in an attempt to locate the whereabouts of the individual.
- » If they cannot be located, the area supervisor shall be responsible for taking whatever action is necessary to ensure that personnel will not be endangered or equipment damaged before the lock is removed. In any case, they will thoroughly inspect the equipment and ensure there are no workers in the danger area.
- » The supervisor will consult a member of the Safety Department before any safety lock is forcibly removed. Often, the owner's Safety Department or area representative is also notified.
- » The supervisor must be present when the lock is cut off.



### **Rotating Equipment Not Restricted by Lockout**

There will be occasions when locking-out equipment will not be sufficient to eliminate the hazard from moving parts. Especially hazardous are blowers that have blades with large surface areas. Any air movement, such as a back draft, may cause the blades to rotate, causing a severe pinch-point hazard. Thus, an additional lockout point is needed to control the blades from movement. A chain with a lock shall be attached to the blade (if possible) to control movement. If not, the hazard can be reduced by blocking the rotor or the drive shaft with a 2x4, or with some other construction-grade timber.

### **Maintenance Check of Equipment**

There will be special cases where maintenance personnel must energize unguarded equipment to check shaft or gear alignment, timing, etc. In these cases, the maintenance persons involved shall contact the area foreman to stand by while they check the energized equipment. They shall also put a danger tag on the breaker and any other remote-starting station before energizing the equipment. The foreman and maintenance persons will be responsible for keeping other people clear of the equipment until it has been properly guarded or locked out. Necessary precautions may include roping off the area or using barricades.

### **Training**

Alberici will provide training to ensure that the purpose and function of the energy control program is understood by affected employees and that employees have acquired the knowledge and skills required for the safe application, use, and removal of energy controls.

Training shall include the purpose and correct use of lockout, recognition of hazardous energy sources, and the means and methods of controlling the hazards. Other employees in the area should be aware that the equipment is locked out and should not attempt to start the equipment or system, nor should they tamper with tags and/or locks.

Employees should be instructed to use locks whenever possible. They should also learn the limitations of tags, which do not ensure the system is secured.

Whenever lockout procedures are required during a project, the AHA should reflect the steps of the procedure and lockout should routinely be discussed by the Supervisor in SafeCard meetings or Toolbox Talks.

### **Work on Energized Electrical Equipment**

There will be special cases where a qualified electrician, electrical engineer, and instrument personnel must work on the equipment “hot” (not locked out). Only these people are authorized to do so. Contact the Safety Department before this work is started.

Any deviation from this procedure will be noted in a separate department procedure and approved by the Safety Department.



## MACHINES AND MACHINE GUARDING

OSHA has specific requirements for various types of machines. Those requirements are in OSHA Construction Standards 1926.300 through 1936.307 (Tools – Hand & Powered) and General Industry Standards (Machinery & Machine Guarding) Subpart O 1910.211 through 1910.219.

Many types of machines require guarding. The importance of proper machine guarding cannot be overstated. Machine guarding is generally divided into two types:

- » Point of operation
- » Power transmission

Point-of-operation guarding refers to the part of the machine where work is performed on the material. Point of operation usually involves cutting, punching, shearing, pressing, or other forms of movement. Hazards may also include chips, sharp edges, dust, and other items.

Power transmission guarding refers to the part where power is transferred from the power source (motor, hydraulic pressure, engine, etc.) to the point of operation. This transfer usually involves the use of belts, gears, shafts, or some form of mechanical device.

In all circumstances, training is required when using tools, and a supervisor must validate the training through hands-on observations before any worker uses a tool they may be unfamiliar with. The safety aspects of the tool's use should be detailed in a AHA, and supervisors must routinely review tool use in SafeCard meetings and/or Toolbox Talks.

One or more methods of machine guarding are required to protect employees in the machine area from hazards created by point of operation, power transmission, ingoing nip points, rotating parts, flying chips, and sparks.

Guards shall be affixed to the machine where possible and secured elsewhere if not possible. A guard shall not be an accident hazard in itself.

- » Revolving drums, barrels, and containers shall be guarded by an enclosure that is interlocked with the drive mechanism.
- » When the periphery of fan blades is less than 7 feet above the floor or working level, the blades shall be guarded with a guard having openings no larger than ½-inch.

### Anchoring Fixed Machinery

Machines designed for a fixed location shall be anchored to prevent walking or moving.

### Woodworking Machinery Requirements

A mechanical or electrical power control shall be provided on each machine so operators can cut off the power from each machine without leaving their position at the point of operation.

On applications where injury to the operator might result if motors were to restart after power failures, provision shall be made to prevent machines from automatically restarting upon restoration of power.

Power, operating, and emergency controls should be located within easy reach of the operators while they are at their regular work location, making it unnecessary for them to put any part of their body in danger.



## Specific Machine Requirements

Specific guarding requirements for woodworking machines are found in OSHA Standard 1910.213. Some of those requirements are noted below.

All woodworking machinery—such as table saws, swing saws, radial saws, bandsaws, jointers, tensioning machines, boring and mortising machines, shapers, planers, lathers, sanders, veneer cutters, and other miscellaneous woodworking machinery—shall be effectively guarded to protect the operator and other employees from hazards inherent to their operation.

### Table Saws

Circular table saws shall have a hood over the portion of the saw above the table, mounted so the hood will automatically adjust itself to the thickness of, and remain in contact with, the material being cut.

Circular table saws shall have a spreader aligned with the blade, spaced no more than ½-inch behind the largest blade mounted in the saw. The provision of a spreader in connection with grooving, dadoing, or rabbeting is not required.

Circular table saws used for ripping shall have non-kickback fingers or dogs.

Feed rolls and blades of self-feed circular saws shall be protected by a hood or guard to prevent the operator's hand from coming into contact with the in-running rolls at any point.

### Swing or Sliding Cutoff Saws

All swing or sliding cutoff saws shall be provided with a hood that will completely enclose the upper half of the saw.

Limit stops shall be provided to prevent swing or sliding cutoff saws from extending beyond the front or back edges of the table.

Each swing or sliding cutoff saw shall be provided with an effective device to return the saw automatically to the back of the table when released at any point of its travel.

Inverted sawing or swing cutoff saws shall be provided with a hood that will cover the part of the saw that protrudes above the top of the table or material being cut.

### Radial Saws

The upper hood shall completely enclose the upper portion of the blade down to a point that will include the end of the saw arbor. The sides of the lower exposed portion of the blade shall be guarded to the full diameter of the blade by a device that will automatically adjust itself to the thickness of the stock and remain in contact with the stock being cut.

Radial saws used for ripping shall have non-kickback fingers or dogs.

An adjustable stop shall be provided to prevent the forward travel of the blade beyond the position necessary to complete the cut in repetitive operations.

Installation shall be in such a manner that the front end of the unit will be slightly higher than the rear, causing the cutting head to return gently to the starting position when released by the operator.



## **Bandsaws and Band Resaws**

All portions of the saw blade shall be enclosed or guarded, except for the working portion of the blade between the bottom of the guide rolls and the table.

Bandsaw wheels shall be fully encased. The outside periphery of the enclosure shall be solid. The front and back shall be either solid or wire mesh or perforated metal.

## **Miscellaneous Woodworking Machines**

The mention of specific machines in previous paragraphs is not intended to exclude other woodworking machines from the requirement that suitable guards and exhaust hoods be provided to reduce to a minimum the hazard due to the point of operation of such machines.

## **Abrasive Wheel Machinery**

This section regulates only abrasive wheel machinery and does not apply to handheld grinders. (See “Hand- and Portable-Powered Tools” section for handheld equipment.) It does not cover wire wheels, buffing wheels or similar machines. An abrasive wheel is made up of individual particles that are bonded together to form a wheel. The hazard here, of course, is that if not properly mounted and used, the wheel can literally explode. Sections of the wheel may fly out at high speeds and can strike the operator or others in the working area, causing serious injury or death.

## **General Requirements**

### *Machine Guarding*

Abrasive wheels shall be used only on machines provided with safety guards, with the following exceptions:

- » Wheels used for internal work while within the work being ground
- » Mounted wheels, used in portable operations, 2 inches and smaller in diameter

### *Guard Design*

Abrasive wheel safety guards shall cover the spindle end, nut, and flange projections, except:

- » Safety guards on all operations where the work provides a suitable measure of protection to the operator may be so constructed that the spindle end, nut, and outer flange are exposed
- » Where the nature of the work is such as to entirely cover the side of the wheel, the side covers of the guard may be omitted
- » The spindle end, nut, and outer flange may be exposed on machines designed as portable saws

### *Work Rests*

On offhand grinding machines, adjustable work rests of rigid construction shall be used to support the work. Work rests shall be kept adjusted closely to the wheel with a maximum opening of 1/8 inch to prevent the work from being jammed between the wheel and the rest, which may cause breakage.

### *Angular Exposure*

Abrasive wheel safety guards for bench and floor stands and cylindrical grinders shall not expose the grinding wheel periphery for more than 65 degrees above the horizontal plane of the wheel spindle.

### *Exposure Adjustment*

The protecting member of the abrasive wheel safety guard shall be adjustable for variations in wheel size so that the distance between the wheel periphery and the adjustable tongue, or the end of the



peripheral member at the top, shall not exceed 1/4 inch.

### *Mounting*

Immediately before mounting, all wheels shall be closely inspected and sounded by the user (ring test) to make sure they have not been damaged. Workers must be trained to know how to perform the ring test. The spindle speed of the machine shall be checked before mounting the wheel to ensure it does not exceed the maximum operating speed marked on the wheel.

### *Mechanical Power Presses*

Mechanical power presses include machines known as “ironworkers” or “piranhas,” which are used for shearing and punching steel. This is a specialized and complex topic. There are, however, some basic rules:

- » Alberici will provide and ensure the use of point-of-operation guards or properly applied and adjusted point-of-operation devices. These devices are designed to prevent entry of hands or fingers to the point of operation by reaching through, over, under, and around the guard on every operation performed on a mechanical power press.
- » A substantial guard shall be placed over the treadle on foot-operated presses.
- » Pedal counterweights, if provided on foot-operated presses, shall have the path of travel of the weight enclosed.
- » Machines using full-revolution clutches shall incorporate a single stroke mechanism, except where automatically led in continuous operation and where points of operation are fully safeguarded by a fixed barrier guard.
- » Personnel using these tools must be aware of the hazards of the machine and proper preventive maintenance of the equipment prior to placing into operation on a project site. The manufacturer often has training material including videos specific to this type of equipment. Alberici shall establish a program of regular inspections of their power presses to ensure safe operating conditions and shall maintain a record of inspections and maintenance work. The project supervisor should assign this task to one individual.

*All point-of-operation injuries are required to be reported to OSHA. Contact the Safety Department, who will report to OSHA or the state agency within 30 days.*



## MOBILE ELEVATED WORK PLATFORMS (MEWP, AERIAL LIFTS)

Alberici requires that all personnel use a personal fall-arrest system anytime work is performed from an aerial lift—including scissors lifts, aerial baskets, or any other type of aerial work platform. There is no exception to this requirement.

### References

Section 1926.556, Subpart L – Scaffolds  
ANSI A92.22 and ANSI A92.24

It is our responsibility to develop specific requirements and assign only persons who have been well-trained and are competent to operate this type of equipment. At project startup, or when new employees arrive on site, anyone assigned to operate aerial lifts must be trained on the particular type of machine in use and a performance evaluation completed before the person actually begins operating the equipment. Operator certification is valid for three years from the date of training.

### Scope

These rules apply to equipment that has a primary function of elevating personnel, together with their tools and necessary material, on a platform that is mechanically positioned.

### Manufacturer's Construction

ANSI A92.20, Design; ANSI 92.22, Safe Use and ANSI 92.24, Training Requirements are referenced.

1. Aerial work platforms shall be designed, constructed, and tested to comply with the requirements referenced by OSHA of:
  - a. ANSI standard A92.3-2006 (or later edition), manually propelled elevating and rotating aerial devices
  - b. ANSI standard A92.5-1992 (or later edition), boom-supported elevating work platforms
  - c. ANSI standard A92.6-1999 (or later edition), self-propelled elevating and rotating aerial devices
2. Aerial work platforms shall not be field-modified for uses other than those intended by the manufacturer, unless the modification has been certified in writing. Certification can come from the manufacturer or from an equivalent entity, such as a nationally recognized testing laboratory, to comply with the applicable ANSI standard and this rule. An example of field modification includes constructing or connecting a device on the basket to hold tools or materials.
3. Directional controls will be:
  - a. The type that automatically returns to the off or neutral position when released
  - b. Protected against inadvertent operation
  - c. Clearly marked as to their intended function
  - d. Provided with an overriding control, in the platform, that must be continuously activated for platform directional controls to be operational and that automatically returns to the off position when released
4. Aerial work platforms shall be equipped with emergency controls at ground level. The key to operate the emergency ground control shall remain with the aerial work platform and in plain view at ground level when anyone is using the aerial work platform in an elevated position.
5. Emergency ground-level controls shall be clearly marked as to the intended function and be capable of overriding the platform controls.
6. The following information shall be clearly marked in a permanent manner on each aerial work platform:
  - a. Special warnings, cautions, or restrictions necessary for operation
  - b. If rated workload is not clearly marked, the aerial work platform shall be red tagged and removed from service until corrected



7. Rotating shafts and other moving parts that are exposed to contact must be guarded.
8. Attachment points shall be provided for fall protection devices for personnel who occupy the platform on aerial work platforms.

### Inspection, Maintenance, and Testing

All operators of MEWP shall comply with all the following requirements:

1. Each aerial work platform shall be inspected, maintained, repaired, and kept in proper working condition in accordance with the manufacturer's or owner's operating or maintenance and repair manuals.
2. Any aerial work platform found not to be in safe operating condition shall be repaired by an authorized person in accordance with the manufacturer's or owner's operating or maintenance and repair manuals.
3. If the aerial work platform is rated and used as an insulated aerial device, the electrical insulating components shall be tested for compliance with the rating of the aerial work platform, in accordance with ANSI standard A92.2-1990. Such testing shall comply with the following provisions:
  - a. The test shall be performed at least once a year.
  - b. Written, dated, and signed test reports shall be obtained by the project site using the device.
4. All danger, caution, and control markings and operational plates shall be legible and not obscured.

### MEWP Operational Procedures

Sites that anticipate use of MEWP must perform a site risk assessment. Operators qualified to use the mobile elevated work platform must perform the following actions.

#### *Pre-start*

1. Before use on each work shift, the operator shall visually inspect a MEWP for defects that would affect its safe operation and use. Visual inspection of the following:
  - a. Cracked welds
  - b. Bent or broken structural members
  - c. Hydraulic or fuel leaks
  - d. Damaged controls and cables
  - e. Loose wires
  - f. Tire condition
  - g. Fuel and hydraulic fluid levels
  - h. Slippery conditions on the platform

Test the operation of all platform and ground controls to ensure they perform the intended functions. The key must be present in the ground controls when the machine is in use.

2. Before an MEWP is used and during use on the project site, the operator shall check for the following:
  - a. Ditches
  - b. Drop-offs
  - c. Holes
  - d. Bump and floor obstructions
  - e. Debris
  - f. Overhead obstructions
  - g. Power lines
  - h. Conveyor lines



- i. Other traffic in the area
- 3. All unsafe items found from MEWP or work area inspection shall be corrected before further use of the MEWP.

[MEWP/aerial lift inspection form.](#)

*Operating Procedures*

1. The MEWP shall be used only in accordance with the manufacturer’s or owner’s operating instructions.
2. When operating MEWP or other equipment under, over, by, or near energized electric power lines, the following clearances shall be maintained:

Voltage	Minimum Clearance
0-50 KV	20 feet
Over 50 KV	20 feet + 0.4 inches per KV

3. Two licensed electrical journeymen will be required for work within the minimum clearance on equipment over 0.5 kv.
4. Proximity warning devices may be used, but not instead of meeting the requirements above.
5. Any overhead electric line, piping, or similar element shall be considered energized until the owner of the line or their authorized representative states that it is de-energized and applies a lockout.
6. The manufacturer’s rated load capacity shall not be exceeded. The employer shall ensure that the load and its distribution on the platform are in accordance with manufacturer’s specifications. The MEWP rated load capacity shall not be exceeded when loads are transferred to the platform at elevated heights.
7. Only personnel, their tools, and necessary materials shall be on the platform.
8. The guardrail system of the platform shall not be used to support any of the following:
  - a. Materials
  - b. Other work platforms
  - c. Employees
9. Personnel shall maintain firm footing on the platform unless site management has issued a task-specific variance.
10. The use of railings, planks, ladders, or any other devices for achieving additional height on the platform is prohibited unless manufactured work platforms to elevate personnel are available and used when workers must work above the platform.
11. Fuel gas cylinders shall not be carried on the platforms.
12. Alberici shall provide a safety harness with a lanyard that is complies with construction safety standards, fixed to attachment points provided and approved by the manufacturer. Harnesses and lanyards secured to attachment points must be used by any occupant of a MEWP.
13. Tying off to an adjacent pole, structure, or equipment while working from a MEWP is prohibited.
14. Employees shall not be allowed to exit an elevated MEWP except where elevated work areas are inaccessible or hazardous to reach. Employees may exit the platform with the knowledge and consent of the employer and will be included in the site- or task-specific AHA. When exiting to unguarded work areas, fall protection shall be provided and 100% fall protection procedure shall be used with the double lanyard method. Remain tied off to the basket, reach out and tie off to the structure, release from the tie-off point of the basket, and exit through the entry gate.
15. Only work platforms that are equipped with the manufacturer’s installed platform controls for horizontal movement shall be moved while in the elevated position.
16. Before and during driving while elevated, an operator of a platform shall do the following:



- a. Look in the direction of, and keep a clear view of, the path of travel and make sure that the path is clear, firm, and level.
- b. Maintain a safe distance from all the following:
  - c. Obstacles
  - d. Debris
  - e. Drop-offs
  - f. Holes
  - g. Depressions
  - h. Ramps
  - i. Overhead obstructions
  - j. Overhead electrical lines
  - k. Other hazards to safe elevated travel
17. Outriggers or stabilizers, when provided, are to be used in accordance with the manufacturer's instructions. Outriggers and stabilizers shall be positioned on pads or a solid surface.
18. MEWPs shall be elevated only when on a firm and level surface or within the slope limits allowed by the manufacturer's instructions.
19. Platform gates shall be closed while the platform is in an elevated position.
20. Stunt driving and horseplay are prohibited.
21. Altering, modifying, or disabling safety devices or interlocks is absolutely prohibited.
22. Care shall be taken by the employer to prevent ropes, cords, and hoses from becoming entangled in the MEWP.
23. A platform operator shall ensure that the area surrounding the aerial work is clear of personnel and equipment before lowering the platform. The ground person will assist the operator in determining hazards on the ground and help the operator avoid any hazards.
24. Before and during travel, an operator shall do all the following:
  - a. Inspect to see that booms, platforms, aerial ladders, or towers are properly cradled and/or secured
  - b. Ensure that outriggers are in a stored position
  - c. Limit travel speed according to the following factors:
    - i. Condition of the surface
    - ii. Congestion
    - iii. Slope
    - iv. Location of personnel
    - v. Other hazards
25. The MEWP shall not be positioned against another object to steady the platform.
26. The MEWP shall not be operated from a position on a truck, trailer, railway car, floating vessel, scaffold, or similar vehicle or equipment.
27. The boom and platform of the MEWP shall not be used to move or jack the wheels off the ground unless manufacture designed the machine for that purpose.
28. If the platform or elevating assembly becomes caught or snagged or is otherwise prevented from moving normally by adjacent structures or other obstacles, such that control reversal does not free the platform, all personnel shall be removed from the platform before attempts are made to free the platform.
29. In most situations, MEWP should be properly barricaded, using snow fence, cones, barrier tape, or other devices to prevent work from occurring near or below the MEWP. Ground persons, spotters, and escorts must wear a high-visibility reflective vest and remain in sight of the operator. If the operator is unable to see the escort, they are not to move the MEWP until visual contact can be reestablished.
30. Some owners require strobe lights and/or back-up alarms on all MEWP. Be certain to review owner criteria prior to job start-up.
31. If hot work is to take place in a MEWP, a fire extinguisher must be in the basket of the MEWP and



inspected daily as part of the operator's start-up routine.

32. A rescue/retrieval-from-heights plan must be part of the site-specific safety plan when workers are using MEWP.

### **Variances to Scissor Lift and Boom Lift Safety**

Exceptions may be made that allow employees to work above the guardrail on scissor lifts and articulating boom lifts (mobile elevating work platform, or MEWP). Before this is permitted, we analyze ways to perform work at elevated positions (over 6 feet). Our goal is to find the safest way to accomplish the work given the overhead and physical access constraints. We analyze the risk to employees using the MEWPs in this manner vs. the risk that other methods such as erecting and dismantling scaffolds and use of extension ladders would expose our employees to.

In our review, we discuss our goals for achieving the safest way to do our work with OSHA, equipment manufacturers, and other contractors. Our consensus is that for some tasks and physical limitations we will allow our employees to work above and outside the guardrail protection while implementing additional safety requirements. The mechanical lifts have less risk to employees than building, working on, and dismantling scaffolds; placing and working on and from extension ladders; or climbing on and around trusses, beams, conduit, and HVAC duct.

Working in and from mechanical lifts is less dangerous than working from scaffolds and ladders for many tasks, but it is still dangerous. **Working above the guardrail of a lift is last resort to perform the work.** Other ways and means shall be reviewed before working above or outside the lift.

We **do allow** working above the equipment guardrail when the employee is standing on a stable platform of adequate width, appropriate strength, and securely attached to the lift, and the employee is tied off with the required fall arrest equipment attached to an approved tie-off point inside the lift. Contact the equipment manufacturer to see if they have an approved work safe platform that allows the worker, when appropriately tied off, to gain an additional 19 inches of work. If the employee works outside the perimeter of the lift, **to maintain 100% tie-off** they are to use their second lanyard to tie off to a secure point and then unsnap their first lanyard from the lift. **To reenter the lift, reverse the process.**

Following are some of the safe work practices that are mandatory for employees working with a MEWP. All employees must be diligent and consistent in complying with these requirements.

- » The employee must be certified competent in the use of the equipment they are operating and be able to supply proof of the training.
- » MEWP manufacturers, OSHA, and Alberici do not allow employees to stand on the midrail or guardrail to work above or outside the guardrail.
- » The perimeter of the lift must be protected from impact of falling debris, materials, tools, or equipment (including other scissor or boom lifts).
- » The lift's platform shall be organized to remove tripping hazards.
- » The specific activity must be defined on a AHA that states why other options are a greater risk.
- » The lift must have engineered tie-off points developed by the manufacturer.
- » Employees must wear the appropriate fall arrest system when working in or moving a lift.
- » The employee shall be tied off 100% of the time when working in the lift or outside the lift.
- » Employees shall attach a stable temporary platform to the lift and stand on the platform in the lift 100% of the time when working above the guardrails.



- » No tools, equipment, or materials are to be stored on the temporary platform. Total weight of tools, equipment, and personnel is not to exceed rated capacity.
- » All temporary platforms are to be immediately removed from the lift each day and upon task completion.
- » The lift can only be operated when all personnel are standing on the floor of the platform inside of the lift.
- » Employees shall attach the second lanyard to a secure tie-off point 100% of the time when exiting the lift or working outside the perimeter of the lift. That is the only time the employee is not tied off to the lift.
- » The employee is to be tied off when working or moving in a scissors lift or boom lift at all heights.
- » When the employee accesses a lift to work or move it, the employee is to be tied off 100% of the time off to an approved secure point on the lift.
- » The only time an employee is not required to be tied off is when the lift platform is at ground level (no higher than 6 feet above level below), the lift is not turned on or running, and the employee is loading or unloading materials or inspecting the lift.

### **Rescue/Retrieval Plan – Work from Heights – MEWP**

OSHA 1926.502(d)(20) states: “The employer shall provide for prompt rescue of employees in the event of a fall or shall assure that employees are able to rescue themselves.”

#### *Self-Rescue*

Self-rescue is achieved when the worker can successfully return to a stable platform if they fall or slip from a beam, off a leading edge, or out of an elevated work platform when they are using a personal fall arrest system (PFAS).

#### *Assisted Rescue*

Assisted rescue plans must be developed prior to any work from heights. Plans must include training of personnel, identification of equipment, type of rescue intended, personnel involved in rescue, and a detailed description of the plan.

#### *Technical Rescue*

Technical rescue is used when there is an outside, trained response team available to perform rescue. This must be an agency that has qualified their workers to perform high-angle/rope rescue in many configurations. They must be involved in planning the rescue and any training drills that occur.

Developing a work-from-heights assisted or technical rescue plan:

- » Understand how, where, and what type of work is being completed
- » Know where the rescue equipment is located and whether it is in proper working order
- » Document that equipment will be available immediately should a fall occur
- » Have properly inspected fall protection gear that is readily accessible to assist the suspended worker
- » Ensure that the project has an emergency contact list and everyone can be contacted quickly
- » Designate someone to call 911
- » Know who is assigned to rescue and identify on daily whether they are in close proximity to the elevated work.



- » Document how communication will occur between a suspended worker and the rescue team
- » Identify whether there is anything that could obstruct a rescue
- » Form a step-by-step procedure for a self-rescue and assisted rescue plan
- » Document how rescue personnel will be kept safe during a rescue

### *Rehearse*

- » Practice your rescue plan from a safe level. Drill it frequently.
- » Your team should be well-trained in every part of the rescue process. To help with this, alternate roles so everyone knows every step of the process.
- » Each task is unique and will need its own plan. Your plan can be as simple as grabbing a ladder or MEWP, or your work might need a 12-step process.
- » Assign someone to call 911 as soon as the fall occurs. That way, once your employee is safely on the ground, emergency services can take action.
- » Do not anticipate that outside services will have the capabilities to rescue workers at heights.



## POWERED INDUSTRIAL TRUCKS

### Training Requirements

Operators shall be trained before they are permitted to operate any type of powered industrial truck, including fork trucks. The training must consist of both classroom and practical training. Operators who have completed the training must then be evaluated while they operate the equipment in the workplace. The training requirement applies to employees who are assigned full-time as operators and those employees who also have other duties.

Certified equipment operators and Alberici-trained operating engineers are licensed for three years from the date of that training if it can be verified in writing, and it meets the applicable requirements of OSHA. In this case, Alberici will only evaluate the operator's skill level; if acceptable, there is no need to retrain the operator. Training and evaluation must be documented. The training provided to operators will include:

- » A review of the operator's manual
- » Operating instructions, warnings, and precautions for the types of truck the operator will be authorized to operate
- » Differences between the truck and an automobile
- » Truck controls and instrumentation: where instruments are located, what they do, how they work, etc.
- » Engine and motor operation
- » Steering and maneuvering
- » Visibility (including restrictions)
- » Fork and attachment adaptation, operation, and use limitations
- » Vehicle capacity and limitations
- » Vehicle stability
- » Vehicle inspection and maintenance
- » Refueling and/or recharging of batteries
- » Use of vehicle on various floor surfaces
- » Recognizing areas where carbon monoxide may accumulate
- » Composition of the load and load stability
- » Load manipulation and stacking/unstacking
- » Pedestrian traffic in the area
- » Hazardous locations where the truck may be operated
- » Other conditions that may affect the operation of the truck
- » Personal protective equipment

### Refresher Training

Refresher training and evaluation will be provided to the operator when:

- » The operator is assigned to operate a different type of truck or conditions in the workplace have changed in a manner that affects the safe operation of the truck
- » The operator has been observed to operate the truck unsafely



- » The operator has been involved in an accident or a near-miss incident
- » The operator has received an evaluation that reveals they are not operating the truck safely

### **Re-Evaluation of Operators**

Operators will be re-evaluated at least once every three years.

### **Certification of Operators**

Operators who have received training and passed the evaluation will be certified. The written certification will include the name of the operator, the identity of the person performing the training and evaluation, the date of the training, date of the evaluation, and the type of truck the person is certified to operate.

### **Records**

Training and certification records will be maintained by the Training Department and will be available to project management or the operator on a need-to-know basis.

### **General Requirements**

All powered industrial trucks used by Alberici and our subcontractors will be equipped with an operating backup alarm. The alarm must be audible above other noise in the area. Personnel who are required to work in the area around powered industrial trucks must wear high-visibility, reflectorized vests, as are groundmen or spotters working with the lift truck operator.

All units will be equipped with overhead protection unless otherwise specifically approved by the safety director or their representative. If seat belts are provided, they must be worn.

Powered industrial trucks will not be used to elevate personnel except as approved by the safety director and only after all other options have been reviewed and rejected. When the forklift is parked, the forks are grounded, brakes are set, engine is off, and keys should be removed.

All operators shall wear, at a minimum, seat belts.

Operators shall wear personal protective equipment such as safety glasses with side shields, work boots, and proper clothing. Gloves and safety helmets will be worn in construction environments, where they do not impede operation of the unit.

### **Inspections**

All forklifts shall be inspected daily and the inspection documented using the Alberici Operators Inspection Booklet. Any deficiencies affecting safe operation of the forklift shall be noted and the forklift shall not be operated until repairs have been made. Completed inspection reports shall be retained at the jobsite, until forwarded to the equipment manager for archival.



## PERSONAL PROTECTIVE EQUIPMENT (PPE)

PPE is not an effective substitute for practicing safe work behaviors, engineering, or administrative controls, nor does the use of PPE by itself reduce the risk of injury due to unsafe conditions. PPE is most effective when used in conjunction with the other elements of the Built In Safety Program that stress use of safe work practices and rapid identification and correction of unsafe conditions. Where possible, eliminating hazards, substitution, engineering, or administrative controls are to be implemented prior to using PPE to mitigate the hazard. PPE should always be used when engineering and administrative controls are not sufficient to reduce the hazard to an acceptable level.

PPE required by OSHA or identified by the site-specific safety plan and/or the applicable AHA is available to all project personnel and provided by Alberici at no cost to the employee.

Employer-paid PPE is not intended to include such items as shirts, pants, eyeglasses, and safety-toed boots that are allowed to be worn off the project site.

Standard PPE provided to all field personnel at no cost includes:

- » Type 2 helmet with integrated chin straps meeting requirements of the most current ANSI 89.1 standard for impact protection
- » Safety glasses with side shields meeting the most current ANSI Z87.1+ standard
- » High-visibility safety vest and appropriate gloves for the task
- » Hearing protection where applicable
- » Respiratory protection where applicable
- » Fall protection where applicable
- » Minimum cut level 4 gloves

All site personnel are required to meet this minimum level of PPE prior to performing any on-site field activities.

Employees must inspect their personal protective equipment daily and ensure it is in sound working order and complies with manufacturers' recommendations. The frequency of distribution of PPE will conform with OSHA requirements, Alberici or site policy, and/or current labor agreements.

A wide range of additional PPE is available on an as-needed basis. Use of supplemental PPE is required where identified in a site-specific AHA.

### Fall Protection

All persons performing elevated work greater than 6 feet off the ground shall comply with Alberici's 100% fall protection and tie-off requirement.

Every Alberici employee performing elevated work is required to wear a full body harness, fall-arresting lanyard or self-retracting lanyard (SRL) and other elements of a complete personal fall arrest system (PFAS).

The type of lanyard should be specified in the task-specific AHA.



## Safety Helmets

Alberici requires Type 2 safety helmets with integrated chin straps. If a worker is performing welding activities or work where this creates a hazard, the alternate method should be addressed on a SafeCard or AHA. Ball caps, knit caps, or hoods should not be worn under a hard hat. Use only headwear designed for that purpose.

## Eye Protection

Alberici provides safety glasses with side shields, goggles, and face shields to protect against particles, debris, metal chips, etc. that pose potential hazards to the eyes and face.

Wearing side shields with non-safety prescription eyewear is not allowed. Workers requiring prescription eyewear must have Z87.2+ safety glasses or use over the glasses (OTG) eyewear.

Clear safety glasses are provided for use inside buildings and in low light conditions.

Tinted safety glasses are provided for daytime use outdoors in bright sun conditions. Tinted safety glasses are not to be worn indoors or in low light conditions. Several manufacturers provide indoor/outdoor (I/O) safety glasses that reduce outdoor glare to an acceptable level while allowing sufficient light to pass through the lens to be allowable for use in lower light, indoor conditions. Confirm acceptance of I/O glasses with owner requirements. All eye and face PPE shall meet the requirements of ANSI Z87.1+.

Foam-lined safety glasses/monogoggles may be required for specific tasks such as work around boiler houses, precipitators, areas with high concentrations of fly ash, etc.

Like foam-lined safety glasses or monogoggles, face shields are to be worn when additional eye/face protection is needed when performing tasks such as burr grinding, chipping, cutting or grinding concrete, handling corrosive chemicals, etc.

## Respiratory Protection

To provide protection from potential airborne hazards, Alberici has developed, implemented, and maintains a respiratory protection program. This program is administered by the Safety Department and conforms to applicable regulatory standards (29 CFR § 1910.134).

Program elements include:

- » A written respiratory protection program with required worksite-specific procedures
- » An annual program review
- » Pre-assignment medical evaluation including pulmonary function testing
- » Training in proper selection
- » Use and care (procedures and schedules for cleaning, disinfecting, storing, inspecting, repairing, discarding, and otherwise maintaining) of respiratory protection equipment
- » Training of employees in the respiratory hazards to which they are potentially exposed
- » Frequency of cartridge change-out
- » Procedures for fit-testing of respirators
- » Appropriate recordkeeping requirements

All respirators used by Alberici shall be NIOSH-approved.



Powered air-purifying respirators (PAPRs), air-supplied respirators, airline respirators, and self-contained breathing apparatus (SCBA) are not available for routine use. The site-specific safety plan and applicable AHA should be referenced if these types of respirators are necessary to safely perform work.

Filtering face pieces (i.e., dust masks) are available for nuisance particulates. When worn for nuisance or comfort, the employee must understand and acknowledge criteria in Appendix D of the OSHA Respiratory Standard. Various models are available for use.

For silica exposure, any N95 or N100 filter face masks will meet most protective measures as outlined in Table 1 (current as of September 2017).

When respirators of any type are used for silica exposure, projects are required to track use. After 30 days of annual use, employees must be placed into a medical monitoring program to include (initial) health history, medical examination, chest X-ray, pulmonary function test (PFT), and test for tuberculosis.

Silica medical evaluations are repeated every three years.

### **Hearing Protection**

Alberici currently complies with OSHA's Occupational Noise Standard for construction – 29CFR1926.52. This standard sets maximum noise exposure levels and requires employers to implement a hearing conservation program if employee noise exposures exceed a time-weighted average (TWA) of 85 dBA over an eight-hour workday.

Hearing protection requirements are contained in Alberici's hearing conservation program.

### **Protective Footwear**

Employees are required to wear work boots that meet current impact and compression standards per OSHA 1926.96/ASTM F2413. This means a work boot with steel or composite toes and metatarsal protection provided where applicable.

### **Protective Clothing**

A variety of protective clothing is available where required for site-specific project work. The clothing should be identified in the task-specific AHA developed prior to the performance of the work.

Disposable Tyvek coveralls can be used in tasks where particulates are a potential hazard. Poly-coated Tyvek can be used for splash protection or potential exposure to liquids, gases, or aerosols that pose contact or absorption hazards.

Various styles of rubber boots are available for use in tasks such as concrete finishing and where the potential for chemicals to contact and permeate leather boots dictates.

### **High-Visibility Vests**

Employees are required to wear high-visibility apparel, including vests, shirts, and jackets, when performing tasks that expose them to moving equipment and vehicles. This includes exposure to construction equipment (e.g., forklifts, heavy machinery), the motoring public, and vehicles involved in construction activities. High-visibility apparel must also be worn in warehouse, storage yard, fabrication shop, and other non-construction environments where exposure to moving vehicles and equipment is identified in a AHA or similar risk assessment, or as required by the work location's site rules.



Alberici will provide high-visibility apparel when required by local and state regulations, client requirements, traffic control plans, or when deemed necessary through risk assessments (AHA), site safety plans, or similar safety evaluations.

All high-visibility apparel worn for worker protection will meet at least the ANSI/ISEA 107, Class II standard.

For work conducted during nighttime or in low-light conditions, the minimum required apparel may be upgraded to ANSI/ISEA 107, Class III.

### **Hand Protection/Safety and Glove Program**

Alberici requires gloves to be worn while in work areas on our projects. Most workers and project team members need gloves that are cut-resistant level 4 or greater. This requirement is inclusive of trade partners, visitors, vendors, and suppliers. Exceptions are allowed only where site management and safety deem that the use of a glove creates a hazard or when specialty gloves are required.

Even in situations where material handling is not anticipated, project personnel may be in situations where housekeeping or clean-up of materials is required; therefore, no one is exempt from wearing gloves when in the field.

Gloves are not required when operators are operating equipment or in office settings; walking between trailers or offices; during breaks, while using toilet facilities, or during lunch periods; or while reviewing prints at the supervisor's field office location. Cut-resistant level 4 or greater gloves must be carried and worn upon completion of these activities. Under certain circumstances, cut-resistant gloves would not be used or could be contraindicated, for instance, when performing first aid or CPR; for subcontractors who perform live electrical work; when craft are working around rotating parts; or when handling chemicals where rubber or neoprene gloves are more applicable. Cut-resistant level 4 gloves may be worn beneath rubber or neoprene gloves.

These exceptions are not all-inclusive. Projects may choose to establish glove-free zones. Any variance should be addressed in the AHA and reviewed with the Alberici project team. Specific glove selection is up to each project site as long as they meet the cut-resistant level 4 rating. Alberici will provide gloves only for Alberici team members. Trade partners and others are required to provide their workers with the proper gloves and appropriate training to meet this requirement.

Hands can be endangered in many ways, and gloves alone will not prevent all injuries. However, using the right glove for the task will reduce the severity of the incident. Workplace exposure to sharp metals, heat, cold, chemicals, vibration, abrasions, and other hazards cause injuries across the construction industry. According to some research, 70% of hand injuries occur when workers are not wearing gloves. Most of the remaining injuries were related to the incorrect use or selection of gloves.

This program is intended to minimize injuries to our hands. Many of the glove types identified are specific to cuts, lacerations, punctures, and impact. Glove choice is also dependent on the work tasks being performed. Touch-sensitive fingertips may be preferred so that managers and field leaders may respond to phone calls, use iPads, or take photos, depending on the circumstances of their job.

#### *Hand Protection*

Gloves are not the exclusive “fix” to hand protection. Review of tasks and consultation with the safety team should be undertaken before decisions are made. Hierarchy of controls should be considered in all situations. The hierarchy includes eliminating the hazard, making substitutions, engineering



out hazards, administrative controls, and finally personal protective equipment.

### *General Glove Use*

OSHA specifies that employers provide hand protection from hazards that include:

- » Skin absorption of harmful substances
- » Severe cuts or lacerations
- » Severe abrasions
- » Punctures
- » Chemical burns
- » Thermal burns
- » Harmful temperature extremes

Factors that influence the selection of protective gloves include the following:

- » Type of chemicals handled, if applicable
- » Nature of contact to hazard
- » Duration of contact to hazard
- » Area requiring protection (hand, forearm, arm)
- » Grip requirements
- » Thermal protection needed
- » Abrasion and cut resistance
- » Size, style, functionality, and availability of gloves

Supervisors may determine for specific, valid reasons that cut-resistant gloves or other types of gloves may not be worn (for legitimate dexterity issues, or because of a greater hazard posed by wearing the gloves). Gloves should never be worn for tasks that have the potential to catch the glove and pull it and hands into rotating or revolving equipment. Gloves should be selected to provide maximum dexterity while also providing for sufficient cut resistance and impact resistance while performing work. Any type of hand protection must be evaluated based on the nature of the risk and performance of hand protection in relation to the task.

Project-specific AHA must assess the hazards associated with various tasks and recommend specific PPE, including gloves. Variances must be documented in the appropriate pre-task plan and daily task/hazard review.

### *Cut-Resistant Gloves*

Cut-resistant gloves are rated on a 1 – 9 basis, with the higher numbers providing increased cut resistance. Cut-level 4 and 5 gloves and upper extremity wear are defined by ANSI/ISEA as being used for medium cut hazards, including use of box blades, drywalling, glass, rough-sawn lumber, and sharp metal handling.

Medium- and high-level cut-resistant gloves and sleeves provide greatly increased cut and puncture resistance against abrasions and direct contact with sharp metals, such as sheet metal or blades. They provide greater dexterity than thick leather gloves. They are durable, have good flame resistance, and styles with a rubberized coating on the palm and fingers provide improved gripping capability. However, even these gloves and sleeves are not 100% cut- or puncture-proof. Wearers of cut-resistant gloves and sleeves should continue to be aware of the hazard and the limitations of the



gloves and continue to respect the potential for cuts and punctures.

The higher the protection level, the thicker the glove may be, and the level of dexterity may be affected.

Projects are encouraged to evaluate the most current ANSI/ISEA 105 for specifics related to glove selection. Distributors may also have gloves on their shelves that are EN-rated. The European EN 388 standard evaluates abrasion, circular cut, tear, and puncture resistance and show numerical ratings in that order. The newest EN 388 rating also evaluates performance when exposed to straight blades and are shown with a ranking from A (low) to F (high). If they also provide impact protection, they will be designated with the letter “P.” It is important to understand the classifications and protection levels based on ANSI/ISEA 105 or EN 388. Consult your safety team and the warehouse for the selection available.

Gloves shown above (HyFlex) are examples only and may not be indicative of product availability.

**Ratings Chart**

**Markings & Indications**

ANSI LEVEL	A1	A2	A3	A4	A5	A6	A7	A8	A9
CUT	CUT	CUT	CUT	CUT	CUT	CUT	CUT	CUT	CUT
Weight (grams) needed to cut through material	≥ 200	≥ 500	≥ 1000	≥ 1,500	≥ 2,200	≥ 3000	≥ 4000	≥ 5000	≥ 6000
TYPICAL TASKS	General Purpose, Warehousing, Small Parts Assembly	General Purpose, Plastics Injection and Moulding, Pulp and Paper	Raw Material Handling, General Manufacturing, Construction	HVAC, Aerospace, Food Prep	Glass or Metal Sheet Handling, Automobile Assembly, HVAC	Metal Fabrication, Glass Manufacturing, Changing Blades	Meat Prep/ Processing, Glass Manufacturing, Metal Stamping	Metal Stamping, Recycling, Heavy Assembly	Sharp metal Stamping, Recycle Sorting, Metal Fabrication

**ANSI/ISEA 105-2016 Abrasion Rating Chart**

ABRASION LEVEL RATING	0	1	2	3	4	5	6
GRAM LOAD	500	500	500	500	1000	1000	1000
ABRASION CYCLES TO FAIL	<100	≥100	≥500	≥1,000	≥3,000	≥10,000	≥20,000

*Puncture-Resistant Gloves*

**IMPACT**

Performance Level	Mean Transmitted Force	Increasing Protection
ANSI/ISEA 138 3	≤ 4kN	↑
ANSI/ISEA 138 2	≤ 6.5kN	
ANSI/ISEA 138 1	≤ 9kN	



## PUNCTURE

	LOW <span style="float: right;">HIGH</span>				
Level	1	2	3	4	5
ANSI/ISEA (Newtons)	10-19 N	20-59 N	60-99 N	100-149 N	150+ N
EN (Newtons)	20-59 N	60-99 N	100-149 N	150+ N	-

Puncture resistance generally comes from a coating applied to palm and finger areas that still allows the user to maintain dexterity. There is no such thing as puncture-proof. Material used to increase puncture resistance is stiff and may affect dexterity.

Puncture-resistant ratings are based on a 0 – 5 index, with 5 being the highest level currently available.

### *Leather Gloves*

Leather palm work gloves are the most common for hand protection and are widely used for a variety of tasks. Leather palm work gloves provide better gripping as well as better cut and abrasion resistance than cotton jersey gloves. They are available with standard and long gauntlets and are specifically intended for burning, cutting, and welding metal. (Long gauntlet leather gloves are commonly used when performing overhead welding/burning for extended periods.)

### *Coated Gloves*

Chemical or liquid-proof gloves are coated gloves. They can be obtained with or without linings that add to the comfort and fit of the glove. The key is to ensure that the coating is resistant to the type of chemicals or liquids that are present. Gloves used for protection against solvents, acids, and other chemicals must be of the type to protect against the chemical exposure. Various types include:

- » Latex (waterproof/water-resistant): Latex is highly sensitizing. Many people have severe latex allergies, so these gloves should be used with caution.
- » Nitrile for grease, oil, and petroleum-based products: May be water-resistant or waterproof if fully coated. Good for dexterity, sensitivity, and grip.
- » Polyurethane for abrasion and extended wear: Limited chemical resistance. Polymers can be harder to puncture than other coated gloves.
- » Neoprene for excellent chemical-resistant properties: Used primarily for a broad range of hazardous chemicals including acids, alcohols, oils, and inks. They provide good grip but are generally thicker and heavier than other coated gloves, which can limit their dexterity.
- » Rubber for wet processes and electrical work: Work may include chemical handling or wet and watery conditions.
- » Consult the Safety Data Sheet (SDS) for the best selection.

### *Impact-Resistant Gloves*

The ANSI/ISEA 138 standard governs the impact resistance of gloves. They must be tested by an accredited third-party laboratory by dropping a designated weight onto the impact point of the glove and recording the transferred force. This is repeated eight times on the back-of-hand area and 10 times on the fingers. Gloves receive a rating based on all the test results and the mean of the test. Ratings range from 1 to 3. Higher ratings mean a higher amount of force that the glove can dissipate.

Projects where impact hazards are possible must evaluate various impact-resistant gloves and the balance between protection and dexterity. Use impact-resistant gloves when there is a high



potential for pinch points and hands and fingers being smashed.

### *Anti-Vibration Gloves*

Vibratory-reducing gloves greatly reduce the effects of the percussion from powder-actuated tools (PAT), grinders, nail guns, sanders, and other machinery that produces high levels of vibration and the shock felt when workers are using an impact wrench to “rattle-up” bolts. If an employee is going to fire more than 10 shots with a powder-actuated tool or use an impact wrench for more than 30 minutes, it is essential that this type of glove is worn. These gloves help prevent hand-arm vibration syndrome.

### *Electrical Hazard Gloves*

Electric shock-resistant glove use is determined by the level of electrical energy from branch circuits and switches, emergency power system, or solar voltaic systems that electricians face while performing their tasks. Electric hazard gloves are rated by section 70E of the National Fire Protection Association (NFPA) and are classified by the amount of energy a worker may be exposed to if shocked. Electrical-insulating gloves and protectors are made of dielectric materials to protect workers from electrical shock. Electricians working on power lines wear rubber gloves (sometimes called lineman’s gloves). Leather protectors are worn over rubber gloves to protect against pinholes or punctures that can damage rubber gloves. Electrical-insulating glove kits include rubber gloves and leather protectors together. Work on energized electrical equipment would be a variance to the requirement for cut-resistant gloves that contain metal.

### *Other Types of Gloves*

- » General purpose: jersey, canvas, or string knit
- » Driver’s gloves: thin leather for general-purpose use
- » Leather palmed: durable cotton or canvas with leather palms and/or fingers. Available lined for cold-weather use.
- » Heat-resistant: flame resistant, high heat resistant, convection resistant, or a combination of all three. Generally, the best contain Carbon-X™ fibers as they are thin, comfortable, and allow for extra dexterity.
- » Welding: leather with heat-resistant panels. MIG and TIG models as well as thinner gloves for different types of welding or small piece welding.
- » Mechanics’ gloves: hybrid and composite materials. Some have grip layering or patterns for handling materials and come in fingered and fingerless styles.

### *Care of Protective Gloves*

1. Inspect before each use
  - a. Ensure they are not damaged and do not have tears, punctures, or cuts in the material
2. Gloves that are discolored or stiff may indicate degradation by UV rays, heat, chemical exposure, moisture, or extreme cold.
  - a. Be aware that leather gloves are prone to drying out and cracking, especially if left out in the sun or in hot environments
3. Gloves should not be altered, i.e., by cutting out the fingertips to provide additional dexterity or so one can use phones, tablets, etc.
4. Damaged gloves must be discarded. Discard and replace gloves as needed.



### Training

Workers must be trained based on the type and use of the gloves they are issued. Training must include inspection and care of the gloves, and workers must be able to demonstrate that they understand the rationale for the specific gloves they have been issued.

Workers must also understand that the gloves they are assigned must fit properly and function to meet their task assignments.

No worker should be assigned a task before the appropriate glove is assigned to them. Workers must understand that hands must be covered and protected at all times.

Additional training includes:

- » When to wear
- » What to use
- » How to select size
- » How to wear
- » Limitations
- » Proper care, inspection, maintenance, useful life, disposal, and replacement
- » Updates, changes for selection and use

**SIZING**

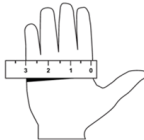

With a ruler, measure the width of your hand at the knuckle area.

2 - 2.5 Inches	Size 6	XS
2.5 - 3 Inches	Size 7	S
3 - 3.5 Inches	Size 8	M
3.5 - 4 Inches	Size 9	L
4 - 4.5 Inches	Size 10	XL
4.5 - 5 Inches	Size 11	XXL

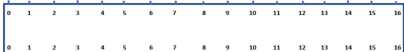

### Warehouse Availability

Alberici has a wide range of gloves and glove providers available to project teams, including gloves for the following:

1. Impact: primarily for heavy industrial or automotive
2. Cut-resistant level 4: for all general work activities
3. Leather: for steel erection if cut-resistant level 4 or greater
4. Coated: Water and chemical resistance
5. Hot work and welding gloves

Contact the warehouse if gloves are needed for specific tasks and exposures and are not stocked. They have the capability to access many sources and can generally obtain what you need in 24-48 hours. Some glove styles or sizes have longer lead times; be aware and make your selection known early.

Decisions for any gloves should be made on cost, dexterity, and in some cases, touchscreen technology. For further information, contact EWM or your safety leadership team.



## PROCESS SAFETY MANAGEMENT

The purpose of this Alberici procedure is to provide methods to determine and disseminate safe work practices related to contractor-specific work at facilities requiring process safety management (PSM). The purpose of the PSM standard is to prevent or minimize the consequences of catastrophic releases of toxic, reactive, flammable, or explosive chemicals in every environment in which we work.

### References

OSHA Standards 29CFR1910.119 and 29CFR1926.64

### Responsibility

The facility owner is responsible for developing a PSM plan that identifies potential hazards inherent to the facility processes.

The site manager or their designee shall have responsibility for obtaining a copy of the facility PSM plan and implement it sitewide as it applies to Alberici employees and subcontractors. The site manager shall ensure that each employee is trained in the work practices necessary to perform their job safely and in accordance with the facility's PSM procedures.

If Alberici works in a facility that is required to have a PSM, Alberici will inform employees of the PSM plan during orientation and periodically during the project through Toolbox Talks and SafeCard meetings.

Employee responsibilities during a PSM emergency shall be posted throughout the project site and detailed in a AHA before beginning work at the facility.

### Definitions

- » **Catastrophic Release:** a major, uncontrolled emission, fire, or explosion involving one or more highly hazardous chemicals that present serious hazards to employees in the workplace
- » **Hazardous Chemical:** any chemical that presents physical or health hazards
- » **Hot Work:** work involving electric or gas welding, cutting, brazing, or similar flame- or spark-producing operations
- » **Safety Data Sheet:** written or printed material concerning a hazardous chemical that is prepared in accordance with Hazardous Communication Standard, OSHA Standard § 1910.1200(g)

### Program Requirements

Under OSHA's PSM standard, certain facilities are required to develop operating procedures that provide clear instructions for safely conducting activities involved in each covered process consistent with the process. This includes initial startup, normal operations, normal shutdowns, and startup following turnaround or emergency shutdown.

Process safety information shall include the facility's plan and any subsequent information related to the process, including Safety Data Sheets for products related to these processes.

The process safety plan shall also include an emergency action plan to be implemented in the event of catastrophic fire, explosion, or toxic release.



## **Training**

Each employee shall be trained on safe work practices and operating procedures necessary to perform their work related to and covered under the facility's PSM policy or procedure. The training shall include safe work practices to provide for the control of hazards during operations such as lockout/tagout; confined space entry; opening process equipment or piping; and control over entrance into a facility by maintenance, contractor, laboratory, or other support personnel. These safe work practices shall apply to all employees directly employed and or subcontracted.

## **Documentation**

Written documentation shall be maintained at the site demonstrating that training in the known potential of fire, explosion, or toxic release hazards related to each employee's job and the process and applicable provisions of the emergency action plan has been received and understood by each employee. The documentation shall contain the identity of the employee, the date of training, and the means used to verify that the employee understood the training.

All hot work conducted on facilities covered by the PSM standard shall require the issuance of a hot work permit, in accordance with the facility's PSM procedure. No hot work shall be performed until the hot work permit is obtained. The permit shall document that the provisions of the OSHA Standard 29CFR1926.352 (Fire Prevention contained in Subpart J) have been met.

## **Incident Investigation**

Employees must immediately report all injuries and near misses. An incident investigation must be initiated upon notification of the site manager within no more than 48 hours. Resolutions and corrective measures must be documented and maintained for five years on any project covered under the PSM standard.

It is our responsibility to advise our client of any unique hazards presented by Alberici's work or of any hazards found by Alberici while working.

## **Trade Secrets**

Any trade secret information released to Alberici under the PSM standard shall remain confidential.



## PUBLIC AND UTILITY PROTECTION

OSHA regulations do not address protecting the public on project sites. The activities of most construction projects, however, can present serious and significant exposures to pedestrians and vehicles.

Besides protecting employees and our subcontractors, Alberici has a reasonable responsibility to provide a project site that is free of recognizable hazards that have caused or are likely to cause possible exposures or loss to the public.

### Public Liability Safety

In accordance with the needs of the owner during construction activities, some mandatory public liability safety work rules have been established that should help reduce incidents involving the public. They are:

- » All traffic signs or devices used for protecting the public shall conform to the current edition of the MUTCD published by the Federal Highway Administration (FHWA) and the project state's Manual of Uniform Traffic Control Devices for Streets and Highways, whichever offers the greatest degree of safety.
- » Barricades, cones, and/or similar protective devices shall be used when employees or the public are exposed to traffic or similar hazards. Hard physical barricades are almost always better than warning tapes.
- » When traffic patterns are closed or altered due to work activity, instructional or warning signs shall be used.
- » Flaggers shall be properly trained in the procedures for safely moving and processing vehicle traffic around construction activities.
- » Employees and subcontractors shall wear high-visibility clothing whenever exposure to moving vehicles or equipment is identified. This includes but is not limited to:
  - Working in a road closure, even when protected by temporary or permanent traffic control devices
  - Working near or around moving construction equipment
  - High-visibility equipment will conform to the applicable ANSI Standard.
- » Whenever and wherever possible or necessary, low-voltage (12-volt) protected lights shall be used to mark fences and barricades and other such encroachments onto public streets or sidewalks. These lights shall be kept operational.
- » Covered sidewalks shall be equipped with permanent lights to provide sufficient illumination for safe use by the public. All bulbs will be cage-protected and kept operational.
- » Public walkways and roadways shall be kept clean and free of construction-related hazards or materials.
- » Public walkways shall have abrasive, non-slip surfaces.
- » When steel plates, wood planking, or similar covers are used on public ways to cover excavations, they will be substantially secured to prevent movement from the flow of traffic.
- » When such covers are located where there is pedestrian traffic or exposures, they shall be tapered on all sides with cutback, cold mix, or similar material to eliminate tripping hazards. Covers will have a non-slip surface.
- » Whenever sidewalks or other normal pathways for pedestrians are blocked due to construction



activities, pathways that protect pedestrians from traffic or other hazards shall be provided around the blocked zone.

- » When work is to be performed over or near roadways, walkways, or other areas used by the public, adequate protection shall be taken to prevent material from falling on persons or vehicles. Employees will be instructed on the proper methods to be used for discarding rubbish and debris.
- » When trash chutes and Dumpsters are to be used for rubbish and debris disposal (from upper floors), such chutes and Dumpsters shall not be located near roadways, walkways, or other areas used by the public.
- » Construction materials that might be blown or swept off roofs or floors shall be properly secured and shall not be staged or stored near roof or floor perimeters.

### Employee Training

The project manager shall ensure that all existing and new employees are properly trained on these regulations. Training shall be documented.

*Employees must be made aware that violations of these safety rules or conduct that might jeopardize the safety of the general public will not be tolerated and will result in disciplinary action (including termination).*

### Responsibility and Authority

The project superintendent shall be assigned the responsibility and have the authority to ensure all good safety practices are followed.

### Utilities Identification and Protection Introduction

Alberici or any trade partners shall be required to identify, locate, arrange for removal of, and protect any utilities that might interfere with work to be performed.

#### Private Utilities

In general, many existing buildings and facilities contain utilities that may be hidden and require identification. Utilities installed on private property are NOT covered under the local one-call system. We must determine the location of these utilities before the start of any construction work. **Do not** depend on drawings to indicate the correct location of utilities. The contractor shall consult with the owners, construction managers, utilities, and architects (as necessary) to identify and locate these utilities.

#### Public Utilities

Because the contractor or owner does not control public utilities, these utilities can be installed, removed, relocated, activated, or deactivated without contractor knowledge that these activities ever occurred. Therefore, it is essential that the location of these items be determined prior to the start of any work. The contractor shall locate public utilities by either consulting with the individual utility company or calling the utility protection center.

#### Protecting Utilities

Once identified and located, the contractor/subcontractor shall take the utmost care to protect utilities from damage. The contractor shall:

- » Use hand or controlled mechanical excavation procedures for underground utilities When within 3 feet of any buried utility



- » Shore, support, brace, or reinforce (as necessary) any exposed utility lines
- » Protect exposed utilities from weather and vandalism exposures, as necessary
- » Clearly mark or identify any exposed utilities and provide appropriate warning or danger signs as needed to protect employees, the public, and the utility itself
- » If possible, de-energize and lock out the utility when locating it or working near it

### **Notification**

At least three working days (72 hours) before breaking ground or performing work that will affect overhead or buried utilities, the contractor/subcontractor shall notify in writing the owner, construction manager, all public utility companies, and any persons having property, structures, or improvements near the work area.

*No work shall be performed until all parties have been contacted and all utilities properly located and marked. Failure to comply may cause significant property damage, serious injury, or death.*

### **Responsibility and Authority**

The Alberici project manager shall ensure that all utility coordination and location activities are properly accomplished before starting any work. The Alberici project superintendent shall be responsible to ensure the safe excavation, protection, and restoration of all utilities.

### **Subcontractor Exposure**

It is essential that we protect the work, equipment, and employees of others on site, including our subcontractors. In addition, we must insist that subcontractors protect others in the area.

### **Equipment**

When we move equipment in and out of a project site, it may be necessary to reroute traffic to maneuver or park our vehicles. This activity should be coordinated with the local police and fire departments, as necessary. Traffic control signs and barricades should be properly placed and maintained with lighting if they are to be used after dark.

Flaggers should be equipped with highly visible, reflective vests, stop signs, and other equipment as needed. Flaggers should be trained in traffic control and should be able to deal with the public in a diplomatic manner. Training should be documented.

### **Property of the Owner and Others**

It is essential that we make every effort to prevent damage to the existing property of the owner or others while performing our work. In the event there is damage, the project manager will be immediately notified of the incident and report it to risk management.



## RESPIRATORY PROTECTION PROGRAM

Effective program administration includes:

- » An assessment to determine the nature and degree of actual or potential exposure
- » Respirator selection using the guidelines set forth by the American Industrial Hygiene Association or by another decision logic system
- » Employee training
- » Respirator fitting
- » Maintenance, cleaning, and storage
- » Purchasing and inventory control
- » Emergency use planning
- » Medical surveillance
- » Program evaluation

Projects anticipating the need for respiratory protection should contact the Safety Department for guidance regarding the procedures required and the necessity for following as outlined in OSHA 29CFR1926.103 and is identical to 29CFR1910.134.

If the project anticipates using respirators voluntarily, i.e., the use of filtering facepieces (dust masks), they must provide the information contained in Appendix D of the standard to their employees, but they do not need a written respiratory protection program in place.

### General

The OSHA General Industry Standard for Respiratory Protection 29CFR1910.134 requires that a respiratory protection program be established and administered by the employer. The procedures required by OSHA are outlined in this section.

### Guidelines

The guidelines in this program are designed to help reduce employee exposures against occupational dusts, fumes, mists, radon nuclides, gases, and vapors.

- » The primary objective is preventing personal exposures above the permissible exposure limit (PEL) to these contaminants.
- » Where feasible, exposure to contaminants will be eliminated by engineering controls (such as general and local ventilation, enclosure or isolation, and substitution of a less hazardous process or material). Administrative controls, such as job rotations, should also be considered.
- » When effective engineering and administrative controls are not feasible, use of personal respiratory equipment may be required to achieve this goal.

### Responsibilities

#### *Management*

It is management's responsibility to determine what specific applications require use of respiratory equipment. This determination is based on specific hazard identification, estimated exposure, and factors affecting respirator performance. Only National Institute for Occupational Safety and Health (NIOSH)-certified respirators that provide the required protection factors for the specific contaminants will be selected and provided to operational personnel. Employees shall be provided with appropriate training and instructions on all equipment.



### *Management/Supervisory*

Superintendents, supervisors, forepersons, or group leaders of each area are responsible for ensuring that their subordinates comply with all facets of the respiratory protection program, including respirator training, inspection, and maintenance. The training must be comprehensive, understandable, and recur annually, or more often if necessary. Training components must include respirator selection, use, limitations, capabilities, cleaning, maintenance, inspection, proper doffing and donning, and medical signs and symptoms that could interfere with the use of a respirator.

### *Employees*

Employees are responsible for knowing the respiratory protection requirements for their work area (as explained by management). Employees are also responsible for wearing the appropriate respiratory equipment according to proper instructions and for maintaining the equipment in a clean and operable condition. Employees shall:

- » Guard against damage to equipment
- » Report any malfunction of the equipment
- » Not borrow or use any respirator for which they have not been fit tested or use other equipment not assigned to them

### **Issuance of Respirators**

- » Medical approval is required for individual use of all respirators before fitting or issuance. During the physical examination, performed by a physician or other licensed health care professional (LHCP), there may be criteria which prohibit the wearing of respirators. They include:
  - Ruptured or perforated eardrums prohibit issuance of half-mask respirators.
  - Pulmonary or cardiac problems may prohibit issuance of half-mask respirators or use of SCBA or air-supplied full-face respirators.
  - Deficient olfactory sense must be noted.
- » Anyone with a beard, chin whiskers, or long sideburns will not be fit-tested to wear a half-mask or full-faced respirator.
- » Fitting of half-mask respirators (covering the nose and mouth only) is a requirement of ANSI standards and OSHA regulations governing use of respirators. Each employee must be fitted with the appropriate type of half-mask respirator. Fitting will be done by qualified personnel using appropriate test methods.
  - Fitting information will be recorded.
  - The properly fitted respirator will be issued and the make and model documented.
  - Records will be located in the Safety Department.
- » After an employee has been fitted with a half-mask respirator:
  - The correct respirator and appropriate cartridges for the task and hazard will be issued.
  - The respirator must be cleaned and properly stored at the end of each shift it is worn.
  - Cartridges must be replaced at the first indication of breakthrough, as evidenced by odor inside the mask. Cartridges used to protect against benzene must be changed at the end of the shift.

### **Nature of Hazard**

The following is a general guide for atmospheres containing specific contaminants (see Appendix A).

- » Oxygen-deficient atmospheres: Only self-contained breathing apparatuses or an airline respirator



supplied from cylinders shall be used in any atmosphere that is deficient in oxygen. For this procedure, any atmosphere that tests lower than the normal 19.5% of oxygen is considered to be oxygen deficient.

- » Immediately dangerous to life and health (IDLH) atmospheres: Only self-contained breathing apparatuses or supplied-air masks shall be used in atmospheres where gases are present in concentrations that would rapidly endanger a person.
- » It is not Alberici policy to require personnel to enter oxygen-deficient or IDLH atmospheres. If these conditions are present, contact a member of the Safety Department as soon as they are discovered.
- » Not immediately hazardous atmospheres: Chemical cartridge respirators shall be used for gaseous contaminants. Mechanical filter respirators shall be worn as protection against particulate matter.

### **Use of Respiratory Protective Equipment**

#### *Restrictions*

In areas where the user, with failure of the respiratory protective equipment, could be overcome by toxic or oxygen deficient atmosphere:

- » At least one additional person shall be present.
- » Communications—whether visual, voice, or signal line—shall be maintained.
- » A plan shall be implemented whereby one individual will be unaffected by any likely incident and have the proper equipment to be able to assist the other in case of an emergency without entering the work area.
- » Vessel entry is not permitted, even with appropriate respiratory equipment, in areas that test above 10% of the lower exposure limit (LEL).

### **Types of Respiratory Protective Equipment**

#### *Dust, Fume, and Mist Respirators*

- » Paper filter dust masks offer protection against low levels of airborne nuisance dusts but do not provide protection against mist, vapors, or metal fumes.
- » Air-purifying respirators (APR) that are MSHA-approved (can be paper filter mask) shall be used for mist, vapors, and metal fumes. Verify the mask is certified by NIOSH and is approved for the contaminant of concern.
- » APRs do not provide protection against gases, vapors, or oxygen deficiency.

#### *Air-Purifying Respirators (APR)*

- » APRs afford protection against concentrations of certain acid gases and organic vapors, utilizing various chemical agents to purify the inhaled air. They shall not be used in atmospheres that are oxygen deficient.
- » APR chemical cartridge (half-mask or full face) shall not be used for protection against:
  - Gaseous material that is extremely toxic in small concentrations (hydrogen, cyanide, and sulfide)
  - Exposure to harmful gaseous material that cannot be detected by odor (carbon monoxide)
  - Gaseous material in concentrations that are highly irritating to the eyes



### *Air-Supplied Hood*

- » The air-supplied hood is normally used where the user only requires protection against levels of material or airflow for cooling purposes and shall not be used in any situation where the user would be endangered by airborne contaminants.

### *Airline Respirator*

- » The airline respirator consists of a full-face mask supplied with breathing air by a compressor or multiple stationary cylinders.
- » The airline respirator will provide protection in any atmosphere regardless of the degree of contamination.
- » Whenever an airline respirator is issued in an IDLH atmosphere, a rope shall be attached to the harness, and standby persons shall be present with rescue equipment. A five-minute escape pack shall also be provided to the employee.
- » Care must be exercised to prevent damage to the hose and regulator while in use, and the assembly shall be stored in such a way that damage will be avoided.

### *Cylinder-Type Self-Contained Breathing Apparatus*

- » The self-contained breathing apparatus uses compressed breathing air and will provide respiratory protection in any atmosphere regardless of contamination or level of oxygen.
- » When anticipating the use of this apparatus, consideration shall be given to the life of the cylinders. Although this equipment should provide breathing air for approximately 30 minutes, excessive physical work, emotional stress, and other factors will reduce the rated time.
- » Users of this equipment shall immediately begin exiting the hazardous atmosphere when the low-pressure alarm sounds. A five-minute escape pack shall also be worn by the employee.
- » Whenever compressed air apparatus is used in an atmosphere immediately dangerous to life, standby persons shall be present with suitable rescue equipment.

## **Maintenance and Care of Respiratory Protective Equipment**

*For selection of respiratory equipment and appropriate personal protective equipment (PPE), consult the safety data sheet (SDS for the contaminant concern).*

### *Inspection for Defects*

- » All respiratory protective equipment shall be inspected routinely before and after each use.
- » Spare breathing air cylinders shall be maintained at a minimum of 1800 pounds pressure except when depleted during use. (OSHA states air and oxygen cylinders should be maintained in a fully charged state and be recharged when the pressure falls to 90% of the manufacturer's recommended pressure level. Looking up 30-minute cylinder pressure levels, that'd be 2,216 psi for fully charged, making 90% of that 1,994.4 psi) The regulator and any warning devices shall be tested during inspections to determine whether they function correctly.
- » Inspection of equipment shall include a check of the tightness of connections.
- » Equipment that is not routinely used but is kept ready for emergency use shall be inspected after each use and at least monthly to ensure that it is in satisfactory working condition. Each applicable project shall complete an emergency respiratory protective equipment monthly inspection report shall forward a copy to the Safety Department by the last day of the month.



### *Cleaning of Respiratory Protective Equipment*

- » The wearer shall clean and inspect equipment issued for routine use after each day's use.
- » Users shall clean and disinfect equipment maintained for emergency use after each use.

### *Repair of Respiratory Protective Equipment*

- » Alberici shall ensure that respirators that fail an inspection or are otherwise found to be defective are removed from service and are discarded, repaired, or adjusted in accordance with the following procedures:
  - Repairs or adjustments to respirators are to be made only by persons appropriately trained to perform such operations and shall use only the respirator manufacturer's NIOSH-approved parts designed for the respirator.
  - Repairs shall be made according to the manufacturer's recommendations and specifications for the type and extent of repairs to be performed.
  - Reducing and admission valves, regulators, and alarms shall be returned to the manufacturer or a technician trained by the manufacturer.

### *Storage of Respiratory Equipment*

- » Respiratory protective equipment shall be stored to protect against dust, sunlight, heat, extreme cold, excessive moisture, or damaging chemicals.
- » Respiratory protective equipment placed in a work area shall be stored in clearly marked compartments that are quickly accessible at all times.
- » Respiratory protective equipment shall be packed or stored to prevent deformation of the facepiece and exhalation valve.
- » Respiratory protective equipment shall not be stored in places such as lockers or toolboxes unless the equipment is protected in cases or cartons.

To ensure an effective respiratory protection program, Safety Department representatives will monitor and evaluate various operations to ensure that respiratory protective equipment is properly selected, used, cleaned, and maintained. Anyone desiring assistance with this procedure should contact the Safety Department.

### **Fit Testing of Respiratory Devices**

After the medical assessment is complete, employees using a tight-fitting respirator shall pass an appropriate QLFT or QNFT prior to initial use of the respirator, whenever a different respirator facepiece (size, style, model or make) is used, and at least annually (or as required by the applicable jurisdiction) thereafter.

Fit testing shall be performed using the same make, model, style and size of respirator the user would be expected to use.

Should the fit test fail, alternative makes, models, styles and sizes shall be tested to find a correct fit for the user.

Respiratory protective equipment shall not be used unless a satisfactory fit test has been achieved for that equipment.

Fit testing shall also verify user competency in donning, doffing, inspecting and performing seal



checks.

Additional fit tests will be performed:

- » Whenever there is an indication that changes in the employee's physical condition might have an effect on respirator fit (such conditions include, but are not limited to, facial scarring, dental changes, cosmetic surgery, or an obvious change in body weight)
- » If the employee notifies their supervisor or safety manager that the fit of their respirator is unacceptable.

### **Procedure for Using a Multipack Breathing System: 12-Pack/Six-Pack/Two-Pack Description**

Typically, a system can be modified to each circumstance. We will assemble a two-pack system (generally an assembly of a two-pack will be sufficient) using a two-wheeled mobile hand truck.

Each of the cylinders will contain 220 cubic feet of breathing air connected by a manifold and mounted on the bottles. Each cylinder contains breathing air that has been filtered for breathing purposes at approximately 2200 PSIG when full. The manifold has two outlets that pass through a low-pressure alarm and regulator to supply air at 80 PSI for use with pressure-demand airline-breathing equipment.

Procedure for use:

1. Open all cylinder valves to the manifold
2. Slowly open the main air valve fully to the regulator
3. Check regulator gauges. A newly filled system, regardless of the number of bottles the system has, should have approximately 2200 PSIG on the high- pressure side and approximately 80 PSIG on the low-pressure side. For proper operation, 80 PSIG on the low-pressure side is the required supply pressure. A pressure relief valve incorporated into the system is present at 100 PSI; in the unlikely event of regulation failure, it will vent excessive pressure of air to the atmosphere.
4. The breathing air hose from the belt regulator is then connected to the air supply system at one of the two low-pressure outlets. Airflow should not flow from the supply system to the belt regulator to the mask.
5. When the air pressure on the bottles reaches 500 PSI, close all the cylinder valves and the main valve; mark the bottles with a tag "MT" and return the bottles for refilling.

### **Airline Hose**

Before connecting the airline hose to the breathing air station, inspect the length of the hose for:

- » Cleanliness
- » Cracks or other damage
- » Fittings for condition

Airline hose must be loosely coiled and stored in a clean, dry area.

### **Airline Mask**

Before using a pressure demand air mask:

1. Visually check the unit to ensure all components are in place and in good condition. Make sure all components on facepiece are secure.
2. Check the breathing tube for cracks or other damage
3. Make sure all harness straps are fully extended, buckles are not connected, and hoses are not tangled
4. Put the shoulder strap over the right shoulder and fasten the waist strap around the waist. Adjust



the harness assembly, ensuring it provides a snug and comfortable fit while also ensuring that the point where the breathing tube is attached is readily accessible to both hands.

5. Adjust the five facepiece head straps to their full outward position
6. Place the neck strap around back of neck
7. Using the quick coupler, connect and lock the demand valve hose to the air hose assembly that goes over the shoulder

### **Information for Employees Using Respirators When Not Required Under the Standard**

An employer may provide respirators at the request of employees or permit employees to use their own respirators if the employer determines that such respirator use will not in itself create a hazard. If the employer determines that any voluntary respirator use is permissible, the employer shall provide the respirator users with the information contained in Appendix D to this section (Information for Employees Using Respirators When Not Required Under the Standard) This information should be provided to the employee, and documentation that the information has been received and reviewed must be kept by the project and a copy forwarded to the Safety Department.

### **Appendix D to Sec. 1910.134**

(Mandatory) Information for Employees Using Respirators When Not Required Under the Standard  
Respirators are an effective method of protection against designated hazards when properly selected and worn. Respirator use is encouraged, even when exposures are below the exposure limit, to provide an additional level of comfort and protection for workers.

However, if a respirator is used improperly or not kept clean, the respirator itself can become a hazard to the worker. Sometimes, workers may wear respirators to avoid exposures to hazards, even if the amount of hazardous substance does not exceed the limits set by OSHA standards. If your employer provides respirators for your voluntary use, or if you provide your own respirator, you need to take certain precautions to be sure that the respirator itself does not present a hazard.

You should do the following:

1. Read and heed all instructions provided by the manufacturer on use, maintenance, cleaning and care, and warnings regarding the respirator's limitations.
2. Choose respirators certified for use to protect against the contaminant of concern. NIOSH, the National Institute for Occupational Safety and Health of the U.S. Department of Health and Human Services, certifies respirators. A label or statement of certification should appear on the respirator or respirator packaging. It will tell you what the respirator is designed for and how much it will protect you.
3. Do not wear your respirator into atmospheres containing contaminants for which your respirator is not designed to protect against. For example, a respirator designed to filter dust particles will not protect you against gases, vapors, or very small solid particles of fumes or smoke.
4. Keep track of your respirator so that you do not mistakenly use someone else's respirator (63 FR 1152, Jan. 8, 1998; 63 FR 20098, April 23, 1998).



## SCAFFOLD PROCEDURES

Scaffolds and other elevated work platforms can expose workers to falls and falling objects if appropriate safety measures are not implemented. Scaffolds should be built using either the manufacturer's recommendations, plans designed by a registered Professional Engineer, or following the OSHA standards for the scaffold being built. Trained erectors and dismantlers shall build all scaffolds, and a competent person shall witness either the erection activities, dismantling activities, or alterations to the scaffolding. Prior to initial use and daily, the scaffolding shall be inspected by a competent person.

All scaffolding is required to be designed by a qualified person and must be erected in accordance with that design. All working levels of scaffolds are required to be fully planked or decked between the front uprights and guardrail supports in the back.

General rules apply to maintaining all types of scaffolds in safe, working condition.

- » No scaffold should be erected, moved, dismantled, or altered except under the supervision of a competent person.
- » The structure should be cleared of all rubbish daily. No tools should be left on scaffolds overnight.
- » No excess materials should be stockpiled on scaffolding. Discussion of "excess material" should take place prior to the scaffold use to clarify any confusion.
- » Notices regarding the use of scaffolds should be conspicuously displayed when needed.
- » Scaffold structures should be protected from being struck by trucks and other vehicles.
- » Working platforms should be free of ice, snow, oil, and other elements.
- » No open fires are permitted on or near scaffolds.
- » Guardrails are required on all sides and ends of all scaffolds.
- » Personal fall arrest systems are required for each employee in a boatswain's chair, catenary scaffold, and float scaffold when the employee is 6 feet or more above floor level. Fall arrest systems may be required when conditions indicate they are needed.
- » Fall protection is required for each employee on a scaffold at 6 feet or higher above floor level. Fall protection must be used if ladders are used on scaffolds, and the ladders must be properly secured.

### Tags

- » **Danger (Red):** Applied to all scaffolds being erected, dismantled, or altered. Access to these scaffolds is limited to the erectors or dismantlers only, and fall protection is mandatory for fall hazards greater than 6 feet.
- » **Caution (Yellow):** Applied to all scaffolds that are incomplete in some regard, i.e., missing guardrails on one or both ends or having a hole in the platform where piping will be placed. Employees will be directed on the tag that fall protection is required because of the scaffold's being incomplete.
- » **Passed Inspection (Green):** Applied when the scaffold has been inspected and has been found to be fully planked or decked, proper top rail, midrail, toe board, and proper access ladder.

### Inspections

Scaffolds shall be inspected by a competent person daily ([Scaffold Inspection Checklist](#)). The inspection shall be documented. Each employee who erects, dismantles, repairs, maintains, moves,



inspects, or works from scaffolds of any type is required to be trained by a person “qualified in the subject matter.” Training is to be completed before employees are assigned to perform the assigned work.

### **Training**

- » The nature of any fall hazards, electrical hazards, and falling-object hazards in the work area
- » The correct procedures for dealing with electrical hazards and for erecting, maintaining, and disassembling the fall protection system and falling-object systems being used.
- » The proper use of the scaffold and proper handling of materials while on the scaffold
- » The maximum intended load and load-carrying capacity of the scaffold
- » Any other applicable information (i.e., employees must comply with tag system)

Training for those who erect, disassemble, move, operate, repair, maintain, or inspect scaffolding includes:

- » The nature of scaffold hazards
- » The correct procedures for erecting, dismantling, moving, operating, inspecting, and maintaining scaffolds
- » The design criteria, maximum intended load-bearing capacity, and intended use of the scaffold
- » Any other pertinent information
- » Scaffold erectors and scaffold users are required to be retrained when:
  - » Changes affect the types of scaffolds, fall protection, falling object protection, or other equipment or procedures related to the hazards associated with site scaffolding.
  - » Changes in the worksite present new hazards to which the employee has not been previously trained.
  - » An employee demonstrates a lack of skill or understanding or where inadequacies in an affected employees’ work involving scaffolds indicates that the employee has not retained proficiency.

### **Inspections**

Competent persons shall inspect the scaffold prior to use, document the inspection, and report any defects or concerns to their Supervisor immediately. Scaffolds and scaffold components shall be inspected for visible defects by a competent person prior to initial use, before each work shift, and after any occurrence which could affect a scaffold’s structural integrity.

### **General Rules for Scaffold Design**

- » Each scaffold should be capable of supporting four times the maximum intended load, including workers, building materials, and the weight of the scaffold structure itself.
- » Adequate support, such as planks (mudsills), should be provided under uprights, especially when they rest on earth, sand, or loose material. Cross-bracing to provide stability should also be provided.
- » Ladders or stairs should be provided to safely access the scaffold. The ladder or stairs must be secured to the scaffold.
- » Ladder selection and design should be in accordance with manufacturer’s recommendations.
- » Guardrails, midrails, and toe boards should be provided on all open sides of working platforms.
- » Appropriate wire mesh screening should be provided between the top guardrails and toe boards



when there is a falling object hazard and personnel working below.

### *Tubular Steel Scaffolding*

- » Steel scaffolding should be erected and used in accordance with the manufacturer's and/or professional registered engineer's recommendations under the supervision of a competent person.
- » Proper seating and locking of all connections, with the correct devices, is mandatory. Parts should not be mixed.
- » Firm footing should be provided for each upright. Footing or anchorage should be sound, rigid, and capable of carrying the maximum intended load without settling or displacement.
- » All uprights should be plumb, secured, and rigidly braced to prevent swaying and displacement. Cross-bracing is required at every other section as a minimum.
- » Platforms should be constructed of 2 10 scaffold-grade wood planks or equivalent. All planking of platforms should be overlapped by a minimum of 12 inches or secured from movement.
- » Toe boards are designed to guard against falling objects. Toe boards should be installed on all open sides and ends of platforms more than 10 feet above the ground when workers are working or have access underneath. Toe boards should be at least 4 inches in height.
- » Guardrails should be provided on scaffolds to prevent falls. Guardrails should be 42±3 inches high and should have a midrail. Guardrails should be supported at 8-foot intervals or less. Falling object protection, such as mesh screen, shall be installed between guardrails and midrails when workers will be walking or working under scaffolds.
- » Uprights should be erected and maintained in a vertical (plumb) position, and appropriate diagonal or cross-bracing should be provided for uprights. All brace connections should be made secure.
- » Scaffolds should be secured to the building or structure at intervals not to exceed 30 feet horizontally and 26 feet vertically.

### *Rolling Scaffolds*

- » The height of mobile scaffolds should not exceed four times the minimum base dimension.
- » Casters should support four times the maximum intended load.
- » Mobile scaffolds should be properly braced with cross-bracing and horizontal bracing.
- » Platforms should be tightly planked.
- » A ladder must be provided for proper access and exit.
- » Mobile scaffolds should be moved by applying force as close to the base as practicable. All tools and equipment on the scaffold should be removed or secured before the scaffold is moved.
- » Workers should not ride on mobile scaffolds while they are being moved. If workers must remain on the scaffold, they must stop work, squat below the top rail of the scaffold and hold onto the scaffold with both hands while the scaffold is in motion.
- » Scaffolds in use should rest on stable footing and should be plumb.
- » All casters or wheels must be locked once a scaffold has been placed. Workers on the scaffold are not allowed to move themselves on the scaffold.
- » Mobile scaffolds should be equipped with guardrail, midrail, and toe boards.



### *Wood Scaffolding*

- » All lumber used in constructing ramps, platforms, staging, and scaffolding should be good quality, seasoned, and straight-grained.
- » All lumber should be free of large, loose, or dead knots and other defects, which could decrease the structural integrity of the lumber.
- » All lumber should be scaffold-grade. Note: OSHA does not approve scaffold lumber. If purchasing or using lumber designed for scaffold use, the lumber may be stamped “OSHA Compliant.”
- » All nails should be driven in completely. Nails should not be subjected to direct pulls. A minimum of four nails per joint should be used.

### *Outrigger Scaffolds*

- » Outrigger beams should extend no more than 6 feet beyond the face of the building.
- » The inboard end of the outrigger beams should not be less than 1½ times the outboard end in length from the fulcrum point to the anchorage point.
- » The beams should rest on the edge.
- » The sides should be plumb.
- » The edges should be horizontal.
- » The fulcrum point should rest on a secure bearing at least 6 inches in each horizontal dimension.
- » The beam should be secured in place against movement.
- » The beam should be braced at the fulcrum point against tipping.
- » The inboard ends of outrigger beams should be properly secured. Counterweights should be specifically designed as counterweights and will not be sandbags, roofing material, masonry units, or other materials.
- » Outrigger scaffolds should be designed by a qualified professional engineer or in accordance with OSHA’s scaffolding standard.
- » Planking should be laid tight.
- » Suspension ropes will be inspected daily by a competent person. The inspection shall be documented.
- » Planking should extend to within 3 inches of the building wall and secured to beams.
- » Appropriate guardrails, midrails, and toe boards must be attached.

### *Suspension Scaffolds*

- » All supporting parts should be inspected before each installation. Daily inspections should be conducted during use. The inspections shall be documented.
- » Suspension scaffolds designed for a working load of 500 pounds should be limited to two workers at any one time.
- » Suspension scaffolds with a working load of 750 pounds should be limited to three workers at any one time.
- » Workers must always use required lifelines and safety harnesses.
- » Suspension scaffolds should be securely lashed to the building or structure to prevent swaying.
- » Suspension scaffold platforms should be of the ladder type, plank type, beam type, or light-metal type and should meet all appropriate design requirements.



- » Appropriate guardrails, midrails, and toe boards should be provided.
- » Platforms should not be less than 20 inches or more than 36 inches wide.
- » Platforms should be securely fastened to the hangers by U-bolts or equivalent.
- » Hangers should be made of mild steel or equivalent and capable of sustaining four times the maximum rated load at the cross-sectional area.
- » Hoisting machines should be listed by Underwriters' Laboratories or Factory Mutual Engineering Corporation.
- » Roof irons or hooks should be of mild steel or equivalent and of proper size and design. Attachment points should be in good condition and inspected daily.
- » Appropriate and properly installed tiebacks should be provided to serve as a secondary means of anchorage.
- » Suspension should be accomplished with wire or synthetic or fiber ropes capable of supporting at least six times the rated load.
- » The sheaves of all blocks consisting of at least one double and one single block should fit the size and type of rope used.
- » Power units and manually operated winches should be tested and listed by Underwriters' Laboratories or Factory Mutual Engineering Corporation.

#### *Ladder Jack Scaffolds*

Generally, ladder jack scaffolds are not permitted on Alberici work sites, except in cases where there is no other way available to perform the work. In that case, the Safety Department must be contacted for assistance in developing a procedure for use of this type of scaffold.

Some basic requirements are:

- » Ladder jack scaffolds are limited to light duty work (less than 200 lbs.).
- » Maximum working height should not exceed 20 feet.
- » Ladders used in conjunction with ladder jack scaffolds should be heavy-duty and meet ANSI A14.1 and A14.2 ladder requirements. Referenced standards are available.
- » Cleated ladders should not be used.
- » Ladder jacks should bear on side rails, and ladder runs or bearing area on rungs should be at least 10 inches.
- » Ladders should be secured to prevent slipping.
- » Wood platform planks should be at least 2 inches thick.
- » All platform planks should overlap at least 12 inches.
- » Platform width should be at least 18 inches.
- » The span between supports for wood platforms should not exceed 8 feet.
- » No more than two workers should occupy any given 8 feet of a ladder jack scaffold.
- » Guardrails or other suitable fall-protection devices are required.

#### *Inspection*

Scaffold users shall read scaffold tags prior to using any scaffold. The instructions or warnings outlined on the tag must be followed.



### Example Scaffold Tags

Red Scaffold Tag	Green Scaffold Tag	Yellow Scaffold Tag
<ul style="list-style-type: none"> <li>Scaffold has not passed inspection by a competent person</li> <li>Not safe to use.</li> </ul>	<ul style="list-style-type: none"> <li>The competent person has inspected; and</li> <li>Approved the scaffold for use.</li> </ul>	<ul style="list-style-type: none"> <li>Scaffold does not meet OSHA specifications</li> <li>Personnel working on the scaffold must use approved fall protection.</li> <li>A possible improvement to the yellow tag currently being used and displayed below would be to have a place on the tag to specifically describe the deficiency.</li> </ul>

### Stilts

- » Stilt use falls under the scaffold standard and are allowed in rare circumstances on Alberici projects. Because of the additional height above ground and the lack of flexibility, stilt wearers are prone to serious injury as a result of falling or knee and other strains because of the awkward and unnatural body positioning.
- » An employee may wear stilts on a scaffold only if it is a large area scaffold.
- » When an employee is using stilts on a large area scaffold where a guardrail system is used to provide fall protection, the guardrail system shall be increased in height by an amount equal to the height of the stilts being used by the employee.
- » Surfaces on which stilts are used shall be flat and free of pits, holes, and obstructions, such as debris, as well as other tripping and falling hazards.
- » Stilts must be properly maintained. Any alteration of the original equipment shall be approved by the manufacturer.
- » Michigan has specific criteria for stilt use under MIOSHA Construction Standards, part 12.
- » Be aware of the specific requirements and notify subcontractors of the policy. If subcontractors intend to use stilts to perform work must acknowledge that they will meet the requirements of this policy prior to beginning work.



## SILICA EXPOSURE PLAN

Understanding our work is essential to our company's success and the health and safety of our employees. The Occupational Health and Safety Administration (OSHA) implemented a revised Silica Standard in 2016 that significantly reduced the exposure to respirable silica dust to all workers ([Silica Exposure Plan](#)).

### Introduction

Silica, often referred to as crystalline quartz, is one of the earth's most common, naturally occurring minerals. It is found in rock, soil, and sand; therefore, many materials common on construction sites, including soil, sand, concrete, masonry, rock, granite, and landscaping materials, contain silica. There are three forms of silica – quartz, cristobalite, and tridymite. Quartz is most common and the least hazardous of the three forms; however, it is a known carcinogen.

The dust created by cutting, grinding, drilling, or otherwise disturbing these materials can contain crystalline silica particles. These dust particles are microscopic and cannot be seen. The respirable silica particles penetrate deep into the lungs and are 100 times smaller than ordinary beach sand. The primary route of entry is by breathing; therefore, we need to provide respiratory protection or a better method of protection through engineering and administrative controls. Respirable silica dust causes lung disease, lung cancer, and other illnesses. It takes only a minuscule amount of airborne silica dust to create a health hazard.

Recognizing that very small, respirable silica particles are hazardous, the Occupational Safety and Health Administration (OSHA) regulation 29 CFR 1926.1153 requires construction employers to keep worker exposures at or below a permissible exposure limit (PEL) of 50 µg/m<sup>3</sup> or comply with Table 1 – Specified Exposure Control Methods When Working with Materials Containing Crystalline Silica.

### Program Administrators

The management and control of the silica exposure plan is held by the Safety Department and field operations management.

### Competent Persons

Alberici will name project site competent persons with the capability of identifying existing and predictable hazards in the surroundings or working conditions that are unsanitary, hazardous, or dangerous to employees, and who have authorization to take prompt corrective measures to eliminate them. However, if a full-time dedicated safety representative is not on site on any project where exposure to respirable silica dust is possible, the project must identify, by name, on the applicable AHA who will be that project's competent person. If activities or assignments change the project-specific competent person must be identified each time.

### Responsibility and Identification of Tasks

Alberici performs work that exposes workers to respirable silica dust. Alberici and each project is responsible for identifying specific tasks that create that exposure. The primary method is to use OSHA's Table 1 to determine activities that create respirable silica dust. If a project has or uses these materials, there is likely to be silica exposure.

Alberici's focused self-performed tasks that fall under this program may include housekeeping/sweeping of the job site, grinding concrete, general modification of poured concrete, patching concrete, and site maintenance. Any additional tasks that arise will be assessed and controlled via this program and Table 1 provided in the standard (attached to this plan). All tasks referenced will



follow the engineer and work practice control methods as well as the required respiratory protection and minimum assigned protection factors methods outlined in Table 1.

All subcontractors will be expected to adhere to the requirements of the OSHA standard and communicate the tasks and silica control measures for their tasks prior to start.

Below is a list of construction materials that could contain silica as well as a list of tasks that are controlled via the standard’s table below. A full table is attached to this plan.

Asphalt (for paving)	Fiber cement products	Refractory mortar or castables	Stucco, EIFS
Brick	Grout	Refractory units, sand	Terrazzo
Cement	Gunite or shotcrete	Rock	Tile, including clay, ceramic, concrete, etc.
Concrete	Mortar	Roofing tiles, pavers	
Concrete block	Paints containing silica	Soil, including fill dirt and topsoil	
Drywall	Plaster	Stone, including granite, limestone, quartzite, sandstone, shale, slate, cultured	

A project that has these tasks will have silica exposure.

Abrasive blasting	Earthmoving	Polishing	Scarifying
Bush hammering	Grinding	Roofing	Scraping
Cutting/sawing	Jackhammering	Sacking/patching	Sweeping/cleanup
Demolishing/disturbing	Milling	Sanding	
Drilling	Mixing	Scabbing	

Alberici will assess their work and the work of their subcontractors to decide whether it falls into one or more of these activities and proceed appropriately. The directions and information included in Table 1 must be fully implemented (see below in Evaluation and Additional Information sections).

As part of our responsibility as the general contractor, prime contractor, and/or controlling contractor, Alberici must ensure that subcontractors also evaluate their work and establish an appropriate plan.

It is important to know that the standard only applies to workers “engaged in the task.” For example, An employee operating a jackhammer would be engaged in the task, but another employee directing traffic near the employee jackhammering would not be engaged in the task.

When Table 1 requires respiratory protection, employers must provide respirators to all employees engaged in the task. Employers must describe procedures for restricting access of employees not engaged in the task as part of its written exposure control plan, and Alberici must provide appropriate respiratory protection and control measures to those workers who are not directly engaged in the task but, because of wind conditions or work location, may have exposure to respirable crystalline silica dust.



Other activities beyond the above 18 tasks release respirable silica dust. For those identified tasks, alternative controls must be implemented.

### Implement Alternative Controls

Alternative exposure control methods must:

- » Determine the levels of respirable crystalline silica that employees are exposed to
- » Limit employee exposures to a PEL of 50 µg/m<sup>3</sup> of air as an eight-hour time-weighted average (TWA)
- » Use engineering and work practice controls, to the extent feasible, to limit employee exposures to the PEL and supplement the controls with respiratory protection when necessary
- » Keep records of employee exposure to respirable crystalline silica

This methodology is very detailed and each project that identifies additional tasks releasing respirable crystalline silica dust should contact the Safety Department and this program's administrators for additional information.

### Respiratory Protection

Table 1 contains tasks that require immediate respiratory protection and others that require respiratory protection after four hours of exposure per day. The primary respiratory protection method identified is a respirator with an APF (assigned protection factor) of 10. In most cases, this is a filter facemask air-purifying respirator, such as an N95 or N100. Alberici recommends using N100 filter face masks. It is important to remember that when respiratory protection is used 30 or more days per year, the company (Alberici or trade partner) is required to provide, at no cost to the worker, a medical evaluation including:

- » Medical and work history
- » Physical examination that focuses on the respiratory system
- » Digital or film chest X-ray, interpreted by a NIOSH-certified B Reader
- » Spirometry test (lung function)
- » Test for latent tuberculosis (TB) (only for initial exam)
- » Any other tests deemed appropriate and necessary as related to respirable silica exposure by the physician or other licensed healthcare professional (PLHCP)

This examination may be combined with other medical evaluations and must be provided at least every three years. Tracking workers who wear respirators for crystalline silica exposure is critical.

Workers who are assigned to wear respirators, including filter facepieces, must follow Alberici's respiratory protection plan, including having no facial hair that interferes with the seal, having no condition that interferes with the seal or valve function, and wearing glasses, goggles, or other required PPE in a manner that does not interfere with the seal of the facepiece.

Employers must provide the following to the PLHCP:

- » A description of the employee's past, current, and future duties as they relate to respirable crystalline silica exposure
- » The employee's past, current, and future levels of exposure to respirable crystalline silica (if the employer does not have information on the employee's past or current exposure level because



they are following Table 1 and are not required to measure exposures, the employer can indicate if the employee is likely exposed at or above the PEL based on required respirator use under Table 1)

- » A description of any PPE used, or to be used, by the employee, including when and for how long the employee has used or will use that equipment
- » Information from records of employment-related medical examinations previously provided to the employee and currently within the control of the employer

Projects and estimators should plan accordingly during bids to include the cost of medical evaluations and respirators/respiratory fit testing. Additionally, projects should work with the risk management department and the program administrators to identify occupational clinics that can provide these examinations and possibly negotiate reduced costs based on volume.

Within 30 days of the examination, employees must receive a full medical report. This report becomes the property of the employee, and the company does not have the right to this information unless the employee authorizes it. The employer can obtain the following without consent from employee:

- » The date of the examination
- » A statement that the examination has met the requirements of this section
- » Any recommended limitations on the employee's use of respirators

Information obtain by Alberici will be maintained with the employee's files for the duration of their employment plus 30 years, with the exception of employees who have worked for less than one year and have been provided their medical records upon termination of employment. An employee may give written authorization to include recommended limitations on their exposure to respirable crystalline silica and any statement regarding recommendations for evaluations by a pulmonary specialist.

## Training

Training for employees must include:

- » Health hazards associated with respirable crystalline silica exposure. For respirable crystalline silica, the health hazards include cancer, lung effects, immune system effects, and kidney effects.
- » The Hazard Communication (HazCom) Standard (HCS) applicable to crystalline silica
- » Specific workplace tasks that could expose employees to respirable crystalline silica
- » Specific measures the employer is implementing to protect employees from respirable crystalline silica exposure, including engineering controls, work practices, and respirators to be used
- » Fit testing, care, and use of respirators, including filter respirators. Employees must understand procedures and schedules for cleaning, disinfecting, storing, inspecting, repairing, discarding, and otherwise maintaining respirators. (Reminder that filter respirators must also be fit-tested/seal checked daily.)

Additional familiarization education is covered within the orientation to all newly hired employees. Information is available at their request.

## Project Responsibilities

It is essential that this program be incorporated not only at the corporate level but also at the project level. Many components to the program are specific to a project.



Projects must work with the Safety Department and warehouse to identify specific tools that are being used. The controls identified in Table 1 must be fully and properly implemented. This means controls are in place, tools are properly operated and maintained, and employees understand how to use them.

Alberici's Built In Safety process of planning, communicating, observing, and improving are applicable, and high-risk activities, including "new to the task" and "new to the tool" are also part of the process. Training is essential.

Several factors required for full and proper implementation of controls are listed in the discussion for each Table 1 entry. It is strongly recommended that projects use the small business guide to compliance for construction available by download at [www.osha.gov](http://www.osha.gov) (document 3902).

Indirect workers who may not be performing a task may still have respirable crystalline silica exposure. It is recommended that tasks performed under Table 1 or alternate control measures be isolated from other work. Where this is not possible, workers who are not directly engaged in the task and protected by the controls in place must have protection by barriers or the company's respiratory protection plan.

### **Subcontractors Management**

All subcontractors are expected to follow their company's Silica Exposure Control Plan.

### **Evaluation**

This program will be reviewed and evaluated on an annual basis or more frequently when warranted.

### **Additional Information**

All projects are requested to contact the Safety Department or the program administrators for further support and information.



## STAIRWAYS AND LADDERS

Stairways and ladders can be a major source of injuries in the construction industry if proper safety measures are not implemented. The project will designate a competent person at each project site responsible for stairway and ladder safety and coordinating with subcontractors on this issue.

The competent person is identified as one who can identify existing and predictable hazards in the surroundings or working conditions that are unsanitary, hazardous, or dangerous to employees, and who has authorization to take prompt corrective measures to eliminate them.

### Safety Training

Alberici will provide a training program for each worker using ladders and stairways as described in OSHA Standard §1926.1060. The program should enable each worker to recognize hazards related to ladders and stairways and to use proper procedures to minimize these hazards. The training will include:

- » The nature of fall hazards in the work area
- » The correct procedures for erecting, maintaining, and disassembling the fall protection systems to be used
- » The proper construction, use, placement, and care in handling of all stairways and ladders
- » The maximum intended load-carrying capacities of ladders used
- » In addition, retraining should be provided for each worker, as necessary.

### General Safety Measures for Stairways

- » Stairways that will not be a permanent part of the structure must have landings at least 30 inches deep and 22 inches wide at every 12 feet or less of vertical rise.
- » Stairways should be installed at 30 degrees and no more than 50 degrees from horizontal.
- » Variations in riser height or stair tread depth should not exceed 1/4 inch in any stairway.
- » Where doors or gates open directly onto a stairway, a platform should be provided that extends at least 20 inches beyond the swing of the door.
- » Metal pan landings and metal pan treads should be secured in place before filling.
- » Stairs should not be used until the metal pans have been poured.
- » All stairway parts should be free of dangerous projections, such as protruding nails, burrs, and splinters.
- » Slippery conditions on stairways should be corrected before the stairs are used.
- » Workers may not use spiral stairways that will not be a permanent part of the structure.

### General Safety Measures for Stair Rails and Handrails

- » Stairways having four or more risers or rising more than 30 inches should have at least one handrail. A stair rail should also be installed along each unprotected side or edge.
- » When the top edge of a stair rail system also serves as a handrail, the height of the top edge should not be more than 37 inches, or less than 36 inches, from the upper surface of the stair rail to the surface of the tread.
- » Winding or spiral stairways should be equipped with a handrail to prevent using areas where the tread width is less than 6 inches.



- » Stair rails should not be less than 36 inches in height.
- » Midrails or equivalent intermediate, structural members should be provided between the top rail and stairway steps.
- » Midrails should be located midway between the top of the stair rail and the stairway steps.
- » Screens or mesh, when used, should extend from the top rail to the stairway step and along the opening between top rail supports.
- » Intermediate vertical members should not be more than 19 inches apart.
- » Other intermediate structural members should be installed so that openings are no more than 19 inches wide.
- » Handrails and top rails should be capable of withstanding at least 200 pounds of weight applied within two inches of the top edge in any downward or outward direction.
- » The height of handrails should not be more than 37 inches or less than 30 inches from the upper surface of the handrail to the surface of the tread.
- » The height of the top edge of a stair rail system should not be more than 37 inches or less than 36 inches from the upper surface of the stair rail system to the surface of the tread.
- » Stair rail systems and handrails should be surfaced to prevent injuries.
- » Handrails should provide an adequate handhold.
- » The ends of stair rail systems and handrails should be constructed to prevent dangerous projections, such as rails protruding beyond the end posts of the system.
- » Temporary handrails should have a minimum clearance of 3 inches between the handrail and walls and other objects.
- » Unprotected sides and edges of stairway landings should be protected with standard 42- inch guardrails.
- » When stairs are installed and before concrete is placed on the steps, the offset in the stair tread should be filled in with lumber to eliminate the offset at the nosing.
- » Building stairways will be permanently installed before their use by construction personnel is permitted.

### **General Safety Measures for Ladders**

- » A double-cleated ladder or two or more ladders should be provided for 25 or more workers or when a ladder serves simultaneous two-way traffic.
- » Ladder rungs, cleats, and steps should be parallel, level, and uniformly spaced when the ladder is in position for use.
- » Rungs, cleats, and steps of portable and fixed ladders (except as provided below) should not be spaced less than 10 inches apart or more than 14 inches apart.
- » Rungs, cleats, and steps of step stools should not be less than 8 inches apart, or more than 12 inches measured from center.
- » Rungs, cleats, and steps at the base section of extension ladders should not be less than 8 inches or more than 18 inches apart measured from center. The rung spacing on the extension section should not be less than 6 inches or more than 12 inches.
- » Ladders should not be tied or fastened together to create longer sections unless they are designed for such use.
- » A metal spreader or locking device must be on each stepladder to hold the front and back



sections in an open position.

- » When splicing side rails, the resulting side rail should be equivalent in strength to a one-piece side rail made of the same material.
- » Two or more separate ladders used to reach an elevated work area should be offset with a platform or landing between the ladders, except when portable ladders are used to gain access to fixed ladders.
- » Ladder components should be surfaced to prevent injury.
- » Wood ladders should not be coated with any opaque covering.
- » Identification or warning labels must be visible and not damaged, defaced, or covered.
- » Ladders may not be used to gain additional heights in mobile elevating work platforms (MEWPs).
- » When portable extension ladders are used, the side rails should extend at least 3 feet above the upper landing surface. The ladder should be secured at the top and bottom.
- » Non-self-supporting ladders should be pitched 1 foot out from the support structure for every 4 feet of ladder height.
- » Ladders should be maintained free of oil, grease, and other slipping hazards.
- » Ladders should not be loaded beyond the maximum intended load.
- » Ladders should be used only for the purpose for which they are designed.
- » Fixed ladders should be attached at 90 degrees perpendicular to the floor or surface.
- » Ladders should not be used on slippery surfaces unless secured or provided with slip-resistant feet.
- » Ladders that can be displaced by project site activities or traffic should be secured to prevent accidental movement, or a barricade should be used to keep traffic or activities away from the ladder.
- » The area around the top and bottom of the ladders should be kept clear. A good rule is 3 feet around the ladder.
- » Ladders should not be moved, shifted, or extended while in use.
- » Ladders should have nonconductive side rails when they are exposed to energized electrical sources.
- » Stepladders should be set up so that the braces are locked and the ladder in its proper A-frame configuration.
- » The top (cap) and first step of a stepladder should not be used as steps.
- » Cross bracing on the rear section of stepladders should not be used for climbing.
- » Platform stepladders may be used to work from heights greater than 6 feet without fall protection if the platform is completely enclosed by a guardrail system.
- » Ladders should be inspected by a competent person for visible defects on a periodic basis and after any incident that could affect safe use.
- » Single-rail ladders should not be used.
- » When ascending or descending a ladder, the worker should face the ladder.
- » When working from a ladder, the body position should be within the perimeter of the rails of the ladder and facing forward into the ladder.
- » Each worker should use at least one hand to grasp the ladder when moving up or down the ladder (three-point contact).



- » Ladders should not be placed in front of doors that open toward the ladder unless the door is safely locked or otherwise guarded.

### *Ladder Inspections*

- » Ladders will be inspected at least monthly by a competent person for visible defects and after any incident that could have affected the safe use of the ladder.
- » Records of the monthly inspections shall be documented and kept at the project location.
- » Users must inspect the ladder prior to each use. If it is damaged, the user must tag and remove the ladder from service until it can be taken off site and/or destroyed.

### *Ladder Construction*

Only ladders meeting the following requirements are permitted on our project sites:

- » Portable wood ladders: ANSI Standard A14.1—latest edition
- » Manufactured fixed ladders: ANSI Standard A14.3—latest edition
- » Job-made ladders: ANSI 14.4 Standard—latest edition
- » Plastic/fiberglass ladders: ANSI Standard A14.5—latest edition
- » Aluminum or metal ladders are never allowed on Alberici projects

### *Wood Ladders*

Inspect wood ladders periodically for damage and deterioration. Close visual inspection is suggested. Do not “load test” the ladder by jumping on it because doing so can weaken or damage it.

Periodically treat wood ladders with a clear preservative such as varnish or shellac. Do not paint ladders as paint covers structural defects. Carefully check all metal fittings on wood ladders.

### *Job-Built Ladders*

- » Job-built ladders may be used when circumstances prohibit the use of standard step or extension ladders such as access in and out of trenches and excavations, to platforms, etc.
- » All wood parts should be seasoned, smoothly machined, and dressed on all sides.
- » Fasteners should be driven their full length and countersunk not more than 1/8 of an inch. Do not use double headed nails to build job-built ladders
- » Lumber for side rails should be of the appropriate strength, species, group, and grade.
- » Cleat board material should be free of as many knots as possible.
- » Fasteners for constructing job-built ladders can include nails, staples, or screws. The fastener should be of the appropriate strength for the load.
- » Job-built ladders should be tailored for their intended use.
- » Ladder width of single-cleat ladders should be between 16 and 20 inches. The width of double-cleat ladders should be between 18 and 22 inches.
- » Cleats should be continuous and extend the full width of double-cleat ladders.
- » Cleats should be level and parallel when positioned for use. The cleats should be spaced evenly between 8 inches and 12 inches from the tops of the cleats.
- » For more specific information on constructing job-built ladders, refer to the American National Standards Institute’s (ANSI) A14.4, Safety Requirements for Job-Made Ladders Standard.



## Diagrams of Job-Built Ladders (ANSI A14.4)

### Single-Rung Job-Built Ladder

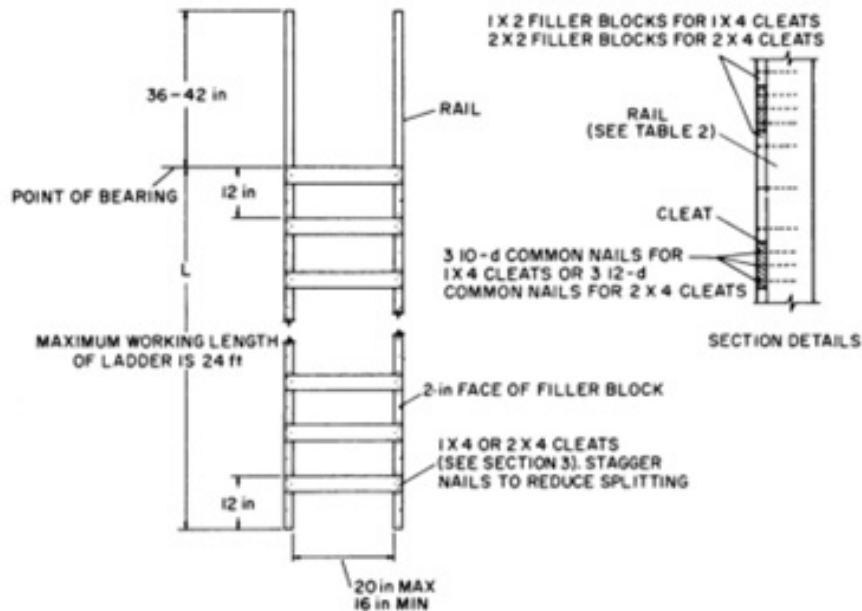

### Double-Rung Job-Built Ladder

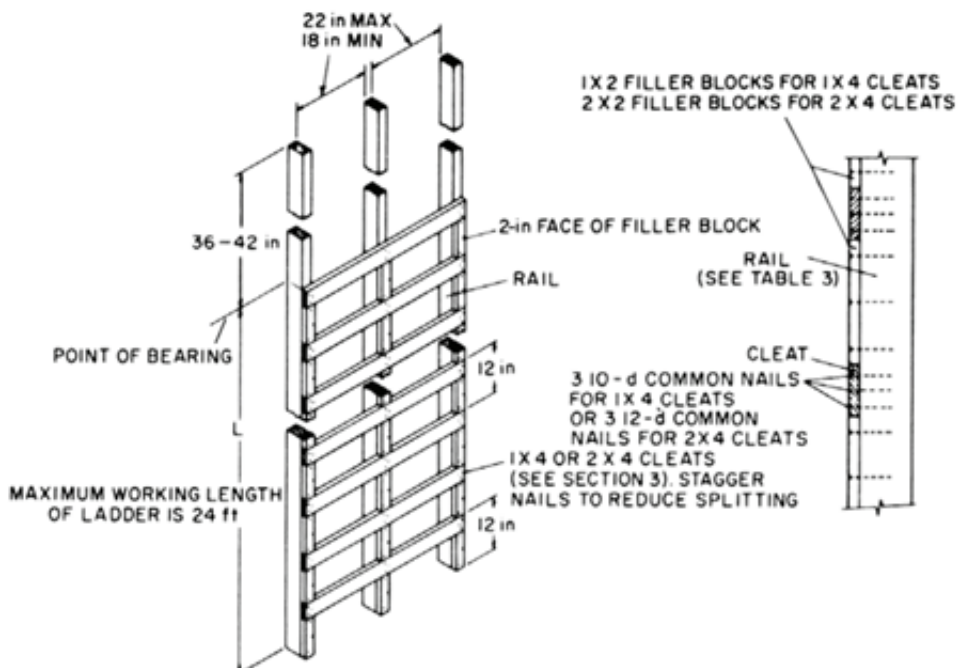

### All Ladder Types

- » Carefully inspect ladders of all types if a ladder is accidentally dropped or otherwise subjected to possible damage. Fiberglass ladders subjected to being dropped can have shattered siderails.
- » Destroy defective ladders.
- » When not in use, store all types of ladders under suitable cover to protect them from the weather.



Support ladders stored horizontally at both ends and at intermediate points to prevent the middle section from sagging. Sagging can loosen the rungs and warp the rails.

- » Do not lean ladders against columns if there is a possibility they could be struck and create a falling object hazard.

### **Ladder Safety Rules**

- » Inspect all ladders before using. Do not use the ladder if, upon inspection, you find broken rungs, siderails, or other defects. Take it out of service.
- » A documented ladder inspection should be conducted by a competent person at least monthly.
- » Set the ladder evenly and firmly before you climb it. Manufactured straight ladders must have safety feet if used on a hard, smooth floor.
- » The bottom of a straight ladder should be set at a distance of about one-quarter of the ladder's length away from the wall on which it is leaning.
- » A straight ladder or extension ladder should extend at least three feet above the access landing or a grab rail provided. The ladder must then be secured to a solid structure at the top and bottom.
- » If it is necessary to place a ladder in or over a doorway, barricade the door and post warning signs.
- » Only one person can be on a ladder at a time. Keep both hands free to climb the ladder.
- » Do not try to carry tools and materials while climbing up or down a ladder. Use a tool pouch or rope hand line.
- » Never overextend your body on a ladder – keep your belt buckle inside the siderails. Climb down and move the ladder when necessary.
- » When using a stepladder, make certain it is always open and level on all four feet. Lock the spreaders in place. Do not use it like a straight ladder.
- » Do not stand on the top or platform of a stepladder. If this is the only way to reach your work area, you must choose another method for completing your work.
- » When working in screen guard, ladders should be placed on plywood.
- » If extension ladders are needed, the sections must overlap a minimum of three rungs. After the top section has been raised to the proper height, make sure that safety latches are engaged and an extension rope is secured to a rung on the base section of the ladder.
- » Store ladders so that they do not fall over if struck or bumped. When storing ladders horizontally, store them to avoid sag.



## STEEL ERECTION

All activities in the construction, alteration, and/or repair of single- and multi-story buildings, bridges, and other structures involving steel erection will follow the requirements set forth in CFR 1926 Subpart R Steel Erection. Additional requirements contained in this manual will also apply.

### Site-Specific Erection Plan

Before steel erection can begin, a site-specific steel erection plan shall be developed by the project manager, project superintendent, and site safety coordinator/Alberici Safety Department. This plan should include:

- » Sequence of erection activity, developed in coordination with the controlling contractor, that includes the following:
  - Material deliveries
  - Material staging and storage
  - Coordination with other trades and construction activities
- » Description of the crane and derrick selection and placement procedures, including the following:
  - Site preparation
  - Path for overhead loads
  - Critical lifts, including rigging supplies and equipment
- » Description of steel erection activities and procedures, including the following:
  - Stability considerations requiring temporary bracing and guying
  - Erection bridging terminus point
  - Anchor rod (anchor bolt) notifications regarding repair, replacement, and modifications
  - Columns and beams (including joists and purlins)
  - Connections
  - Decking
  - Ornamental and miscellaneous iron
- » Description of the fall protection procedures that will be used to comply with the Fall Management section of this manual and OSHA §1926.502 (k).
- » Description of the procedures that will be used to comply with §1926.759 (Falling Object Protection)
- » Description of the special procedures required for hazardous non-routine tasks
- » Certification for each employee who has received training for performing steel erection operations as required by §1926.761 (Steel Erection Training Requirements) This must remain at the project location.
- » List of qualified and competent persons
- » Description of the procedures that will be utilized in the event of rescue or emergency response

### Approval to Begin Steel Erection

Before authorizing the commencement of steel erection, the controlling contractor shall ensure that the steel erector is provided with the following written notifications:

- » The concrete in the footings, piers, and walls and the mortar in the masonry piers and walls have



attained on the basis of an appropriate ASTM standard test method of field-cured samples either 75% of the intended minimum compressive design strength or sufficient strength to support the loads imposed during steel erection.

- » Any repairs, replacements, and modifications to the anchor bolts were conducted in accordance with §1926.755(b).

### Site Layout

The controlling contractor shall ensure that adequate roads into and through the site are available for safe equipment movement and delivery of steel. The controlling contractor is also responsible for a firm, properly graded, and drained area that is readily accessible to the work with adequate space for the safe storage of materials and the safe operation of the erector's equipment.

### Cranes and Rigging

All crane and rigging requirements should be adhered to as applicable. Alberici prohibits the practice of multiple lifts (Christmas treeing) on a project until a plan is provided and demonstrated that the work can be performed safely. The AHA must detail the steps used, and each person involved in multiple lifts must sign the AHA acknowledging their understanding.

Operators involved in steel erection must be qualified using the procedure identified in the cranes and rigging section of this manual.

### Fall Protection Regulations

§1926.760(a) Subpart R recognizes exceptions for different activities requiring fall protection. Alberici requires the use of 100% fall protection with any fall potential of 6 feet or greater with no exceptions.

§1926.760(c) controlled decking zone (CDZ): Alberici requires 100% fall protection on the project for any decking work. Zones may be established to control unauthorized entry to the area, but decking crews shall follow the fall protection requirements.

§ 1926.760(d): The support posts for guardrail systems include wire rope guardrails. Alberici requirements for use of wire rope guardrails:

- » ½-inch diameter wire rope or larger shall be used for top rails. All wire rope clips shall be installed and maintained per the manufacturer's requirements. This will require three clips (minimum) at each turn or connection.
- » The top rail shall be 42± 3 inches above the platform. No more than 3 inches of deflection is allowed in the top and midrails. Consideration must be made for finished floor heights.
- » Uprights shall be spaced no more than 8 feet apart.
- » A toe board shall be in place. The toe board shall not be more than ¼ inch above the floor and be a minimum of 3½ inches in vertical height from their top edge to the level of the walking/working surface.
- » Midrails shall be installed at a height midway between the top edge of the guardrail system and the walking/working level.
- » The top guardrail shall be flagged every 6 feet or less with highly visible material (typically red barricade tape). Additionally, guy wires must be flagged to increase their visibility.
- » The top guardrail shall support without failure a force of 200 pounds in either a downward or outward direction. The midrails shall support without failure a force of 150 pounds in either a downward or outward direction.



## Steel Erection Policies

- » Taglines will be used on all loads and must be of an appropriate length to provide an appropriate level of control.
- » Employees involved in unloading trucks shall not put themselves at risk of falls greater than 6 feet. A site-specific steel erection plan and site-specific AHA should address alternatives to employees climbing onto trucks loaded with steel. Ladders must be used to gain access to the trailer platform.
- » A platform ladder is the preferred option for accessing truck beds. Truck beds should never be climbed on or jumped from.
- » Employees connecting steel shall bolt up each end with a minimum of two bolts wrench-tight before releasing the rigging. At no time will employees be allowed on a live load.
- » When setting columns, before unhooking the column from the lifting device, the nuts on the anchor bolts shall be drawn tight or temporary guy wires shall be installed securely.
- » Areas below structural steel erection shall be barricaded and signs indicating overhead work shall be posted. No other work is allowed below steel erection on the project. There are no exceptions. Other work must be coordinated so that the steel erection is not interfered with.
- » All employees must be protected from falling objects.
- » Containers for bolts and drift pins shall be provided and secured when in use to prevent accidental displacement.
- » No loose materials will be allowed on the steel.
- » Two employees shall be assigned to operate each drilling and reaming operation.
- » Magnetic drills shall be secured to the structure to prevent dropping in the case of power failure. It is required that electrical receptacles being used during mag drilling be tagged with a danger tag stating that the circuit is used for a magnetic drill. Cord connections must be taped to prevent discontinuity of power during magnetic drilling operations.
- » A competent person for the steel erection company must provide an evaluation of the need for guying and bracing when plumbing of columns.
- » All decking must be tight-fitting, and gaps, especially at columns, must be fitted with material that will prevent an employee from falling through and will keep material from falling to a lower level.
- » Any open holes must be covered with adequate fall protection before pulling out of the area.

AHA Template for Steel Erection located on the Commons should be reviewed for additional information. Detailed AHAs for each component of steel erection are available on the Commons.



## STRETCH AND FLEX PROGRAM

This Stretch and Flex program was designed with the guidance of a license healthcare professional. It has been used continuously by Alberici since 2002.

Construction workers have very strenuous jobs. Their work often requires quick responses, fast reflexes, sheer physical strength, excellent balance, and adaptability in what can be a changeable situation. Because of the nature of the work, employees need to be in the best physical, mental, and psychological shape possible.

Injuries can happen for a number of reasons but most often happen when one or more of these vital functions are lacking. The following information and exercises may greatly assist the employee to be in the best physical and mental shape possible.

The Stretch and Flex program has a variety of whole-body activities, focusing on traditional muscle group stretching and balance activities. The stretches are not calisthenics, are not strenuous, and are designed to warm up muscle groups and help prevent injuries. If any of the stretches cause pain, the employee may want to consult their personal physician.

This program has been shown to reduce preventable strains and strains as a result of work activities. Worker's compensation injuries for back strains were reduced by 50% the first year of the program, and employees who routinely stretch find that they are more flexible in performing their work activities.

The program is available as part of the Built In Safety program presentation as a Microsoft PowerPoint file in the safety orientation on the Commons.

### Stretching Outline

#### *Introduction to Pre-Work Stretching*

- » Keeps muscles supple
- » Prepares for improvement
- » Helps make a daily transition from inactivity to vigorous activity without undue strain
- » Stretching when done correctly is not stressful or painful
- » Everybody can stretch

#### *Why Stretch?*

- » Reduces muscle tension
- » Helps coordination
- » Increases range of motion
- » Prevents injuries
- » Makes strenuous activities much easier
- » Develops body awareness
- » Promotes circulation
- » Promotes feeling of wellbeing



### *How to Stretch*

- » Relax sustained stretch
- » Never bounce or overstretch
- » The easy stretch
- » The developmental stretch

### *When to Stretch*

- » Before starting the day
- » During the day
- » After prolonged sitting or standing or activity
- » When you feel stiff
- » When there is time and when it is convenient
- » Strive for consistency

### *Breathing*

- » Slow, rhythmical, and under control
- » Exhale as you develop the stretch
- » Breathe slowly during the hold time
- » Never hold your breath

### *Counting*

- » Count if you need to

### *Conclusion*

- » Keep it enjoyable and pain-free
- » Always listen to your body. If these stretches create unusual discomfort, you may want to consult your personal physician.



## WELDING AND BURNING

### Hazards

The hazards generally associated with welding are hot sparks, arc radiation, air contamination, electrical shock, chipping slag, contact with hot metals, and handling compressed gases. The amount and type of fumes and gases involved will depend on the welding process, the base material, the filler material, and the shielding gas, if any. The toxicity of these contaminants (fumes and gases) depends primarily on their concentrations and how they affect the human body.

#### *Primary Gases in Welding*

- » **Ozone:** Ozone is formed by electrical arcs and the discharge of light into the air. Welders who endure significant exposure to this gas have been known to develop pulmonary edema. Ozone can be a problem when gas-shielded, metal-arc welding is conducted in an enclosed area with poor ventilation.
- » **Oxides of Nitrogen:** Oxides of nitrogen are very irritating to the eyes and mucous membranes. Exposure to high concentrations may immediately produce coughing and chest pain. Pulmonary edema can occur and cause death within 24 hours.
- » **Carbon Monoxide:** In some welding processes, carbon dioxide is converted into carbon monoxide. In the case of carbon dioxide-shielded, metal-arc welding, carbon monoxide concentrations can reach high levels in fumes near the arc. With adequate ventilation, the carbon monoxide concentration in the welder's breathing zone can be maintained at harmless levels.
- » **Carbon Dioxide:** Carbon dioxide is not usually considered a toxic gas. It is found naturally in the atmosphere and in the air present in our lungs.
- » **Oxygen:** Pure oxygen will not burn or explode. It supports combustion; that is, it causes other substances to burn when they are raised to high temperatures. Combustible materials burn much more rapidly in oxygen than in air. Oxygen forms explosive mixtures in certain proportions with acetylene, hydrogen, and other combustible gases.
- » **Acetylene:** Acetylene, like other combustible gases, ignites readily and, in certain proportions, forms a flammable mixture with air or oxygen.
- » **Other Gases:** Other gases can be used in welding and can be combustible. These include propane, propylene, and their mixtures. They are usually stored in liquid form in cylinders.

### Toxic Inhalants and Irritants

The following metals can be found in welding fumes, depending on what type of metal you are welding: cadmium, chromium, lead, magnesium, manganese, mercury, molybdenum, nickel, titanium, vanadium, zinc, and the fluorides. Depending on the type of metal fumes inhaled, the following effects could occur to the human body: pulmonary edema, system poisoning, metal fume fever, and other pulmonary disorders.

#### *Chlorinated Hydrocarbons*

Degreasing operations may involve chlorinated hydrocarbons; these liquids or vapors must be kept away from ultraviolet radiation generated from welding operations.

### Responsibilities for Welding Operations

#### *Management*

- » Establish approved areas for welding and cutting within a building.
- » Establish procedures for having management approve the work to be done (burn/weld permits).



- » Designate an individual responsible for authorizing all welding operations (with this person being aware of fire hazards involved).
- » Arrange for the use of approved apparatus, such as torches, manifolds, and hoses. Ensure that the torch sets have flashback arrestors.
- » Make sure that welders or torch users and their supervisors have been suitably trained in the safe operation of their equipment, the safe use of the process, and emergency procedures in the event of a fire.
- » Advise all welders about flammable materials or hazardous conditions of which they may not be aware.

### *Superintendents*

- » Be responsible for the safe handling of the welding and cutting equipment and for workers' safe work practices.
- » Ensure welding leads and/or hoses are in good condition.
- » Determine the combustible materials and hazards present or likely to be present in a work location.
- » Protect combustibles from ignition by moving the work to a location free from dangerous combustibles.
- » Have combustibles moved to a safe distance from the work or have combustibles properly shielded against ignition if the work cannot be moved.
- » Schedule welding and cutting so that operations that might expose combustibles to ignition are not started during such work.
- » Make sure that workers have received approval before welding (burn permits signed and authorized by facility).
- » Make sure that fire protection and extinguishing equipment is properly located near welding. Extinguishers must be readily available and within 25 feet of hot work activities.
- » Make sure that the welding area is inspected one-half hour after welding is completed to ensure that no sparks or smoldering fires are present.
- » Assign fire watch as necessary.

### *Employees*

- » Be familiar with §1926.354 and with §1926.352(a), (b), and (c). If gas-shielded arc welding is done, they must be familiar with the American Welding Society Standard
- » A6.1-1966
- » Handle equipment safely and use it so as not to endanger lives and property.
- » Have supervisor's approval before starting to weld or cut.
- » Only weld or cut where conditions are safe and only continue as long as conditions are unchanged from those under which approval was granted.
- » Advise management when equipment needs repair.
- » Use necessary personal protective equipment for the project, such as respirators, leathers, gloves, correct shaded lenses, and fire-resistant clothing.
- » Use fall arrest systems as required.



## Welding and Cutting in Confined Spaces

All the normal procedures for confined space apply to welding and torch-cutting in confined spaces. In addition, the following apply:

- » When sufficient ventilation cannot be obtained without blocking the means of access, employees in the confined space will be provided with airline respirators.
- » An employee outside the confined space will be assigned to maintain communication with those inside and to assist them in the event of an emergency.
- » Torches and hoses shall have the gas turned off at the bottle when not in use, such as during break and lunch. At the end of the shift, they shall be removed from the confined space.

### *Welding, Torch-Cutting, or Heating Toxic Metals*

Toxic metals released with heat include zinc, lead, mercury, cadmium, chromium, and beryllium. Galvanizing metals nearly always contain one or more of these toxic metals and require special attention.

- » Adequate mechanical ventilation will be provided to maintain exposures below the PEL.
- » Where exposure may approach or exceed a PEL, respirator protection will be selected and applied. Refer the Respiratory Protection procedures.
- » Other personnel exposed to the same atmosphere as the welders or burners shall be protected in the same manner as the burner or welder.
- » Contact the Safety Department for assistance if any toxic metals are present.

### *Metals with Preservative Coatings*

Before any welding or heating is done on metals that have a protective coating (including paint) whose flammability is not known, a test will be done by a competent person to determine the flammability (see OSHA Standard §1926.354 for details).

In enclosed spaces, all coatings will be stripped from the metal at least 4 inches from the areas where heat will be applied, or the employees will be required to use an airline respirator.

If the work is to be done in the open air, filter-type respirators may be acceptable, depending on the material.

The Safety Department should be contacted before heating metals with protective coatings.

### *Precautions*

- » Welding or cutting will not be permitted under the following conditions:
  - In areas unauthorized by management
  - In areas where there is no fire extinguisher in the immediate area
  - In the presence of explosive atmospheres, as when flammable gases, vapors, liquids, or dusts are detected in the air
  - In areas near storage of large quantities of combustibles, such as paper and wood pallets
- » Before welding or cutting is permitted, the following should be done:
  - The area should be inspected by the superintendent authorizing the welding or cutting.
  - Through the on-site permit system, the superintendent should inform the welder as to what precautions must be taken.



- The permit should be signed and posted near the welding area by the authorizing supervisor once the following is verified:
  - Welding and cutting equipment to be used is in satisfactory operating condition and in good repair.
  - When combustible materials—such as paper clippings, wood shavings, or fibers—are on the floor, the floor is swept clean for a radius of 35 feet. Combustible floors should be kept wet (except wood on concrete), covered with damp sand, or protected by fire-resistant shields. Where floors have been wet down, welders operating arc welding or cutting equipment should be protected from possible shock.
  - Where practicable, all combustibles are relocated at least 35 feet from the welding site. Where relocation is impracticable, combustibles should be protected with flame-resistant covers. The edges of covers should be tight to the floor to prevent sparks from going under them. This precaution is also important at overlaps where several covers are used to protect a large pile.
  - Openings or cracks in walls, floors, or ducts within 35 feet of the welding area are covered to prevent the passage of sparks to adjacent areas. Welding, cutting, or burning on upper levels may require a fire watch and/or protection from sparks on levels below if there is a possibility of sparks dropping through cracks or holes.
  - Conveyor systems that might carry sparks to distant combustibles are suitably protected.
  - Welding or cutting on pipes or other metal in contact with combustible walls, partitions, ceiling, or roofs is not started if the work is close enough to cause ignition through direct contact.
  - Fully charged and operable fire extinguishers appropriate for the type of possible fire are available at the work area.
  - Nearby personnel are suitably protected from heat and sparks. Personnel should not look at the welding arc. A weld screen will be provided when welding. Use more than one screen in areas where there are many people working or passing by.
- » Fire watches should be required by the authorizing individual if:
  - There is a potential for a fire.
  - The building's construction has an appreciable amount of combustible material within 35 feet of the welding area.
  - There is an appreciable quantity of combustibles more than 35 feet away that can easily be ignited by sparks.
  - There are wall or floor openings within 35 feet of welding that expose combustible materials in adjacent areas, including concealed spaces in floors and walls.
  - There are combustible materials adjacent to the opposite side of metal partitions, walls, ceilings, or roofs that are likely to be ignited by a heat build-up in that metal.
- » Fire watches should also include:
  - Having a fire extinguisher readily available and having the person conducting the fire watch trained in its use
  - Having the person conducting the fire watch be familiar with the procedures for fire notification
  - Watching for fires in all exposed areas and trying to extinguish them first only within the capacity of the fire extinguisher or by notifying the proper authorities
  - Providing a fire watch for at least a half-hour after completion of welding or cutting operations to detect and extinguish possible smoldering fires



## Training

A training program, as well as regular discussions at SafeTalks, should emphasize that welders or cutters can provide for their safety and the safety of all co-workers by observing the following safe practices:

- » Fire watchers must have training in the safe use of fire extinguishers. Use the acronym PASS for “pull, aim, squeeze, sweep.” Fire watchers must know which extinguisher is appropriate for the work performed. Alberici uses ABC fire extinguishers as their extinguisher of choice.
- » For work at more than 6 feet above floor or ground level, use a platform with railings or a personal fall arrest system and lanyard.
- » After welding or cutting is completed, mark hot metal or post a warning sign to keep workers away from heated surfaces.
- » Follow safe housekeeping principles. Don’t throw electrode or rod stubs on the floor; discard them in proper waste containers. Keep tools and other tripping hazards off the floor by putting them in a safe storage area.

## Gas Welding and Burning

### *Handling Cylinders*

- » Only accept cylinders approved for use in interstate commerce for transportation of compressed gases.
- » Do not remove or change numbers or marks stamped on cylinders, especially warnings such as “FLAMMABLE” and “OXIDIZER.”
- » Because of their shape, smooth surface, and weight, cylinders shall not be carried by hand. Cylinders may be rolled on their bottom edge but should never be dragged. Cylinders weighing more than 40 pounds should be transported on a hand or motorized truck and secured during transport. Do not attempt to lift a cylinder up on the shoulder to carry.
- » Protect cylinders from cuts or abrasions.
- » Do not drop cylinders or let them strike each other violently.
- » Do not use cylinders for rollers, supports, or any purpose other than to contain gas.
- » Do not tamper with safety devices in valves or on cylinders.
- » When in doubt about the proper handling of a compressed gas cylinder or its contents, consult the gas supplier.
- » When empty cylinders are to be returned to the vendor, mark them as “EMPTY” with chalk. Close the valves and, if the cylinder is designed to accept a cap, replace the valve protection caps.
- » Keep cylinders upright and secured when in storage. Keep upright when empty – do not invert LP gas or propane cylinders. LP gas or propane may be stored on horizontal racks.
- » Load cylinders to be transported to allow as little movement as possible. Secure them to prevent violent contact or upsetting. Identify the storage cages with the name of the compressed gas.
- » Always consider cylinders as being full and handle them with care. Keep empty cylinders stored in a separate area from full cylinders.
- » Keep fire extinguishers nearby when storing compressed gas cylinders.

### *Using Cylinders*

- » Use cylinders, particularly those containing liquefied gases and acetylene, in an upright position and secure them against accidentally being knocked over.



- » Unless the cylinder valve is protected by a recess in the head, keep the metal cap in place to protect the valve when the cylinder is not connected for use. A blow on an unprotected valve might cause gas under high pressure to escape.
- » Make sure the threads on a regulator or union correspond to those on the cylinder valve outlet. Do not force connections that do not fit.
- » Open cylinder valves slowly. A cylinder not provided with a hand-wheel valve should be opened with a spindle key, a special wrench, or another tool provided or approved by the gas supplier.
- » Do not use a cylinder of compressed gas without a pressure-reducing regulator attached to the cylinder valve.
- » Before connecting to a cylinder valve outlet, “crack” the valve for an instant to clear the opening of particles of dust or dirt. Always point the valve and opening away from the body and not toward anyone else. Never crack a fuel gas cylinder valve near other welding work or near sparks, open flames, or other possible sources of ignition.
- » Do not attempt to repair or alter cylinders, valves, or attachments. Repair and/or cylinder maintenance should only be attempted by the manufacturer.
- » Unless the cylinder valve has been closed tightly, do not attempt to stop a leak between the cylinder and the regulator by tightening the union nut.
- » Do not permit sparks, electric currents, excessive heat, or flames to come in contact with the cylinder or attachments.
- » Never use oil or grease as a lubricant on valves or attachments of oxygen cylinders. Keep oxygen cylinders and fittings away from oil and grease. Do not handle such cylinders or apparatus with oily hands, gloves, or clothing.
- » Never use oxygen as a substitute for compressed air in pneumatic tools. Use it only for the purpose for which it is intended.
- » Never bring cylinders into tanks or unventilated rooms, confined spaces, or other closed quarters.
- » Do not fill cylinders except with the consent of the owner and then only in accordance with the Department of Transportation (DOT) or other applicable regulations. Do not attempt to mix gases in a compressed gas cylinder or to use a cylinder for purposes other than those intended by the supplier.
- » Before a regulator is removed from a cylinder valve, close the cylinder valve and release the gas from the regulator.

### *Handling Leaks in Cylinders*

Fuel gas cylinders in which leaks occur should be taken out of use immediately and handled as follows:

- » Close the valve and take the cylinder outdoors, well away from any source of ignition. Properly tag the cylinder and notify the supplier. A regulator attached to the valve may be used temporarily to stop a leak through the valve seat.
- » If a leak occurs at a fuse plug or other safety device, take the cylinder outdoors, well away from any source of ignition. Open the cylinder valve slightly and permit the fuel gas to escape slowly. Tag the cylinder plainly. Post warning signs against approaching with lighted cigarettes or other sources of ignition. An authorized, properly trained person, such as a member of the fire watch, should stay in the area until the cylinder is depressurized to make sure that no fire occurs. Promptly notify the supplier and follow the instructions for returning the cylinder.



### *Hose and Hose Connections*

- » Do not use unnecessarily long hoses because it takes too long to purge. When a long hose must be used, make sure it does not become kinked or tangled and that it is protected from being run over by trucks or otherwise damaged. Where long hoses must be used in areas exposed to vehicular or pedestrian traffic, suspend it high enough overhead to permit unobstructed passage.
- » Repair leaks at once. Besides being a waste, escaping fuel gas or oxygen may ignite and start a serious fire; it may also set fire to the welder's clothing. Repair hose leaks by cutting the hose and inserting a splice. Don't try to repair a leaky hose by taping.
- » Examine hose periodically and frequently for leaks and warm places, and check hose connections. Test for leaks by immersing the hose under normal working pressure in water.
- » Protect hose from flying sparks, hot slag, other hot objects, and grease and oil. Store hose in a cool place.
- » A single hose having more than one gas passage is not recommended because a wall failure would permit the flow of one gas into the other gas passage. When parallel links of oxygen and acetylene hose are taped together for convenience and to prevent tangling, not more than 4 inches of every 12 inches of hose should be taped.
- » Flashback devices between the torch and hose and a check valve should be placed between the hose and regulator. If a flashback occurs and burns the hose, discard the burned section. Purge a new hose before connecting it to the torch and the regulator.

### *Torches*

- » Select the proper welding head or mixer, tip, or cutting nozzle (according to the charts supplied by the manufacturer) and screw it firmly into the torch.
- » Before changing torches, shut off the gas at the pressure-reducing regulators and do not crimp the hose.
- » Do not use matches to light torches. Use a friction lighter, stationary pilot flame, or other suitable source of ignition. When lighting, point the torch tip so no one will be burned when the gas ignites.
- » Never put down a torch until the gases have been completely shut off. Do not hang torches from a regulator or other equipment so that they may come in contact with the sides of the gas cylinders. If the flame has not been completely extinguished or if a leaking torch ignites, it may heat the cylinder or even burn a hole through it.
- » When extinguishing the flame, close the acetylene and oxygen valves in the order recommended by the torch manufacturer. If the oxygen valve is closed first, carbon soot will be deposited in the air; however, this deposit ensures that the acetylene valve is closed tight when the flame is extinguished. If the acetylene valve is turned off first, no soot is formed, but there is no assurance that the fuel gas valve is closed and is not leaking.
- » To discontinue welding or cutting for a few minutes, closing only the torch valves is permissible. If the welding or cutting is to be stopped for a longer period (during lunch or overnight), proceed as follows:
  - Close the valves on the torch and ensure it is extinguished
  - Close the oxygen and acetylene cylinder valves
  - Open the torch valves to relieve all gas pressure from the hose and regulators
  - Close the torch valves, remove hose, remove hose from the regulator, remove the regulator from the bottle, and install safety cap



- Store torch and regulator in a manner to prevent damage
- Do not store hose in an enclosed box or cabinet, which may allow gas vapors to collect that were not purged from the hose. These can become a fire hazard.
- » Never merely turn off the gas supply at the torch. Doing so leaves the hose pressurized. Always cut the supply from the cylinder, bleed the lines, and, with the lines open, back off the regulator. The lines should then be coiled carefully, avoiding kinks.
- » If no hot work is to be performed for more than two consecutive shifts, all torch carts must be broken down and cylinders stored.

## Arc Welding

- » Arc welding is a process for joining metals by heating with an electric arc or arcs with or without the application of pressure, and with or without the use of filler metal. Either AC or DC may be used for arc welding or cutting of any kind. Some precautions for prevention of electric shock during arc welding are:
  - » Never change electrodes with bare hands or wet gloves or when standing on wet floors or grounded surfaces. Do not attempt to weld in wet or damp conditions.
  - » Ground the frames of welding units, portable or stationary, in accordance with the latest edition of the National Electric Code, NFPA 70. With a small welding unit, a primary cable containing an extra conductor, one end of which is attached to the frame of the welding unit, may be used. By using a proper polarized plug, this ground connection can be carried back to the permanently grounded connection in the receptacle of the power supply.
  - » Arrange receptacles of power cables for portable welding units so that it is impossible to remove the plug without opening the power supply switch or use plugs and receptacles that have approved full-load circuit breakers.
  - » Only cable free from repair or splices for a minimum distance of 10 feet from the cable end to which the electrode holder is connected shall be used, except that cables with standard insulated connectors or with splices whose insulating quality is equal to that of the cable are permitted.
  - » If a cable (either work lead or electric lead) becomes warm, exposing bare conductors, cover the exposed portion with rubber, plastic, or friction tape. The insulation repair on work lead cables should be equivalent in insulating character to the original cable covering.
  - » Keep welding cables dry and free of grease and oil to prevent premature breakdown of the insulation.
  - » Suspend cables on substantial overhead supports if the cables must be run some distances from the welding unit. Protect cables that must be laid on the floor or ground so that they will not interfere with safe passage or become damaged or entangled.
  - » Take special care to keep welding cables away from power supply cables or high-tension wires.
  - » Never coil or loop welding cable around the body.
  - » Keep fire extinguishers within ready access during welding operations.
  - » Ensure proper ventilation during welding. Use cartridge respirator when conditions are warranted.

## Personal Protection and Ventilation

- » Only minimal health hazards generally exist in open-air welding or cutting in large, well-ventilated areas, where clean carbon steel is welded or cut with bare or coated carbon-steel electrodes and without inert gas shielding.



- » Oxides of nitrogen are always generated near the welding or cutting arc. An inert- gas shield, however, minimizes the introduction of air to the arc. Concentrations of these oxides are generally above their PELs or TLVs within a few inches of the arc but are diluted rapidly by air movements. Local exhaust or general ventilation should be used to keep the concentrations of oxides of nitrogen within safe limits.
- » Ultraviolet radiation from the welding or cutting arc may also decompose chlorinated hydrocarbons, such as trichloroethylene and perchloroethylene, to form highly toxic substances such as phosgene. Since this decomposition can occur even at a considerable distance from the arc, degreasing operations and other work using these chlorinated solvents should be located so that no solvent vapor will reach the welding or cutting area or be exposed to arc radiation.
- » In spaces of at least 50,000 cubic feet, where welding is an essential part of the work, local exhaust or positive ventilation may not be required for the protection of welders on uncoated ferrous metals, provided that:
  - Welding bays are not structurally blocked so as to obstruct cross ventilation
  - The work is not done inside tanks, boilers, or other closed iron or steel containers
  - Space allowance of 10,000 cubic feet is assured each welder
  - Ceiling heights are greater than 16 feet
  - Process involved is other than inert-gas-shielded arc welding.
- » When welding must be performed in a space screened on all sides, the screens should be so arranged that they do not seriously restrict ventilation. They can be mounted about 2 feet above the floor unless the work is performed at so low a level that they must be nearer the floor to protect nearby workers from welding flash.
- » Local exhaust removal may be by means of movable hoods placed as near as practicable to the work being welded and provided with a rate of air flow sufficient to maintain a velocity in the direction of the hood of 100 feet per minute (fpm) at the point of welding when the hood is at its most remote distance from the point of welding.
- » Local exhaust may also be by a fixed enclosure with a top and not fewer than two sides that surround the welding or cutting operations, and with a sufficient airflow to maintain a velocity away from the welder of not less than 100 fpm.
- » Mechanical ventilation should consist of either general mechanical ventilation systems or local exhaust systems.
- » General mechanical ventilation should be of sufficient capacity and so arranged as to produce the number of air changes necessary to maintain welding fumes and smoke within safe limits, as defined in OSHA Subpart D, Occupational Health and Environmental Controls, Sections 1926.55, “Gases, Vapors, Fumes, Dusts and Mists,” and 1926.57, “Ventilation.”
- » Goggles, helmets, and shields that give maximum eye protection for each welding and cutting process should be worn by operators, welders, and their helpers. These items should conform to OSHA Subpart E, Section 1926.102.

### Hot Work Permit Spreadsheet

This spreadsheet has been developed for documentation of all hot work permits issued on your project. It is available on the theCommons. Open and save a copy, then select the tab for the number of hot work permit and print it. You will now have a log of all permits issued and control over the numbering and tracking of them.

SECTION III

# Environmental Safety





## ENVIRONMENTAL AWARENESS

Alberici has developed and implemented policies, programs, and procedures designed to achieve compliance with federal, state, and local environmental laws and regulations. These programs and concomitant processes have been developed to be compliant with ISO 14001 Environmental Management Standards.

Many environmental rules and regulations have been promulgated and can affect Alberici's project work.

These regulations include:

- » The **Clean Air Act** (governing point and non-point air pollution sources) including asbestos and a new section soon to apply to off-road diesel engines
- » The **Federal Water Pollution Control Act** of 1972 and amendments of 1977 known as the Clean Water Act that requires land disturbance permits if disturbing more than one acre (**SWPPP**), and section 404 permits if disturbing wetlands, which requires spill prevention control and countermeasures planning for oil spills through the Oil Pollution Prevention Act
- » **Comprehensive Environmental Response, Compensation, and Liability Act (CERCLA)**, known as Superfund, with the primary purpose of developing a mechanism of response for the immediate cleanup of hazardous waste contamination from accidental spills or from abandoned hazardous waste sites or from actively managed sites or vessels not covered by the Resource Conservation and Recovery Act (RCRA)
- » **Superfund Amendments and Reauthorization Act (SARA)** of 1986, or Title III, which contains the **Emergency Planning and Community Right-to-Know Act (EPCRA)**, which requires establishment of local emergency planning committees (LEPC) and adopted Community Right-to-Know rules as well as requiring annual reporting of toxic air pollutants

Many of the rules affect how Alberici can do business and require an awareness of some of the requirements to avoid regulatory violations and potentially large fines.

- » Alberici does not perform investigative or remedial environmental work.
- » Alberici will never sign hazardous or special waste manifests, as this is the responsibility of the generator (or owner) of the waste.

In the role of construction manager and/or general contractor, Alberici recognizes the moral, ethical, and legal responsibilities to direct and ensure that Alberici and subcontractor site activities be performed using techniques and/or methods consistent with regulatory requirements, established procedures, and best management practices.

In most instances the responsibility for identifying and obtaining the required project- or site-specific permits is the responsibility of the owner, architect, and/or consulting engineer.

Alberici is responsible for the implementation of specific permit conditions and ensuring that the contractor and subcontractors comply with the relevant rules and regulations.



## Training

Alberici requires operations personnel who manage, oversee, or direct field activities or individual components of field activities to complete annual environmental awareness training.

Courses offered in Alberici ACE include, but are not limited to, lead awareness, asbestos awareness, biological pollutants (i.e., mold), and general environmental awareness.

Course curricula are subject-specific and include information on the potential hazards of the material (i.e., health effects), routes of exposure, selection and use of appropriate PPE, regulatory reporting and site communication requirements, and an overview of regulations governing the generation, transportation, and disposal of special and hazardous wastes.

The roles and responsibilities of the construction manager and/or general contractor on multi-employer worksites where hazardous materials or special contaminants are present are discussed.

Applicable notification and documentation requirements pertinent to sites with these types of issues are also discussed.



## SPILL CONTAINMENT PLAN

Alberici uses limited amounts of hazardous and/or chemical materials that could cause a spill of any magnitude.

However, any spill, no matter the size, is to be treated appropriately and all necessary actions taken to contain the spill and properly dispose of any waste.

Each job site must be surveyed for possible hazardous and/or chemical spills (i.e., threading oil, fuel). There should be a plan for containing and cleaning spills by the affected crews/trade partners.

In general, spills would be one gallon or less.

Prior to using any hazardous materials, the employee using the material will refer to the appropriate SDS for specific responses and actions for containment of spills.

For any job requiring hazardous material, Alberici will have appropriate resources for containment control.

The following procedures will be followed if a hazardous/chemical spill should occur:

1. Proper personal protective equipment (PPE) shall be worn during hazardous cleanup, i.e., rubber gloves and safety glasses. Planning of the activity and required PPE shall be done.
2. Contain the spill. Containment may occur with absorbent cloth rags (kept on the job site), absorbent “pigs,” kitty litter, or earth.
3. If the spill is in such an area large enough that it could reach entrances to sewers or drainage systems, begin containment by placing barriers at these entrances with absorbent materials (kept on the job site) in front of the barrier.
4. Apply absorbent material (kept on the job site) to the spill in quantities large enough to consume the entire spill.
5. Spill containment material shall be disposed of in accordance with federal, state, and local regulations. Communication is a critical step in the task of containment.

The facility’s environmental specialist and Alberici’s senior member on site at the time of the spill should be notified as soon as possible to identify specific clean up procedures.

After any spill incident, the project team will conduct an investigation as to how it occurred and how it could have been prevented.

All affected/involved workers will be required to have documented training in this procedure.

APPENDIX

# Forms

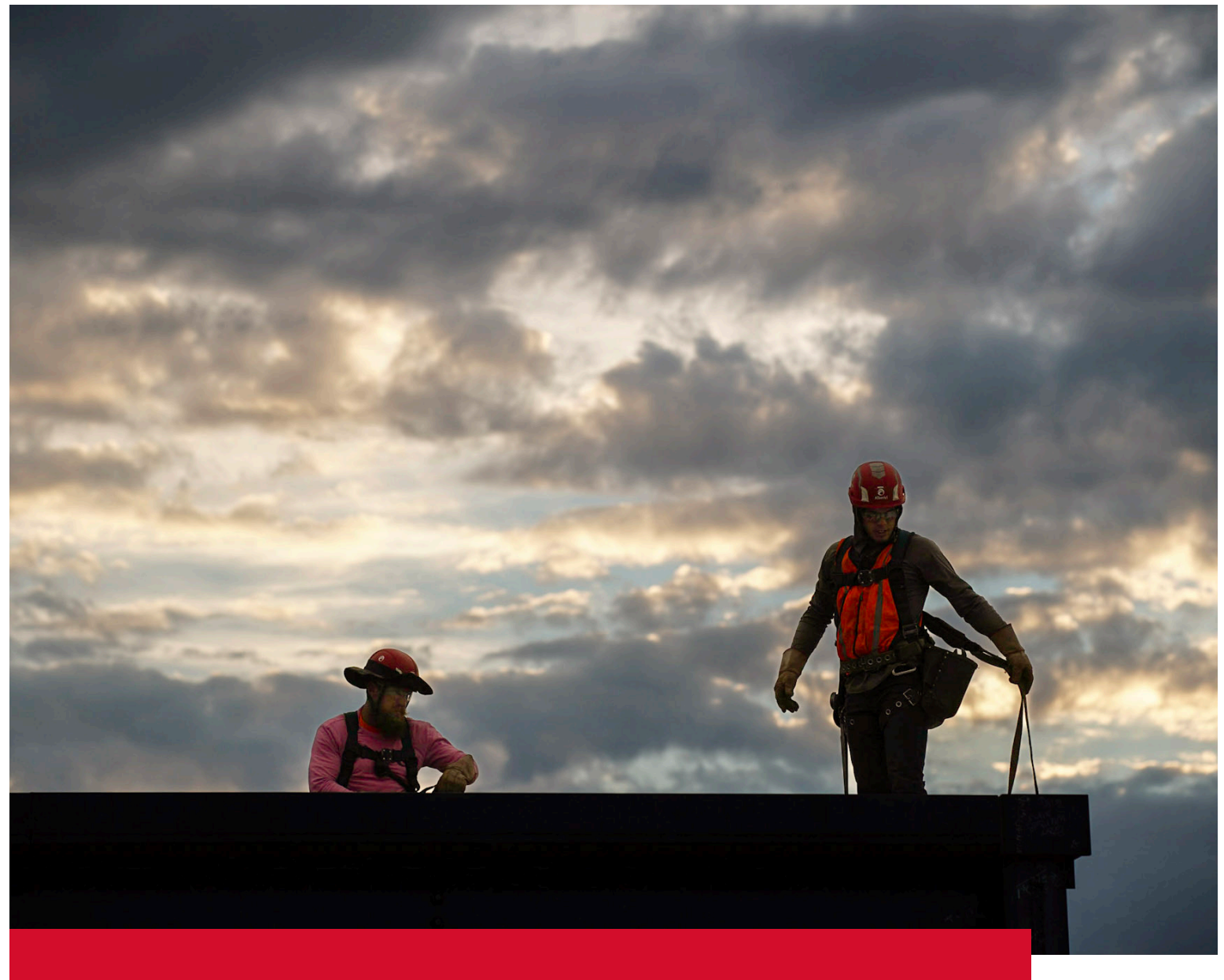



This appendix is not a complete library of safety forms. It contains some commonly used forms as well as some forms for high-risk activities. Additional safety forms are available on the Commons or through your safety professional.

# EMPLOYEE STATEMENT & NOTIFICATION OF INJURY

PLEASE TYPE OR PRINT CLEARLY  
SUBMIT TO INJURY.COM  
OR FAX TO (314) 733-2001/733-2011  
WITHIN 24 HOURS  
OF ACCIDENT/INJURY

Information Only  First Aid  Doctor Case

Date: \_\_\_\_\_

Time: \_\_\_\_\_ a.m.  p.m.

Project No.: \_\_\_\_\_

Project Name: \_\_\_\_\_

Name: \_\_\_\_\_

Job Title/Trade: \_\_\_\_\_

Address: \_\_\_\_\_

Date of Birth: \_\_\_\_\_

\_\_\_\_\_

Date of Hire: \_\_\_\_\_

Home Telephone: \_\_\_\_\_

Employee #: \_\_\_\_\_

Personal Email: \_\_\_\_\_

Is substance screening required? Yes  No

If yes, has one been performed? Yes  No

Brief Description of Injury: \_\_\_\_\_

Employee statement of injury (filled out by employee): \_\_\_\_\_

\_\_\_\_\_

\_\_\_\_\_

\_\_\_\_\_

\_\_\_\_\_

\_\_\_\_\_

\_\_\_\_\_

\_\_\_\_\_  
Employee Signature

\_\_\_\_\_  
Print Name

\_\_\_\_\_  
Project Manager Signature (Print Name)

\_\_\_\_\_  
Superintendent Signature (Print Name)

\_\_\_\_\_  
General Foreman Signature (Print Name)

\_\_\_\_\_  
Foreman Signature (Print Name)



## Near Miss/Property Damage Report

Please check:

Near Miss

Property Damage

Incident Date:		Time:	
Employee Name:		Trade:	
Employee #:		Project #:	
Project Name:			

Supervisor:	
Investigation By:	

### Description:

Attachments

Findings:  Unsafe Condition OR  At-Risk Behavior

### Root Cause of Accident/Incident:

### Action:

Signature:

\*\*\* Distribution: Safety Director, Project Manager, [injury@alberici.com](mailto:injury@alberici.com) & Site Safety File

## Lessons Learned and Root Cause Analysis

*Purpose: To obtain factual knowledge regarding injury/incident in order to implement corrective actions if necessary, in an effort to prevent recurrence.*

Information Only     First Aid     Doctor's Case

Name of Injured:		Employee #:	
Address:		DOB:	
City, State Zip:			
Home Phone:		Cell Phone:	
Title, Trade:		Skill:	JM: <input type="checkbox"/> or Apprentice: <input type="checkbox"/>

Project Name:		Project Number:	
Project Insurance:	OCIP: <input type="checkbox"/>	CCIP: <input type="checkbox"/>	WSIB: <input type="checkbox"/>
		Safety Reporting:	OSHA: <input type="checkbox"/> MSHA: <input type="checkbox"/> MOL: <input type="checkbox"/>

Injury Date:		Injury Time:	
Root Cause Date:		Date of Hire:	
Shift Start Time:		Shift Hours:	8 hrs <input type="checkbox"/> 10 hrs <input type="checkbox"/> 12hrs <input type="checkbox"/>
Weather Conditions:		Regular Work Being Performed?	Yes: <input type="checkbox"/> No: <input type="checkbox"/>

Describe Employee Injury: \_\_\_\_\_  
 \_\_\_\_\_  
 \_\_\_\_\_

Date and Time of Post Injury Substance Test: \_\_\_\_\_

Name all persons involved in incident: \_\_\_\_\_  
 \_\_\_\_\_  
 \_\_\_\_\_

What was employee doing when this incident, injury, accident occurred? \_\_\_\_\_  
 \_\_\_\_\_  
 \_\_\_\_\_  
 \_\_\_\_\_



## Lessons Learned and Root Cause Analysis

---

1. How is employee feeling today? \_\_\_\_\_
2. Was this task/activity identified in a PHD? Yes  No  N/A
3. Was the PHD reviewed and signed off by crew indicating understanding? Yes  No  N/A
4. List tools involved: \_\_\_\_\_

### Communicate:

1. Did this employee complete the site-specific new hire orientation? Yes  No  N/A
2. How long has this employee been on the project? \_\_\_ Years \_\_\_ Months \_\_\_ Days
3. How long has employee been in this trade? \_\_\_ Years \_\_\_ Months \_\_\_ Days
4. Is this task/activity typical to employee's trade? Yes  No  N/A
5. Was this employee considered At-Risk because he/she is (check all that apply):  
 New to the company                       New to the trade  
 New to the project                         New to the task
6. Should the SafeCard identify the employee as an At-Risk employee? Yes  No  N/A
7. Was this employee teamed with an At-Risk employee? Yes  No  N/A
8. How long has this employee had experience doing this task? \_\_\_ Years \_\_\_ Months \_\_\_ Days
9. Has project management conveyed to employees that they are empowered to stop work if they see something unsafe, feel unsafe or unclear about instructions? Yes  No  N/A
10. Does this employee understand he/she can stop work if they see unsafe activity, feel unsafe or unclear about instructions? Yes  No  N/A
11. Were the potential hazards along with safe work expectations of this task/activity identified in a SafeCard, SafeStart or SafeTalk meeting before the task began? Yes  No  N/A
12. Did the employee attend the Safe Start meeting and sign the Safe Card indicating understanding? Yes  No  N/A
13. Was this the first task of the day? Yes  No  N/A
14. If not, was a Safe Start held to identify potential hazards and safe work expectations?  
Yes  No  N/A  If no, explain \_\_\_\_\_
15. Did employee fully understand the potential hazards and safe work expectations regarding this task? Yes  No  N/A
16. Has this type of injury/accident occurred previously on this project? Yes  No  N/A
17. If yes, has this type of injury/accident occurred performing the same/similar task?  
Yes  No  N/A  If yes, explain \_\_\_\_\_
18. Has a stand down been conducted to review cause of injury/accident with crews?  
(If yes, attach copy) Yes  No  N/A
19. Will a Lessons Learned be developed and conveyed to crews regarding corrective actions?  
(If yes, attach copy) Yes  No  N/A



**Lessons Learned and Root Cause Analysis**

- 20. Has a Lessons Learned been developed previously regarding this type of injury/accident with regards to this task? Yes  No  N/A
- 21. Was this task/activity identified in an on-site behavior based observation? Yes  No  N/A
- 22. Were the observations recorded for this task/activity? Yes  No  N/A

**Observe:**

1. Did an At-Risk Behavior contribute to or cause this injury/accident? (Check all that apply)

	<u>Contribute</u>	<u>Cause</u>
Line of Fire	Yes <input type="checkbox"/> No <input type="checkbox"/> N/A <input type="checkbox"/>	Yes <input type="checkbox"/> No <input type="checkbox"/> N/A <input type="checkbox"/>
Eyes on Path	Yes <input type="checkbox"/> No <input type="checkbox"/> N/A <input type="checkbox"/>	Yes <input type="checkbox"/> No <input type="checkbox"/> N/A <input type="checkbox"/>
Overextending	Yes <input type="checkbox"/> No <input type="checkbox"/> N/A <input type="checkbox"/>	Yes <input type="checkbox"/> No <input type="checkbox"/> N/A <input type="checkbox"/>
Pinch Points	Yes <input type="checkbox"/> No <input type="checkbox"/> N/A <input type="checkbox"/>	Yes <input type="checkbox"/> No <input type="checkbox"/> N/A <input type="checkbox"/>
3 Point Contact	Yes <input type="checkbox"/> No <input type="checkbox"/> N/A <input type="checkbox"/>	Yes <input type="checkbox"/> No <input type="checkbox"/> N/A <input type="checkbox"/>

2. Does employee have knowledge of the at-risk behaviors through Safety Meetings, PHD or Orientations? Yes  No  N/A

3. Was a workplace/tool inspection performed before task began? Yes  No  N/A

If yes, who performed it?

\_\_\_\_\_   
 If no, explain \_\_\_\_\_

4. Did an unsafe condition contribute to or cause this injury/accident? Yes  No  N/A

If so, name the condition: \_\_\_\_\_

5. If applicable, was the employee trained/certified to use the equipment being operated? Yes  No  N/A

If no, explain \_\_\_\_\_

6. Was the correct equipment, tool, or rigging, used to perform this task? Yes  No  N/A

If no, explain \_\_\_\_\_

7. Was employee properly wearing the correct PPE for performing this task? Yes  No  N/A

8. Has employee had previous incidents, injuries with Alberici? Yes  No  N/A

9. Did a previous injury contribute to this injury/incident? Yes  No  N/A

10. Did employee recently work overtime before this incident/injury? Yes  No  N/A

If yes, # of OT hours per day \_\_\_\_\_ Total # of hours worked per week \_\_\_\_\_

# of consecutive weeks with OT \_\_\_\_\_

11. What is employee's daily travel time to and from project? \_\_\_\_\_



**Lessons Learned and Root Cause Analysis**

**Root Cause Investigation Summary**

From this investigation, identify the items/issues that contributed to this injury/accident.

- 1. \_\_\_\_\_
- 2. \_\_\_\_\_
- 3. \_\_\_\_\_
- 4. \_\_\_\_\_
- 5. \_\_\_\_\_

Were steps taken to eliminate/manage these items/issues identified in signed PHD? Yes  No  N/A

Were the PHD requirements for this task/activity followed? Yes  No  N/A

If no, explain \_\_\_\_\_

Did employee violate a communicated/written safe work requirement? Yes  No  N/A

Was this safety violation done knowingly? Yes  No  N/A

If yes, explain \_\_\_\_\_

**What is the Root Cause of this injury/accident?**

\_\_\_\_\_

\_\_\_\_\_

\_\_\_\_\_

Name the Lessons Learned: \_\_\_\_\_

\_\_\_\_\_

\_\_\_\_\_

What will be done differently to prevent accident/injury from reoccurring? \_\_\_\_\_

\_\_\_\_\_

Based on information obtained, should the PHD regarding this task be modified? Yes  No  N/A

**List participants in Root Cause Investigation: (Please print)**

Name: \_\_\_\_\_ Title: Project Manager

Name: \_\_\_\_\_ Title: Superintendent

Name: \_\_\_\_\_ Title: General Foreman



**Lessons Learned and Root Cause Analysis**

---

Name: \_\_\_\_\_ Title: Foreman

Name: \_\_\_\_\_ Title: Safety Professional

Name: \_\_\_\_\_ Title: \_\_\_\_\_

If PHD needs modification to identify the work, make revisions and complete training before allowing employee(s) to continue task. If PHD was not developed for this work and one was required, stop task, develop PHD, and train participants before task begins again.

PHD modified and submitted by: \_\_\_\_\_

**NOTE: Please submit re-enactment photos and applicable PHDs with this form.**

## CONFINED SPACE ENTRY PERMIT

CONTRACTOR REQUESTING PERMIT:	DATE OF ISSUE: VALID FOR TIME PERIOD:
LOCATION OF CONFINED SPACE:	# OF PERSONS ON JOB (entrants + attendant)
DESCRIPTION OF CONFINED SPACE (DIMENSIONS / ACCESS / EGRESS):	
DESCRIPTION OF WORK & PURPOSE OF WORK (HOT / COLD / INSPECTION / MATERIAL / EQUIPMENT TO BE USED):	
PERSON CONDUCTING PRE ENTRY ATMOSPHERIC TESTING: (record values in table below)	Print: _____ Sign: _____
EQUIPMENT USED TO CONDUCT ATMOSPHERIC TESTING:	Make: _____ Serial # _____
DATE OF LAST BUMP TEST / CALIBRATION:	Bump: _____ Calibration: _____

	PRE-ENTRY	TEST 1	TEST 2	TEST 3	TEST 4	TEST 5	TEST 6
TIME							
OXYGEN %							
LEL %							
H <sub>2</sub> S							
CO							
Other:							

ENTRY CHECKLIST:	Yes	No
1. Entrants and attendants trained?	<input type="checkbox"/>	<input type="checkbox"/>
2. Hazards analysis documented, communicated to crew and readily available for review?	<input type="checkbox"/>	<input type="checkbox"/>
3. Emergency procedures documented and communicated?	<input type="checkbox"/>	<input type="checkbox"/>
4. Emergency equipment readily available and in good repair?	<input type="checkbox"/>	<input type="checkbox"/>
<i>List emergency equipment:</i>		
5. Required PPE provided and communicated on hazard analysis?	<input type="checkbox"/>	<input type="checkbox"/>
6. Communications established between: Entrants → Attendant & Attendant → Emergency Rescue	<input type="checkbox"/>	<input type="checkbox"/>
7. Area adequately secured?	<input type="checkbox"/>	<input type="checkbox"/>

Entrants Name	Initial	Entrants Name	Initial
1.		4.	
2.		5.	
3.		6.	
Attendant Name	Initial	Attendant Name	Initial
1.		Alternate:	

**PERMIT RECEIVER (SUBCONTRACTOR):**

Print Name:	Sign Name:	Title:	Date:
-------------	------------	--------	-------

I HAVE REQUESTED THE PERMIT AND I UNDERSTAND THE NATURE AND EXTENT OF THE CONFINED SPACE WORK TO BE PERFORMED AND I WILL ENSURE THAT ALL NECESSARY PRECAUTIONS, INCLUDING THOSE LISTED ABOVE, ARE TAKEN FOR THE PROTECTION OF ALL WORKERS.

**PERMIT ISSUER**

Print Name:	Sign Name:	Title:	Date:
-------------	------------	--------	-------

I HAVE REVIEWED THE DETAILS AS LISTED ON THIS PERMIT (FOR THE REQUESTING CONTRACTOR) AND IT MEETS THE NECESSARY REQUIREMENTS.  
**NOTE: THIS PERMIT IS VALID FOR THE DATE OF ISSUE ONLY AND MUST BE DISPLAYED AT THE ACCESS TO THE CONFINED SPACE**





## Daily Checklist for Asbestos Projects

Project Name: \_\_\_\_\_ Project No. \_\_\_\_\_ Company: \_\_\_\_\_  
Superintendent: \_\_\_\_\_ Date: \_\_\_\_\_

	Yes	No
Did asbestos activities occur on this date?	<input type="checkbox"/>	<input type="checkbox"/>
<b>1. Regulated Area Established</b>	<b>Yes</b>	<b>No</b>
Barrier Tape Around Area	<input type="checkbox"/>	<input type="checkbox"/>
Warning Signs Posted at Entrances	<input type="checkbox"/>	<input type="checkbox"/>
<b>2. Worksite Barrier (Containment)</b>		
Area Heating/Ventilation System Off	<input type="checkbox"/>	<input type="checkbox"/>
Floor Covered (Where Applicable)	<input type="checkbox"/>	<input type="checkbox"/>
Wall Covered	<input type="checkbox"/>	<input type="checkbox"/>
All Edges Sealed	<input type="checkbox"/>	<input type="checkbox"/>
Penetrations Sealed	<input type="checkbox"/>	<input type="checkbox"/>
Entry Curtains Erect and Operable	<input type="checkbox"/>	<input type="checkbox"/>
<b>3. Differential Pressure Containment</b>		
Air Filtering Devices in Constant Operation	<input type="checkbox"/>	<input type="checkbox"/>
Differential Pressure Achieved	<input type="checkbox"/>	<input type="checkbox"/>
Recording Manometer in Operation	<input type="checkbox"/>	<input type="checkbox"/>
<b>4. Electrical</b>		
All Wiring Checked for Live Voltage	<input type="checkbox"/>	<input type="checkbox"/>
Workers Protected Against Live Voltage	<input type="checkbox"/>	<input type="checkbox"/>
Ground Fault Circuit Interrupters in Use	<input type="checkbox"/>	<input type="checkbox"/>
<b>5. Work Practices</b>		
Asbestos Material Worked Wet	<input type="checkbox"/>	<input type="checkbox"/>
Removed Material Promptly Bagged	<input type="checkbox"/>	<input type="checkbox"/>
Bags Properly Labeled and Gooseneck Sealed	<input type="checkbox"/>	<input type="checkbox"/>
HEPA Vacuum Used	<input type="checkbox"/>	<input type="checkbox"/>
Work Area Cleaned at End of Shift	<input type="checkbox"/>	<input type="checkbox"/>
Workers Decontaminated at Each Departure	<input type="checkbox"/>	<input type="checkbox"/>
No Smoking, Eating, or Drinking in Containment	<input type="checkbox"/>	<input type="checkbox"/>
<b>6. Personnel Protection</b>		
Medical Examination and Training Conducted	<input type="checkbox"/>	<input type="checkbox"/>
Air Sampling Conducted and Posted	<input type="checkbox"/>	<input type="checkbox"/>
Disposable Clothing Worn Correctly	<input type="checkbox"/>	<input type="checkbox"/>
Torn Disposable Clothing Replaced Promptly	<input type="checkbox"/>	<input type="checkbox"/>
Appropriate NIOSH-Approved Respirators in Use	<input type="checkbox"/>	<input type="checkbox"/>
Respirators Inspected and Cleaned Daily	<input type="checkbox"/>	<input type="checkbox"/>
Hard Hats Work Correctly (Where Applicable)	<input type="checkbox"/>	<input type="checkbox"/>
Safety Harnesses Worn Correctly (Where Applicable)	<input type="checkbox"/>	<input type="checkbox"/>
<b>7. Decontamination</b>		
Showers on Site and Functioning Properly	<input type="checkbox"/>	<input type="checkbox"/>
Adequate Soap and Towels Available	<input type="checkbox"/>	<input type="checkbox"/>
All Workers Showering Correctly	<input type="checkbox"/>	<input type="checkbox"/>
Water Filtration System in Operation	<input type="checkbox"/>	<input type="checkbox"/>

**8. Comments:**

---

---

---

---



## EQUIPMENT OPERATOR SKILLS EVALUATION - CONVENTIONAL CRANE

Name (Print) Last, F.M.	Employee Number	Date of Evaluation	Project Name & Number
Driver's License Copied	<input type="checkbox"/> Yes <input type="checkbox"/> No	Operator's Card Copied	<input type="checkbox"/> Yes <input type="checkbox"/> No
Was Operator Licensed?	If NO, state reason:		
<input type="checkbox"/> Yes <input type="checkbox"/> No			
Manufacturer	Model	Serial Number	Capacity
Crane Type (check one)		Boom Length	
<input type="checkbox"/> Crawler <input type="checkbox"/> Truck <input type="checkbox"/> Self-Propelled		MAIN- <span style="margin-left: 100px;">JIB-</span>	
Annual Inspection Verified?	Date of Inspection	Acceptance Inspection Completed	Date of Inspection
<input type="checkbox"/> Yes <input type="checkbox"/> No		<input type="checkbox"/> Yes <input type="checkbox"/> No	
Operator's Signature		Evaluator's Signature	















- Notes:
- 1) If any questions above are "NO", do not continue evaluation.
  - 2) Machine shall be located in a designated test area prior to beginning this evaluation.
  - 3) Caution should be exercised to ensure that the equipment being used in this evaluation is safe and in good operable condition when furnished to operator for evaluation.
  - 4) The operator is required to pass the skills evaluation with 100% accuracy.

PRE-START INSPECTION	PASS	FAIL	N/A	COMMENTS
1) Engine oil level				
2) Coolant level				
3) Transmission oil level				
4) Battery condition and connections				
5) Fuel level				
6) Check for fluid leaks (oil, water, transmission, etc.)				
7) Condition of belts (fan, pumps, etc.)				
8) Locate and check master electrical disconnect switch (for emergency shutdown use only)				

SETUP	PASS	FAIL	N/A	COMMENTS
1) Locate and identify all brakes (parking, swing, etc.)				
2) Transmission and all controls in neutral position				
3) Locate engine emergency shutdown				
a) Ensure fire extinguisher is installed and serviced				
4) Start engine				
5) Check all gauges for proper operation				
6) Allow engine and transmission oil to warm up to operating temperature and check for air and oil leaks				
7) Visual safety inspection of wire rope and connections, block(s), support chokers				
8) Lower outriggers and level machine (if applicable) Note: Tires should clear the ground				
9) Locate load charts and demonstrate proper use Note: From the load charts, using a 20" radius (without Riggers extended, if applicable), select:				
a) Maximum capacity of the machine				
b) Correct boom length				
c) Correct boom angle				
d) Determination of net load weight				



**Table F-1 FIRE EXTINGUISHERS DATA**

	WATER TYPE				FOAM	CARBON DIOXIDE	DRY CHEMICAL			
							SODIUM OR POTASSIUM BICARBONATE	MULT-PURPOSE ABC		
										
<b>CLASS A</b> FIRES WOOD, PAPER, TRASH HAVING GLOWING EMBERS 	YES	YES	YES	YES	YES	NO (BUT WILL CONTROL SMALL SURFACE FIRES)	NO (BUT WILL CONTROL SMALL SURFACE FIRES)	NO (BUT WILL CONTROL SMALL SURFACE FIRES)	YES	YES
<b>CLASS B</b> FIRES FLAMMABLE LIQUIDS, GASOLINE, OIL, PAINTS, GREASE, ETC. 	NO	NO	NO	NO	YES	YES	YES	YES	YES	YES
<b>CLASS C</b> FIRES ELECTRICAL EQUIPMENT 	NO	NO	NO	NO	NO	YES	YES	YES	YES	YES
<b>CLASS D</b> FIRES COMBUSTIBLE METALS 	<b>SPECIAL EXTINGUISHING AGENTS APPROVED BY RECOGNIZED TESTING</b>									
<b>METHOD OF OPERATION</b>	PULL PIN-SQUEEZE HANDLE	TURN UPSIDE DOWN AND BUMP	PUMP HANDLE	TURN UPSIDE DOWN	TURN UPSIDE DOWN	PULL PIN-SQUEEZE LEVER	RUPTURE CARTRIDGE-SQUEEZE LEVER	PULL PIN-SQUEEZE HANDLE	PULL PIN-SQUEEZE HANDLE	RUPTURE CARTRIDGE-SQUEEZE LEVER
<b>RANGE</b>	30' - 40'	30' - 40'	30' - 40'	30' - 40'	30' - 40'	3' - 8'	5' - 30'	5' - 30'	5' - 30'	5' - 30'
<b>MAINTENANCE</b>	CHECK AIR PRESSURE GAUGE MONTHLY	WEIGH GAS CARTRIDGE AND ADD WATER IF REQUIRED ANNUALLY	DISCHARGE AND FILL WITH WATER ANNUALLY	DISCHARGE ANNUALLY-RECHARGE	DISCHARGE ANNUALLY-RECHARGE	WEIGH SEND ANNUALLY	WEIGH GAS CARTRIDGE-CHECK CONDITION OF DRY CHEMICAL ANNUALLY	CHECK GAS PRESSURE GAUGE AND CONDITION OF DRY CHEMICAL ANNUALLY	CHECK GAS PRESSURE GAUGE AND CONDITION OF DRY CHEMICAL ANNUALLY	WEIGH GAS CARTRIDGE-CHECK CONDITION OF DRY CHEMICAL ANNUALLY

### Helicopter Lift Checklist

		Yes	No	N/A
1.	Has briefing been conducted with pilot and ground crew?	<input type="checkbox"/>	<input type="checkbox"/>	<input type="checkbox"/>
2.	Is weight of load within manufacturer's lift rating?	<input type="checkbox"/>	<input type="checkbox"/>	<input type="checkbox"/>
3.	Are hoist wires free from fouling on any fixed structure?	<input type="checkbox"/>	<input type="checkbox"/>	<input type="checkbox"/>
4.	Have aircrew and ground crew been briefed on signal systems in advance of lift?	<input type="checkbox"/>	<input type="checkbox"/>	<input type="checkbox"/>
5.	Has a worker been designated as the signalman during loading/unloading?	<input type="checkbox"/>	<input type="checkbox"/>	<input type="checkbox"/>
6.	Is the signalman distinctly recognizable from the other ground crew?	<input type="checkbox"/>	<input type="checkbox"/>	<input type="checkbox"/>
7.	Have workers been told to only approach helicopter from the sides in a crouched position and in full view of the pilot?	<input type="checkbox"/>	<input type="checkbox"/>	<input type="checkbox"/>
8.	Are enough workers provided for safe load/unload operations?	<input type="checkbox"/>	<input type="checkbox"/>	<input type="checkbox"/>
9.	Has a helicopter operator who will be responsible for the size, weight and <u>manner in which</u> loads are connected been assigned?	<input type="checkbox"/>	<input type="checkbox"/>	<input type="checkbox"/>
10.	Has the entire area under the lift path been cordoned off?	<input type="checkbox"/>	<input type="checkbox"/>	<input type="checkbox"/>
11.	Has the area inside the building under the lift path been cordoned off?	<input type="checkbox"/>	<input type="checkbox"/>	<input type="checkbox"/>
12.	Is the area free from any open fires?	<input type="checkbox"/>	<input type="checkbox"/>	<input type="checkbox"/>
13.	Has a safe means of access been provided for workers to the hoist line hook for engagement/release of cargo slings?	<input type="checkbox"/>	<input type="checkbox"/>	<input type="checkbox"/>
14.	Is all loose gear within 100' of lift and target secured or removed?	<input type="checkbox"/>	<input type="checkbox"/>	<input type="checkbox"/>
15.	Is visibility reduced by dust or other conditions?	<input type="checkbox"/>	<input type="checkbox"/>	<input type="checkbox"/>
16.	Are tag lines short enough to prevent them from being drawn up into the rotors?	<input type="checkbox"/>	<input type="checkbox"/>	<input type="checkbox"/>
17.	Are all cable connections either pressed sleeve or wedged eyes?	<input type="checkbox"/>	<input type="checkbox"/>	<input type="checkbox"/>
18.	Are electrically operated cargo hooks designed to prevent inadvertent operation?	<input type="checkbox"/>	<input type="checkbox"/>	<input type="checkbox"/>
19.	Do cargo hooks have an emergency mechanical control for releasing the load?	<input type="checkbox"/>	<input type="checkbox"/>	<input type="checkbox"/>
20.	Have cargo hooks been tested today to determine that the release functions properly?	<input type="checkbox"/>	<input type="checkbox"/>	<input type="checkbox"/>
21.	Is ground crew wearing goggles?	<input type="checkbox"/>	<input type="checkbox"/>	<input type="checkbox"/>
22.	Is ground crew free of <u>loose fitting</u> clothing which may be snagged in hoist line?	<input type="checkbox"/>	<input type="checkbox"/>	<input type="checkbox"/>
23.	Are workers clear of hovering craft except when necessary to hook/unhook loads?	<input type="checkbox"/>	<input type="checkbox"/>	<input type="checkbox"/>
24.	Has static charge been dissipated with a grounding device before workers touch the suspended load?	<input type="checkbox"/>	<input type="checkbox"/>	<input type="checkbox"/>
25.	Are protective rubber gloves worn by all ground crew touching the suspended non-grounded load?	<input type="checkbox"/>	<input type="checkbox"/>	<input type="checkbox"/>
26.	Are unauthorized workers kept at least 50' from helicopter when rotor blades are turning?	<input type="checkbox"/>	<input type="checkbox"/>	<input type="checkbox"/>

Location of Lift: \_\_\_\_\_

Observed By: \_\_\_\_\_ Date: \_\_\_\_\_



**DO NOT ENTER**

**HELICOPTER LIFT**

**IN PROGRESS**



### Helicopter Lift Notification

Project Number: \_\_\_\_\_

Project name: \_\_\_\_\_

Date: \_\_\_\_\_

Lift Supervisor: \_\_\_\_\_

Signature

_____ Project Manager	_____
_____ Corporate Safety	_____
_____ Facilities	_____
_____ Facilities	_____
_____ Project Superintendent	_____
_____ Maintenance Manager	_____
_____ Maintenance Manager	_____
_____ Facility Security	_____
_____ Safety Representative	_____

Contractor's name: \_\_\_\_\_ Site Project Manager: \_\_\_\_\_

Name of Helicopter Company: \_\_\_\_\_ Initial Date of Flight: \_\_\_\_\_

Time of Flight: \_\_\_\_\_ No of Picks: \_\_\_\_\_ Contingency Date: \_\_\_\_\_

Lift Description:

\_\_\_\_\_  
\_\_\_\_\_  
\_\_\_\_\_

Attachments: Helicopter Submittal Form

\_\_\_\_\_ Helicopter Company Job Detail Checklist

- Flight Plan
- Contractor's Insurance Certificate
- Helicopter Safety Procedure
- Helicopter Lift Check List
- Notification of Authorities Form
- Helicopter Lift in Progress Sign



Helicopter Lift Notification  
**Notification To Authorities**

---

**PROJECT NUMBER:** \_\_\_\_\_ **PROJECT NAME:** \_\_\_\_\_

ONLY A PHONE CALL IS REQUIRED, NOT A SIGNATURE

The following people and agencies have been notified that \_\_\_\_\_ HELICOPTER will be conducting a helicopter external lift operation at the below named location.

**Police Department:** Officer's Name: \_\_\_\_\_

City: \_\_\_\_\_ Telephone: \_\_\_\_\_

**Fire Department:** Officer's Name: \_\_\_\_\_

City: \_\_\_\_\_ Telephone: \_\_\_\_\_

**Contractor:** Contact Person: \_\_\_\_\_

Company: \_\_\_\_\_ Telephone: \_\_\_\_\_

**Jobsite Information:** Name of Building: \_\_\_\_\_

Address: \_\_\_\_\_

\_\_\_\_\_ County \_\_\_\_\_

**Date And Time Of Operation:** \_\_\_\_\_

**Agreement to Provide a Secure Area During Helicopter External Lift Operations**

Company Representative, Security Department, Police or Sheriff named below agrees to provide necessary security to exclude unauthorized persons from the jobsite during the helicopter lift operation.

Name: \_\_\_\_\_

Title: \_\_\_\_\_

Department/Office: \_\_\_\_\_

Telephone: \_\_\_\_\_

**Job Contact For Pilot's Use:** Name: \_\_\_\_\_ Day Phone: \_\_\_\_\_

\_\_\_\_\_ Evening Phone: \_\_\_\_\_

The above information is required By Federal Aviation Regulations. This sheet needs to be filled out in its entirety.



### HELICOPTER LIFT NOTIFICATION

#### JOB DETAIL CHECKLIST

Please complete all information and return this form to our office.

PROJECT NUMBER: \_\_\_\_\_ PROJECT NAME: \_\_\_\_\_

Roof Completed: \_\_\_\_\_ Roof Staging Area Cleaned Up? \_\_\_\_\_  
(Loose material, insulation, plywood, etc.)

Type of Roof: \_\_\_\_\_ Tall Obstructions: \_\_\_\_\_  
(List height and distance from)

No. of Men You'll Supply \_\_\_\_\_ Police/Security Obtained? \_\_\_\_\_  
(Minimum of 6 required) Any Light Poles? \_\_\_\_\_

Safety Glasses

Hard Hats

Chin Straps

Any Power Lines? \_\_\_\_\_ Any Isolators? \_\_\_\_\_  
(Distance from staging and set sights) (Must have cribbing for isolators)

Site Phones: \_\_\_\_\_

#### Equipment To Be Listed

Quantity	Description	Diameter	How Tall	Weight	Attachment Points

Number the units and corresponding curbs to avoid setting them in the wrong place or in the wrong place or in the wrong direction.

Contractor: \_\_\_\_\_ Site Phone Number: \_\_\_\_\_

Project Manager: \_\_\_\_\_ Date: \_\_\_\_\_



## Lead Rules Checklist

PROJECT NUMBER: \_\_\_\_\_

DATE: \_\_\_\_\_

PROJECT NAME: \_\_\_\_\_

### 1. Exposure Monitoring

#### Initial Determination:

- Was initial monitoring conducted for a representative sample of employees? \_\_\_\_\_  
When? \_\_\_\_\_ By whom? \_\_\_\_\_
- If there was a positive determination ( $\geq$  action level), was **each** employee so exposed monitored? \_\_\_\_\_
- If there was a negative determination ( $<$  action level), are proper written records maintained? \_\_\_\_\_
- Were the employees notified? \_\_\_\_\_

#### Continued Determination:

- Were the exposures greater than or equal to the action level but less than the PEL? \_\_\_\_\_  
If yes, was monitoring repeated every 6 months? \_\_\_\_\_  
By whom? \_\_\_\_\_
- Were the exposures greater than the PEL? \_\_\_\_\_  
If yes, was monitoring repeated every 3 months? \_\_\_\_\_  
By whom? \_\_\_\_\_
- Were all affected employees notified of the results? \_\_\_\_\_  
In writing? \_\_\_\_\_  
Within five working days of results received? \_\_\_\_\_  
If the PEL was exceeded, was a description of the corrective actions included in the notification? \_\_\_\_\_
- Was all monitoring sufficiently accurate? \_\_\_\_\_  
Documentation? \_\_\_\_\_
- Have there been any production, process, control or employee changes which could affect the exposures? \_\_\_\_\_  
If yes, was additional monitoring conducted? \_\_\_\_\_  
When? \_\_\_\_\_  
By whom? \_\_\_\_\_

### 2. Compliance

#### Exposure Duration:

- Are exposures greater than eight hours per day? \_\_\_\_\_
- If yes, PEL = 40/hour worked. Actual PEL = \_\_\_\_\_

- Are exposures greater than 30 days per year? \_\_\_\_\_

**Engineering Controls:**

- Have engineering controls been implemented? \_\_\_\_\_

List: \_\_\_\_\_

- Are additional engineering controls feasible? \_\_\_\_\_

List: \_\_\_\_\_

**Work Practice Programs:**

- Has a written practice program been established? \_\_\_\_\_

- If yes, what does it include? \_\_\_\_\_

**Respirators:**

- Are respirators provided and used by all employees whose exposures exceed the PEL? \_\_\_\_\_

- Are respirators provided for any employees who request them? \_\_\_\_\_

**3. Respiratory Protection (When Respirators are Provided)**

**Selection:**

- What types of respirators are provided? \_\_\_\_\_

- Are they approved? \_\_\_\_\_

If yes, approval numbers: \_\_\_\_\_

- Do they meet the requirements of Table 3 Lead Rules? \_\_\_\_\_

If not, why? \_\_\_\_\_

**Respiratory Protection Program:**

- Is an acceptable respiratory protection program implemented? \_\_\_\_\_

- Who administers it? \_\_\_\_\_

Are there written procedures for use and selections? \_\_\_\_\_

Are the employees trained in respirator use and limitations? \_\_\_\_\_

Are the respirators for exclusive employee use? \_\_\_\_\_

Are respirators satisfactorily cleaned and disinfected? \_\_\_\_\_

(Daily for "exclusive use" respirators and after each use for "common use" respirators)

Are the respirators inspected during cleaning? \_\_\_\_\_

If emergency respirators are provided, are they inspected monthly and after each use? \_\_\_\_\_

Are respirators stored properly? \_\_\_\_\_

Has it been determined that all employees who wear respirators are physically able to do so? \_\_\_\_\_

Is the work area and degree of exposure regularly surveyed? \_\_\_\_\_

How often? \_\_\_\_\_

Is the program periodically reviewed? \_\_\_\_\_

**Fit Testing:**

- Are qualitative fit tests performed? \_\_\_\_\_

If yes, what type? \_\_\_\_\_ How often? \_\_\_\_\_

- Are quantitative fit tests performed? \_\_\_\_\_

If yes, what type? \_\_\_\_\_ How often? \_\_\_\_\_

- Who conducts the above tests? \_\_\_\_\_

**4. Protective Clothing**

**Types:**

- Are full body covering provided at no cost to the employee? \_\_\_\_\_
- Are shoes, shoe coverings or gloves provided? \_\_\_\_\_
- Is any other PPE, such as goggles or face shields provided? \_\_\_\_\_

**Cleaning Replacement and Storage:**

- Is replacement work clothing provided each day for all employees whose exposure exceeds 200  $\mu\text{g}/\text{m}^3$ ? \_\_\_\_\_
- Is replacement work clothing provided for all employees whose exposures exceed the PEL but are less than 200  $\mu\text{g}/\text{m}^3$ ? \_\_\_\_\_
- Is the protective clothing removed at the end of each shift? \_\_\_\_\_
- Is the removal of lead from the protective clothing by blowing and shaking prohibited? \_\_\_\_\_
- Is contaminated protective clothing stored in closed containers? \_\_\_\_\_
- Are the containers labeled appropriately? \_\_\_\_\_
- Has the person who cleans the clothing been informed, in writing, of the potentially harmful effects of lead? \_\_\_\_\_

**5. Housekeeping**

**Work Surfaces:**

- Are all work surfaces maintained as free as practicable from lead accumulations? \_\_\_\_\_
- If not, list locations of accumulations: \_\_\_\_\_

**Floors and Cleaning:**

- Is compressed air used to clean floors or other surfaces? \_\_\_\_\_
- Is dry sweeping, shoveling or brushing used to clean surfaces? \_\_\_\_\_
- Is vacuuming used to clean the workplace? \_\_\_\_\_

- Is the vacuum cleaner selected, used and emptied in a manner that minimizes the re-entry of lead into the workplace? \_\_\_\_\_  
List types of vacuums and procedures for use and emptying? \_\_\_\_\_

- If vacuuming is not used, why not? \_\_\_\_\_
- Has vacuuming been attempted? \_\_\_\_\_

**6. Hygiene Facilities**

**Personal Items:**

- Are smoking, beverage and food consumption and cosmetics prohibited in areas where exposures exceed the PEL? \_\_\_\_\_
- If they are not prohibited, list the areas: \_\_\_\_\_

**Change Rooms:**

- Where available, are change rooms used by all employees whose exposures exceed the PEL? \_\_\_\_\_
- Are separate lockers for work and street clothing provided? \_\_\_\_\_
- Does all work clothing remain at the workplace? \_\_\_\_\_

**Showers:**

- Where available, are showers used by all employees whose exposures exceed the PEL? \_\_\_\_\_

**Personal Hygiene:**

- Are all employees whose exposures exceed the PEL required to wash their hands and face before eating, drinking, smoking or applying cosmetics? \_\_\_\_\_
- Was this observed? \_\_\_\_\_

**Lunchrooms:**

- Are lunchrooms provided? \_\_\_\_\_
- Are they free of significant lead accumulations? \_\_\_\_\_
- Do employees wear their work clothing in the lunchroom? \_\_\_\_\_

**7. Medical Surveillance** (Applies to all employees exposed at or above the action level for more than 30 days per year)

**Biological Monitoring:**

- Is blood lead monitoring available at no cost to the employees? \_\_\_\_\_
- Every 6 months for each employee? \_\_\_\_\_
- Every 2 months for each employee whose blood lead level is at or above \_\_\_\_\_

40 µg/100 g? \_\_\_\_\_

- At least monthly for any employee removed from lead exposure due to elevated blood lead level? \_\_\_\_\_
- Who performs the blood lead analyses? \_\_\_\_\_
- Is it an accepted laboratory? \_\_\_\_\_

Are employees whose blood leads exceed 40 µg/100 g notified, in writing, of the results? \_\_\_\_\_

Information relative to medical removal? \_\_\_\_\_

**Medical Examinations:**

- Are medical exams available at no cost to the employees? \_\_\_\_\_
- How often? \_\_\_\_\_
- Who performs them? \_\_\_\_\_
- Does the exam include the following:

Detailed work and medical history? \_\_\_\_\_

Thorough physical exam? \_\_\_\_\_

Blood pressure? \_\_\_\_\_

Blood sample and analysis for:

- Blood lead? \_\_\_\_\_
- Cell indices? \_\_\_\_\_
- Urea nitrogen? \_\_\_\_\_
- Serum creatine? \_\_\_\_\_

Urinalysis? \_\_\_\_\_

- Any other tests deemed necessary by the physician? \_\_\_\_\_

**Information to the Physician:**

Is the following information provided to the consulting physician?

Lead rules and appendices? \_\_\_\_\_

Work descriptions? \_\_\_\_\_

Exposure concentrations? \_\_\_\_\_

Description of personal protective equipment used? \_\_\_\_\_

Prior blood lead determination? \_\_\_\_\_

Prior medical opinions? \_\_\_\_\_

**Written Medical Opinions:**

- Does the consulting physician prepare a written medical opinion of each employee? \_\_\_\_\_
- Is a copy provided to each employee? \_\_\_\_\_

**Alternate Physicians:**

- Has there been a request by the employer, employee or employee representative for an alternate physician determination? \_\_\_\_\_
- If yes, why? \_\_\_\_\_
- When? \_\_\_\_\_
- Was an alternate determination provided at no cost to the employee? \_\_\_\_\_

**Chelation:**

- Is prophylactic chelation performed? \_\_\_\_\_  
If yes, by whom? \_\_\_\_\_
- Is therapeutic chelation performed? \_\_\_\_\_  
If yes, under whose supervision? \_\_\_\_\_  
If yes, by whom? \_\_\_\_\_

**8. Medical Removal  
Elevated Blood Levels**

- Are any employees' blood levels in excess of 60 µg/100 g? \_\_\_\_\_  
If yes, were they removed from work where exposure equals or exceeds the action level? \_\_\_\_\_  
If yes, when? \_\_\_\_\_

**Final Medical Determination (Alternate Medical Determination)**

- Has any employee been removed from work at or above the action level due to an alternate medical determination? \_\_\_\_\_  
If yes, by whom? \_\_\_\_\_  
If yes, who was the alternate physician? \_\_\_\_\_
- Were any special recommendations included? \_\_\_\_\_  
If yes, what? \_\_\_\_\_

**Return to Former Job Status:**

- Has any employee returned to former job status following medical removal? \_\_\_\_\_
- If removal was due to elevated blood lead levels, were two consecutive blood lead levels less than 40 µg/100 g? \_\_\_\_\_
- If removal was due to final medical determination, was the employee determined to be no longer at risk? \_\_\_\_\_  
Who made this determination? \_\_\_\_\_

**Final Medical Determination Pending:**

- Has there been an alternate medical determination for an employee which did not result

in a final medical determination? \_\_\_\_\_

- What is the employees' status in the interim? \_\_\_\_\_

**Medical Removal Protection Benefits:** (Applies only to medically removed employees)

- Do the employees maintain earnings, seniority and benefits while medically removed? \_\_\_\_\_
- How much time is allowed for medical removal? \_\_\_\_\_
- Is follow-up medical surveillance provided? \_\_\_\_\_

If yes, does the employer require such surveillance as a condition to maintain medical removal benefits? \_\_\_\_\_

- Has any employee filed a workers' compensation claim regarding lead exposure? \_\_\_\_\_

If yes, did the employer continue to provide medical removal benefits until the disposition of the claim? \_\_\_\_\_

- If the employees' blood lead level exceeded 40 µg/100 g after 18 months, were any of the following provided:

A final medical determination? \_\_\_\_\_

Continued medical removal benefits until a final medical determination was obtained? \_\_\_\_\_

Return to former job status pending a final determination? \_\_\_\_\_

**9. Employee Information and Training**

**Rules:**

- Are the lead rule appendices A and B of these rules available to the employees? \_\_\_\_\_

If yes, in what manner? \_\_\_\_\_

**Information:**

- Are employees thoroughly informed about the following:  
Operations where lead exposures may occur? \_\_\_\_\_  
Respirators? \_\_\_\_\_  
Medical surveillance? \_\_\_\_\_  
Engineering and work practice controls? \_\_\_\_\_  
Contents of any compliance plan in effect? \_\_\_\_\_  
Chelating agents? \_\_\_\_\_

**10. Record-Keeping**

**Exposure Monitoring:**

- Does the employer maintain exposure monitoring records? \_\_\_\_\_
- If yes, do they include the following:

Dates, duration, location and sample results? \_\_\_\_\_

Description of sampling and analytical methods? \_\_\_\_\_

Type of respirators worn, if any? \_\_\_\_\_

Name, Social Security Number and job of the affected employee? \_\_\_\_\_

Any factors that could affect the exposure measurement? \_\_\_\_\_

- Is the employer aware that these records must be kept 40 years or for the duration of employment plus 30 years, whichever is longer? \_\_\_\_\_

**Medical Surveillance:**

- Does the employer maintain medical surveillance records? \_\_\_\_\_

- If yes, do they include the following:

Employee name, Social Security Number and job description? \_\_\_\_\_

Physician's written opinion? \_\_\_\_\_

Exposure monitoring results? \_\_\_\_\_

Employee medical complaints relative to lead exposure? \_\_\_\_\_

- Does the employer or examining physician maintain the following records:

Medical exam results? \_\_\_\_\_

Copy of lab procedures and guidelines used to interpret tests? \_\_\_\_\_

Biological monitoring results? \_\_\_\_\_

- Are the employer and physician aware that these records must be kept for the same duration specified in exposure monitoring? \_\_\_\_\_

**Medical Removals:**

- Does the employer maintain a record of all medical removals? \_\_\_\_\_

- If yes, do they include the following:

Name and Employee Number of the employee? \_\_\_\_\_

Dates of removal and return? \_\_\_\_\_

Brief explanation of the removal? \_\_\_\_\_

- Is the employer aware that these records must be maintained for at least the duration of employment? \_\_\_\_\_

**Availability of Records:**

- Are the above records available to the following persons:

Affected employees? \_\_\_\_\_

Former employees? \_\_\_\_\_

The Director? \_\_\_\_\_

Authorized employee representative? \_\_\_\_\_

**Transfer of Records:**

- Was there a previous employer at the work site? \_\_\_\_\_  
If yes, were all pertinent records transferred to the successor? \_\_\_\_\_  
If yes, when? \_\_\_\_\_

**11. Observation Of Monitoring**

- Are the affected employees or their representatives allowed the opportunity to observe exposure monitoring? \_\_\_\_\_
- Did the observers also obtain the following:  
Explanation of measurement procedures? \_\_\_\_\_  
Observations of all procedural steps at the place of employment? \_\_\_\_\_  
Copies of results? \_\_\_\_\_



## NON-PERMIT CONFINED SPACE ENTRY

Project Number: \_\_\_\_\_

Project Name: \_\_\_\_\_

Monitor (Make / Model / Serial Number): _____		Today's Date: _____		
Last Calibration Date: _____				
CONTAMINANT	TIME	RESULT	SIGNATURE OF PERSON CONDUCTING TEST	SIGNATURE OF WITNESS
% Oxygen (19.5-23.5)				
Lower Explosive Limit (LEL) (<10%)				
Hydrogen Sulfide (H <sub>2</sub> S) (<10 ppm)(8 hr day)				
Carbon Monoxide (CO) (<40 ppm)(8 hr day)				
CONTAMINANT	TIME	RESULT	SIGNATURE OF PERSON CONDUCTING TEST	SIGNATURE OF WITNESS
% Oxygen (19.5-23.5)				
Lower Explosive Limit (LEL) (<10%)				
Hydrogen Sulfide (H <sub>2</sub> S) (<10 ppm)(8 hr day)				
Carbon Monoxide (CO) (<40 ppm)(8 hr day)				
CONTAMINANT	TIME	RESULT	SIGNATURE OF PERSON CONDUCTING TEST	SIGNATURE OF WITNESS
% Oxygen (19.5-23.5)				
Lower Explosive Limit (LEL) (<10%)				
Hydrogen Sulfide (H <sub>2</sub> S) (<10 ppm)(8 hr day)				
Carbon Monoxide (CO) (<40 ppm)(8 hr day)				
CONTAMINANT	TIME	RESULT	SIGNATURE OF PERSON CONDUCTING TEST	SIGNATURE OF WITNESS
% Oxygen (19.5-23.5)				
Lower Explosive Limit (LEL) (<10%)				
Hydrogen Sulfide (H <sub>2</sub> S) (<10 ppm)(8 hr day)				
Carbon Monoxide (CO) (<40 ppm)(8 hr day)				

**NOTE: IF CONDITIONS ARE NOT IN COMPLIANCE WITH PERMIT OR IF THERE IS REASON TO SUSPECT THAT CONDITIONS HAVE CHANGED ADVERSELY, TERMINATE THE ENTRY.**

**ORIGINALS OR COPIES OF COMPLETED PERMITS ARE TO BE MAINTAINED AT WORKSITE.**



---

**To Be Posted on All Project Sites**  
**YOU HAVE A RIGHT TO KNOW ABOUT**  
**HAZARDOUS SUBSTANCES IN YOUR WORKPLACE**

**IT'S THE LAW!**

The OSHA Hazard Communication Standard gives employees a way to learn about chemical hazards in the workplace and how to work safely with these materials. OSHA requires employers to inventory and list all hazardous and toxic substances used in the workplace and to collect Safety Data Sheets for these substances. Employers must also label or otherwise identify hazardous chemicals. Employees must know how to get information about the hazardous substances in their workplace and be trained in the safe use of these materials.

---

We are complying with OSHA by compiling a chemical information list and Material Safety Data Sheets, checking that containers are labeled, and providing you with training.

- **Chemical Information List:** Our Chemical Information List contains all of the chemicals we are using at \_\_\_\_\_ (this project site). A copy of this list is available at each site. Your Foreman or Forewoman will generally have the list and may leave it at a central location, such as a project trailer. At this project site the list is available at \_\_\_\_\_. Lists of chemicals used by other employers on the site are also available to you. Check with your Project Manager for access to those lists.
- **Safety Data Sheets:** Safety Data Sheets for the chemicals used on this project are available at the following location: \_\_\_\_\_. If you need to review a data sheet, please see \_\_\_\_\_ (Name).

---

(Times and Location)

- **Labels:** The products we use are labeled in accordance with the Right-to-Know Law. They contain identification of any hazardous components and an appropriate hazard warning. Some of the products we use are consumer products and may not indicate the hazards of their use. When in doubt, see the list and Safety DataSheet.



**PROJECT HAZARDOUS MATERIAL INVENTORY LIST**

PROJECT NUMBER: \_\_\_\_\_ PROJECT NAME: \_\_\_\_\_

LOCATION: \_\_\_\_\_

DATE PROJECT BEGAN: \_\_\_\_\_

Comments/Concerns: SDS sheets are to be kept on the project for each chemical or hazardous material that are used on the Project and be available to all Alberici and subcontractor employees.

	Name	Material / Stored / Date
1.		
2.		
3.		
4.		
5.		
6.		
7.		
8.		
9.		
10.		
11.		
12.		
13.		
14.		
15.		
16.		
17.		
18.		
19.		
20.		
21.		
22.		
23.		
24.		
25.		
26.		
27.		
28.		
29.		

30.		
31.		
32.		
33.		
34.		
35.		
36.		
37.		
38.		
39.		
40.		
41.		
42.		
43.		
44.		
45.		
46.		
47.		
48.		
49.		
50.		



### AERIAL WORK PLATFORM DAILY INSPECTION LOG

Before equipment operation on each work shift, the aerial work platform and area of planned usage shall be given a visual inspection by the operator for equipment defects and the location of hazards that could affect the equipment's safe operation and use.

**Operators must be trained to inspect and operate the unit in accordance with local/state/federal requirements**

Equipment Type: \_\_\_\_\_ Model: \_\_\_\_\_ Project: \_\_\_\_\_  
Manufacturer: \_\_\_\_\_ Serial/ID#: \_\_\_\_\_ Contractor: \_\_\_\_\_

WEEK of : \_\_\_\_\_

Sun	Mon	Tue	Wed	Thurs	Fri	Sat
-----	-----	-----	-----	-------	-----	-----

**A Checkmark (✓) in box indicates SATISFACTORY - WRITE IN ANY UNSATISFACTORY FINDINGS IN COMMENT SECTION BELOW. DO NOT OPERATE IF UNIT OR SITE CONDITIONS FAIL INSPECTION. NOTIFY SUPERVISOR & RED TAG UNIT IF UNSATISFACTORY.**

EQUIPMENT INSPECTION							
1. Operating and emergency controls							
2. Safety Devices and designed fall protection tie-off points							
3. Fuel, hydraulic and battery water levels							
4. Air, fuel and hydraulic lines							
5. Cables and wiring harnesses							
6. Associated equipment parts and assemblies (Check for damage)							
7. Tires and wheels (proper inflation and condition)							
8. Equipment welds (check for any cracked welds)							
9. Structural members (check for bent or broken members)							
10. Outriggers, stabilizers, extendible axles and other relevant components							
11. Warning and control decals or placards (present and legible)							
12. Guardrail system, safety gates and chains							
13. Platform condition (platform is free of slip and trip hazards)							
14. Operating and Safety Manual Available & Legible							
15. Correct Personal Protective Equipment in place (PPE)							
SITE INSPECTION							
Ditches or trenches							
Drop-offs, slopes, and extreme elevation changes							
Holes							
Bumps, floor obstructions or protrusions							
Overhead power lines or other electrical conductors							
Wind and inclement weather							
Other equipment or personnel affecting operation of aerial lift							
Sufficient clearance							
Surface capable of supporting the equipment in all operating configurations							
Additional Comments:							

I have read and reviewed the operator's manual and inspected this unit prior in accordance with the above check list prior to operating it and acknowledge that I am authorized by my company to use this piece of equipment. If I find that the unit fails inspection I know I must not operate it until corrections have been made to the equipment or site conditions.

	Name of INSPECTING OPERATOR (PRINT)	INITIALS	DATE
1			
2			
3			
4			
5			
6			
7			
8			
9			
10			
11			
12			
13			
14			



## SUSPENDED SCAFFOLDING: Inspection Checklist

---

### GENERAL GUIDELINES:

- Each occupant has read and understands the manufacturers operating and instruction manual.
- Ensure that all manufacturers' installation and usage rules are met.
- Ensure installation was done under the guidance of a "competent person."

" Name: \_\_\_\_\_

### ROOF SUPPORT SYSTEM:

- The parapet and other roofing parts are strong enough to support the weight.
- If the scaffold is counterbalanced, ensure there is a 4:1 safety margin.
- The counterweight material is bolted to the beam and cannot be displaced. Sand bags or other flowable materials are not allowed for counterweights.
- All tiebacks are made to a strong-safe part of the building. Do not make tiebacks to roof-top ducts or vents. Tiebacks should be as close to 90° with face of the structure as possible.

### SCAFFOLD PLATFORM:

- Inspect all parts of the scaffold;
  - stirrups
  - deck
  - rungs
  - rails
  - bumper rollers
  - welds
  - connections
  - toe boards
  - guardrails are sound and properly installed
- Scaffold does not exceed the load rating for the platform, hoists, and roof beams.
- Stirrups are *exactly* under the roof supports and the wire ropes hang straight down.

### HOIST OPERATION:

- A copy of the manufacturers operating instructions is on the stage. Operators have read and understand it.
- Hoists have been properly maintained and serviced.
- All warning, operation tags, and signs are visible and readable.
- Both wire ropes must be inspected and found in good condition. (must be long enough to reach the round)
- Leftover cable must be coiled at the top to protect it from damage.
- Inspect the scaffold's functionality by lifting it a few feet off the ground. (see bullet points below)
- Re-check all bolts and wire rope clamps.
- The cable is of sufficient size for the load being carried.
- Inspect the electric cable for damage.
- Voltage is correct for the hoist.
- Strain relief devices are installed at the connections.

### FALL ARREST SYSTEM:

- Each person on the scaffold has a separate lifeline system.  
(lifeline system must be installed to an anchorage separate of the scaffold)
- Anchorage point is adequate for a vertical lifeline system.
- Lifeline is protected from abrasion at the rooftop or parapet edge.
- Rope grabs are of the proper size for the rope being used.
- All components including the full body harness and lanyard are inspected and free from defects.
- Each** employee working on a suspended scaffold, is properly connected to their own lifeline system.  
(Do not allow tie off to the scaffolding)



**ADDITIONAL CHECKS: (Cover these items with scaffold users)**

- Ensure that all parts of the scaffolding, its cables, lifelines, rigging or work tools are **never closer than ten feet from any power lines.**
- Observe wind and weather conditions. Never use during periods of high wind and always ensure the platform is secured to reduce sway.
- Inspect the wire rope clips and rigging every day before it is used, or after moving it.
- The platform should always remain level as it is raised or lowered.
- If the scaffold hangs up on the structure, stop immediately where you are and call for help.
- Means of communication with the ground (i.e. radio, air horn, etc.) is in use when operating at great heights.

**Notes:**

---

---

---

**Contractor:** \_\_\_\_\_  
\_\_\_\_\_

**Date:**



## Silica Exposure Plan

**Date:** \_\_\_\_\_ **Company:** \_\_\_\_\_ **Silica Person:** \_\_\_\_\_ **Competent** \_\_\_\_\_

Task Description	
Location: _____	<input type="checkbox"/> Indoor <input type="checkbox"/> Outdoor
Duration: # of shifts: _____	<input type="checkbox"/> < 4 hours/shift <input type="checkbox"/> > 4 hours/shift
List materials that may contain silica, tools that may create airborne dust, and a description of the work process:	
_____	
_____	

Table 1 Compliance
Can this task be performed according to Table 1, with the specified controls fully and properly implemented?
<input type="checkbox"/> Yes <input type="checkbox"/> No (Air monitoring or objective data required. Consult Safety.)

Objective Data & Air Monitoring
Select the justification method for exposure controls. Air monitoring and objective data must reflect work conditions for this task (e.g. equipment, processes, material, % silica, environment). Attach documentation or maintain on file.
<input type="checkbox"/> Objective Data will be used <input type="checkbox"/> Table 1 will be used <input type="checkbox"/> Air monitoring data will be used
Description & Source: _____ <input type="checkbox"/> Air monitoring data not available

Engineering & Work Practice Controls
Prior to use, tool and equipment must be inspected for damage, secure hose connections, holes, kinks/pinches, leaks, clean filters, and properly fitting shrouds/cowls. Equipment must be operated, cleaned and maintained in accordance with manufacturer's instructions to minimize dust emissions.
<input type="checkbox"/> Dust Collection <input type="checkbox"/> Exhaust Ventilation w/HEPA <input type="checkbox"/> Wet Methods: _____
<input type="checkbox"/> Integrated Water Feed <input type="checkbox"/> Enclosed Cab, Cabin Filter <input type="checkbox"/> Other: _____

Housekeeping
Compressed air and dry sweeping shall not be used to remove dust and debris containing silica. Dispose of silica-containing vacuum bags, dust and debris in a sealed container (e.g. sealed garbage bag).
<input type="checkbox"/> Wet Sweeping <input type="checkbox"/> HEPA Vacuum <input type="checkbox"/> Water/Wet Washing
<input type="checkbox"/> Sweeping Compound <input type="checkbox"/> Other: _____

Work Area Access
Restrict access to the area(s) near the work where respirable crystalline silica exposure could reasonably be expected to exceed the action level of 25 ug/m <sup>3</sup> .
<input type="checkbox"/> No Restrictions <input type="checkbox"/> Signs <input type="checkbox"/> DANGER Barricade & Sign/Tag
<input type="checkbox"/> Spotter <input type="checkbox"/> Enclosure (sealed tent) <input type="checkbox"/> Other: _____

Respiratory Protection
Verify respiratory training and fit testing for respiratory protection users. Medical surveillance is required for individuals who use respirators under the silica rule for 30 or more days per year.
<input type="checkbox"/> N/A <input type="checkbox"/> ½ Face APR with P100 <input type="checkbox"/> Full Face APR with P100 <input type="checkbox"/> Other: _____



## Silica Exposure Plan

Additional Comments

**Supervisor Name:** \_\_\_\_\_ **Signature:** \_\_\_\_\_

Silica training and a review of this Silica Exposure Control Plan are required for employees involved in and directly supporting the silica work activity. Review of this plan is required annually and when work conditions change.

### Table 1

When performing multiple Table 1 tasks whose combined duration is greater than 4 hours, the respiratory protection specified in the >4 hours/shift column must be used for each respective task. Table 1 originates in 29 CFR 1926.1153(c)(1).

Equipment/task	Engineering and work practice control methods	Required respiratory protection and minimum assigned protection factor (APF)	
		≤ 4 hours/shift	>4 hours/shift
(i) Stationary masonry saws	Use saw equipped with integrated water delivery system that continuously feeds water to the blade Operate and maintain tool in accordance with manufacturer's instructions to minimize dust emissions	None	None
(ii) Handheld power saws (any blade diameter)	Use saw equipped with integrated water delivery system that continuously feeds water to the blade Operate and maintain tool in accordance with manufacturer's instructions to minimize dust emissions:  -When used outdoors  -When used indoors or in an enclosed area	None  APF 10	None  APF 10
(iii) Handheld power saws for cutting fiber-cement board (with blade diameter of 8 inches or less)	For tasks performed outdoors only: Use saw equipped with commercially available dust collection system Operate and maintain tool in accordance with manufacturer's instructions to minimize dust emissions Dust collector must provide the air flow recommended by the tool manufacturer, or greater, and have a filter with 99% or greater efficiency	None	None
(iv) Walk-behind saws	Use saw equipped with integrated water delivery system that continuously feeds water to the blade Operate and maintain tool in accordance with manufacturer's instructions to minimize dust emissions:  -When used outdoors	None	None



## Silica Exposure Plan

Equipment/task	Engineering and work practice control methods	Required respiratory protection and minimum assigned protection factor (APF)	
		≤ 4 hours/shift	>4 hours/shift
	-When used indoors or in an enclosed area	APF 10	APF 10
(v) Drivable saws	For tasks performed outdoors only: Use saw equipped with integrated water delivery system that continuously feeds water to the blade Operate and maintain tool in accordance with manufacturer's instructions to minimize dust emissions	None	None
(vi) Rig-mounted core saws or drills	Use tool equipped with integrated water delivery system that supplies water to cutting surface Operate and maintain tool in accordance with manufacturer's instructions to minimize dust emissions	None	None
(vii) Handheld and stand-mounted drills (including impact and rotary hammer drills)	Use drill equipped with commercially available shroud or cowling with dust collection system Operate and maintain tool in accordance with manufacturer's instructions to minimize dust emissions Dust collector must provide the air flow recommended by the tool manufacturer, or greater, and have a filter with 99% or greater efficiency and a filter-cleaning mechanism Use a HEPA-filtered vacuum when cleaning holes	None	None
(viii) Dowel drilling rigs for concrete	For tasks performed outdoors only: Use shroud around drill bit with a dust collection system. Dust collector must have a filter with 99% or greater efficiency and a filter-cleaning mechanism Use a HEPA-filtered vacuum when cleaning holes	APF 10	APF 10
(ix) Vehicle-mounted drilling rigs for rock and concrete	Use dust collection system with close capture hood or shroud around drill bit with a low-flow water spray to wet the dust at the discharge point from the dust collector	None	None
	OR Operate from within an enclosed cab and use water for dust suppression on drill bit	None	None
(x) Jackhammers and handheld powered chipping tools	Use tool with water delivery system that supplies a continuous stream or spray of water at the point of impact:		
	-When used outdoors  -When used indoors or in an enclosed area	None  APF 10	APF 10  APF 10



## Silica Exposure Plan

Equipment/task	Engineering and work practice control methods	Required respiratory protection and minimum assigned protection factor (APF)	
		≤ 4 hours/shift	>4 hours/shift
	<p>OR</p> <p>Use tool equipped with commercially available shroud and dust collection system</p> <p>Operate and maintain tool in accordance with manufacturer's instructions to minimize dust emissions</p> <p>Dust collector must provide the air flow recommended by the tool manufacturer, or greater, and have a filter with 99% or greater efficiency and a filter-cleaning mechanism:</p> <p>-When used outdoors</p> <p>-When used indoors or in an enclosed area</p>	<p>None</p> <p>APF 10</p>	<p>APF 10</p>
(xi) Handheld grinders for mortar removal ( <i>i.e.</i> , tuckpointing)	<p>Use grinder equipped with commercially available shroud and dust collection system</p> <p>Operate and maintain tool in accordance with manufacturer's instructions to minimize dust emissions</p> <p>Dust collector must provide 25 cubic feet per minute (cfm) or greater of airflow per inch of wheel diameter and have a filter with 99% or greater efficiency and a cyclonic pre-separator or filter-cleaning mechanism</p>	APF 10	APF 25
(xii) Handheld grinders for uses other than mortar removal	<p>For tasks performed outdoors only:</p> <p>Use grinder equipped with integrated water delivery system that continuously feeds water to the grinding surface</p> <p>Operate and maintain tool in accordance with manufacturer's instructions to minimize dust emissions</p> <p>OR</p> <p>Use grinder equipped with commercially available shroud and dust collection system</p> <p>Operate and maintain tool in accordance with manufacturer's instructions to minimize dust emissions</p> <p>Dust collector must provide 25 cubic feet per minute (cfm) or greater of airflow per inch of wheel diameter and have a filter with 99% or greater efficiency and a cyclonic pre-separator or filter-cleaning mechanism:</p>	None	None



## Silica Exposure Plan

Equipment/task	Engineering and work practice control methods	Required respiratory protection and minimum assigned protection factor (APF)	
		≤ 4 hours/shift	>4 hours/shift
	-When used outdoors	None	None
	-When used indoors or in an enclosed area	None	APF 10
(xiii) Walk-behind milling machines and floor grinders	Use machine equipped with integrated water delivery system that continuously feeds water to the cutting surface  Operate and maintain tool in accordance with manufacturer's instructions to minimize dust emissions	None	None
	OR Use machine equipped with dust collection system recommended by the manufacturer  Operate and maintain tool in accordance with manufacturer's instructions to minimize dust emissions  Dust collector must provide the air flow recommended by the manufacturer, or greater, and have a filter with 99% or greater efficiency and a filter-cleaning mechanism  When used indoors or in an enclosed area, use a HEPA-filtered vacuum to remove loose dust in between passes	None	None
(xiv) Small drivable milling machines (less than half-lane)	Use a machine equipped with supplemental water sprays designed to suppress dust. Water must be combined with a surfactant  Operate and maintain machine to minimize dust emissions	None	None
(xv) Large drivable milling machines (half-lane and larger)	For cuts of any depth on asphalt only: Use machine equipped with exhaust ventilation on drum enclosure and supplemental water sprays designed to suppress dust  Operate and maintain machine to minimize dust emissions	None	None
	For cuts of four inches in depth or less on any substrate:  Use machine equipped with exhaust ventilation on drum enclosure and supplemental water sprays designed to suppress dust	None	None



## Silica Exposure Plan

Equipment/task	Engineering and work practice control methods	Required respiratory protection and minimum assigned protection factor (APF)	
		≤ 4 hours/shift	>4 hours/shift
	<p>Operate and maintain machine to minimize dust emissions</p> <p>OR</p> <p>Use a machine equipped with supplemental water spray designed to suppress dust. Water must be combined with a surfactant</p> <p>Operate and maintain machine to minimize dust emissions</p>	None	None
(xvi) Crushing machines	<p>Use equipment designed to deliver water spray or mist for dust suppression at crusher and other points where dust is generated (e.g., hoppers, conveyers, sieves/sizing or vibrating components, and discharge points)</p> <p>Operate and maintain machine in accordance with manufacturer's instructions to minimize dust emissions</p> <p>Use a ventilated booth that provides fresh, climate-controlled air to the operator, or <u>remote control</u> station</p>	None	None
(xvii) Heavy equipment and utility vehicles used to abrade or fracture silica-containing materials (e.g., hoe-ramming, rock ripping) or used during demolition activities involving silica-containing materials	<p>Operate equipment from within an enclosed cab</p> <p>When employees outside of the cab are engaged in the task, apply water and/or dust suppressants as necessary to minimize dust emissions</p>	None	None
(xviii) Heavy equipment and utility vehicles for tasks such as grading and excavating but not including: Demolishing, abrading, or fracturing silica-containing materials	<p>Apply water and/or dust suppressants as necessary to minimize dust emissions</p> <p>OR</p> <p>When the equipment operator is the only employee engaged in the task, operate equipment from within an enclosed cab</p>	None	None







## SWPPP INSPECTION REPORT

Project No: \_\_\_\_\_ Inspection Date: \_\_\_\_\_  
 Location: \_\_\_\_\_ Inspected by: \_\_\_\_\_  
 Stage of Construction: \_\_\_\_\_ Company: \_\_\_\_\_

	OK	NEEDS ATTENTION	N/A*
<b>Pollutant Sources</b>			
Are there any debris piles with petroleum cans, chemical containers or other sources of possible pollution?	<input type="checkbox"/>	<input type="checkbox"/>	<input type="checkbox"/>
<b>Erosion Control</b>			
Are there any barren areas which require temporary or permanent stabilization? ( <u>seeding</u> , mulch, other?)	<input type="checkbox"/>	<input type="checkbox"/>	<input type="checkbox"/>
Are all finished cuts and fill slopes adequately stabilized?	<input type="checkbox"/>	<input type="checkbox"/>	<input type="checkbox"/>
Do any structural practices show evidence of overtopping, breaks or erosion?	<input type="checkbox"/>	<input type="checkbox"/>	<input type="checkbox"/>
Are all earthen structures seeded and <u>mulched</u> ? Is vegetation providing adequate protection?	<input type="checkbox"/>	<input type="checkbox"/>	<input type="checkbox"/>
<b>Sediment Control</b>			
Are perimeter sediment trapping measures in place and functioning properly?	<input type="checkbox"/>	<input type="checkbox"/>	<input type="checkbox"/>
Have sediment-trapping practices been installed in the proper location and before extensive grading begins?	<input type="checkbox"/>	<input type="checkbox"/>	<input type="checkbox"/>
Is sediment leaving the site and/or damaging adjacent property?	<input type="checkbox"/>	<input type="checkbox"/>	<input type="checkbox"/>
Is there mud on public roads or at intersections with public roads?	<input type="checkbox"/>	<input type="checkbox"/>	<input type="checkbox"/>
<b>Runoff Conveyance and Control</b>			
Are all on-site drainage channels and outlets adequately stabilized? ( <u>channel</u> lining, seeding, other _____, outlet stabilization _____)	<input type="checkbox"/>	<input type="checkbox"/>	<input type="checkbox"/>
Is there evidence of increased off-site erosion since the project began?	<input type="checkbox"/>	<input type="checkbox"/>	<input type="checkbox"/>
Are downstream waterways and property adequately protected from increases in storm water runoff?	<input type="checkbox"/>	<input type="checkbox"/>	<input type="checkbox"/>
<b>Maintenance</b>			
Do any seeded areas require fertilizer, <u>reseeding</u> or additional mulch?	<input type="checkbox"/>	<input type="checkbox"/>	<input type="checkbox"/>
Do any structural practices require repair or clean-out?	<input type="checkbox"/>	<input type="checkbox"/>	<input type="checkbox"/>
Have temporary structural practices that are no longer needed been removed?	<input type="checkbox"/>	<input type="checkbox"/>	<input type="checkbox"/>
<b>Other</b>			
Is any work occurring in streams? Is channel damage being minimized? Is stabilization or a temporary stream crossing needed?	<input type="checkbox"/>	<input type="checkbox"/>	<input type="checkbox"/>
Are utility trenches being backfilled and seeded properly?	<input type="checkbox"/>	<input type="checkbox"/>	<input type="checkbox"/>

\* Not Applicable





## Water Intrusion and Mold Remediation Report

Provide all information requested and fax to Company Safety, Risk Management and Contracts as soon as possible. Impacted materials must be dried within 48 hours. Notification must be made within 4 hours.

### General Information

Date of Report \_\_\_\_\_  
 Name of Person Completing Report \_\_\_\_\_  
 Project Name and Number \_\_\_\_\_  
 Project Address and Phone \_\_\_\_\_  
 Project Manager \_\_\_\_\_  
 Project Superintendent \_\_\_\_\_  
 Project Owner, Contact and Contact Number \_\_\_\_\_  
 Cost Code \_\_\_\_\_

### Investigation

Date and Time of Incident \_\_\_\_\_  
 Date First Reported \_\_\_\_\_

#### Incident Type

- Water intrusion  
 Mold remediation

#### Source of water or moisture

- Leaking plumbing  
 Sewer backup  
 Weather related (rain, snow, etc.) Describe: \_\_\_\_\_  
 \_\_\_\_\_

- Other (Describe): \_\_\_\_\_  
 \_\_\_\_\_

#### Subcontractor and/or vendor insurance information:

--

Contact Name	Company	Phone Number

To evaluate remedial options, describe all impacted areas and provide estimates of the amount of impacted material in each area.

Area	Estimated Square Feet Impacted		
	≤ 10	10 - 100	≥ 100

Area Sketch, Photos and Descriptions (Use additional sheets of paper and attach to completed package).

---



---



---



---



---

**Damage Estimate:**

\_\_\_\_\_ Less than \$1,000  
 \_\_\_\_\_ More than \$1,000

**Notification Documentation**

Owner and/or Owner's Representative

Name, Date and Time Contacted	Company	Contact Number

Tenants and/or Occupants

Name, Date and Time Contacted	Company	Contact Number

Subcontractors/Vendors

Name, Date and Time Contacted	Company	Contact Number

On a separate sheet of paper, describe events leading up to incident including dates, times, witness statements and contact information.



## WRITTEN SAFETY VIOLATION NOTIFICATION

Date: \_\_\_\_\_

Name: \_\_\_\_\_ Company: \_\_\_\_\_

Address: \_\_\_\_\_

City, State, Zip: \_\_\_\_\_

Craft: \_\_\_\_\_

Employee ID Number: \_\_\_\_\_

You were observed in the violation of \_\_\_\_\_

\_\_\_\_\_

at the \_\_\_\_\_ Project Site \_\_\_\_\_

Project No. \_\_\_\_\_ On, \_\_\_\_\_

Date

Time

<input type="checkbox"/> Class 1A Violation	<input type="checkbox"/> Class 1B Violation	<input type="checkbox"/> Class 1C Violation
<input type="checkbox"/> Class 2 Violation		
<input type="checkbox"/> This notice is a written notice only.		
<input type="checkbox"/> This notice is to inform you of a <input type="checkbox"/> three, <input type="checkbox"/> six, consecutive scheduled workdays (Company Employee suspension without pay.) (Subcontractor employee removed from Company Project Sites, see bottom line.)		
Beginning on _____	Ending on _____	
<input type="checkbox"/> This notice is to terminate your employment (Subcontractor employee removed from site) for a period of one calendar year for repeat safety violations of the Company Safety Program.		
This notice is to _____ to inform said company of the above referenced violation and request immediate action in regard to discipline as outlined in the Company Safety Protection Policy Program of the SafeRing Program.		

If you have any questions, please contact our Safety Department or Employment Resources Department at 314-733-2000.

Sincerely,

Name  
Title

Copy: Labor Relations  
Union Affiliation \_\_\_\_\_  
Safety Department  
File: Written Safety Violation Notification  
Form: 5568